

NO	DESCRIPTION OF REVISIONS	DATE	MADE BY
1	2010 EDITION	03/10	C. COLE
2	2011 EDITION - UPDATED GASKET NOTE IN FRAME DETAIL	09/11	C. COLE

NOTES:

1. See Specifications for materials and Construction.
2. Structural steel shall conform to applicable requirements of ASTM A36.
3. All welding shall conform to the requirements of the American welding society, ANSI/AASHTO/AWS D1.5-96 bridge welding code.
4. All bolts shall conform to ASTM A307. Threaded inserts shall be loop type (UNC. thread).
5. All bolts nuts and washers shall be galvanized in accordance with ASTM A153. All other steel shall be galvanized after fabrication in accordance with applicable requirements of ASTM A123.
6. Grind chamfer (1/16" +/-) on all edges of cover plate.
7. Lid shall be bonded in an approved fashion.
8. The conduits shall be secured and sealed to the blockout. All blockouts material shall be removed once concrete has cured.

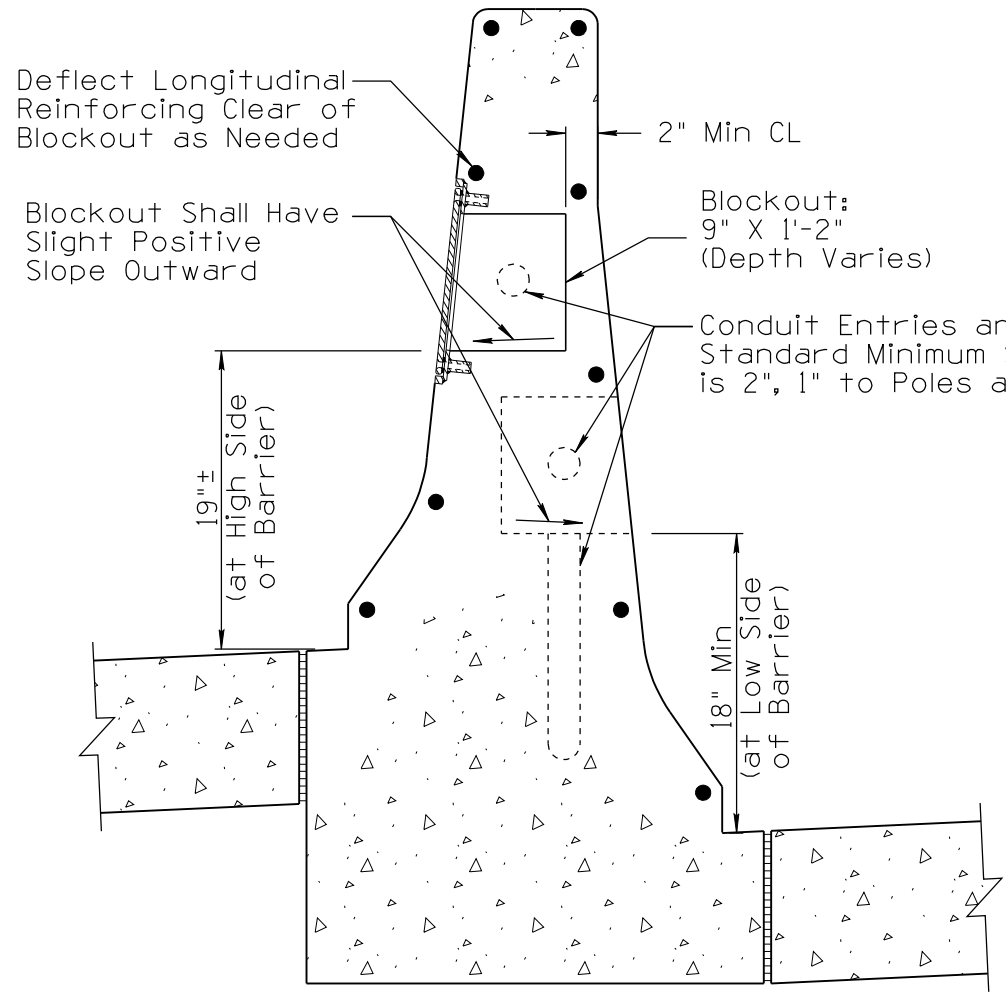

SECTION

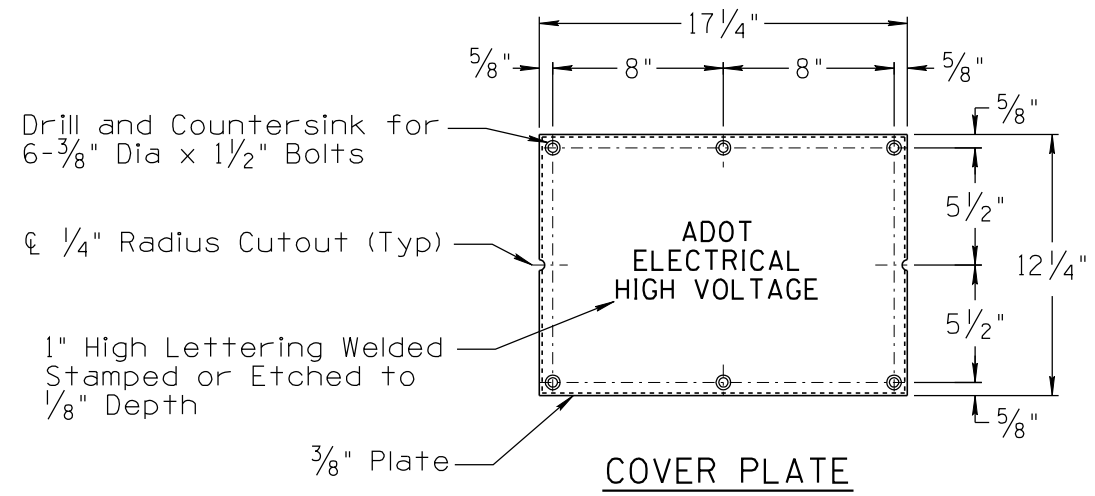

COVER PLATE

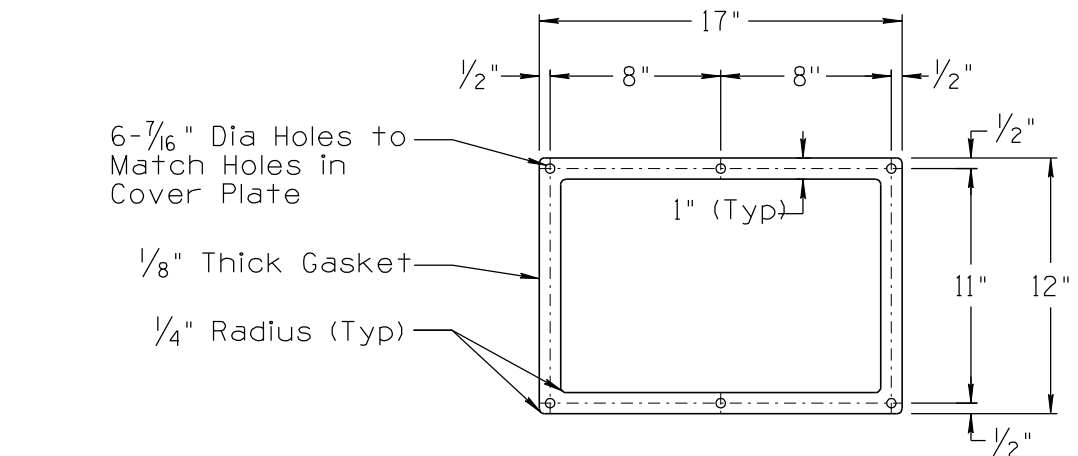

NEOPRENE GASKET

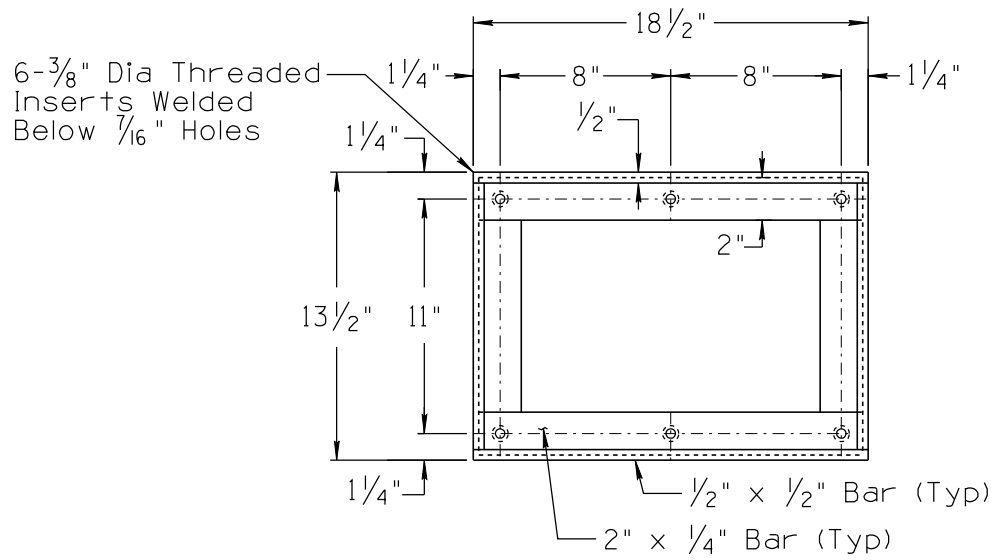

JUNCTION BOX FRAME

NOT TO SCALE

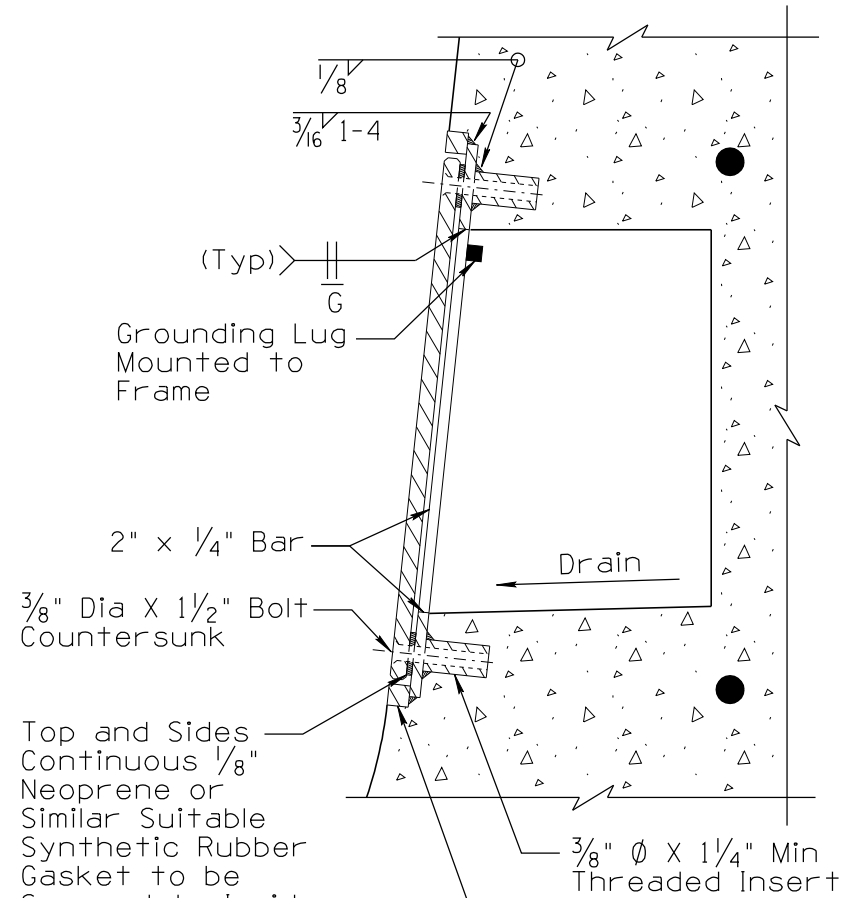

FRAME DETAIL

DESIGN APPROVED	ARIZONA DEPARTMENT OF TRANSPORTATION INTERMODAL TRANSPORTATION DIVISION TRAFFIC SIGNALS AND LIGHTING STANDARD DRAWINGS	REVISION 09/11
SIGNATURE		DRAWING NO. T.S. 1-9
APPROVED FOR DISTRIBUTION	TOP OF BARRIER JUNCTION BOX DETAILS	SHEET NO. 1 OF 1
ON FILE		