

**ARIZONA DEPARTMENT OF
TRANSPORTATION**

**ALTERNATIVE DELIVERY AND MAJOR
PROJECTS**

REQUEST FOR PROPOSALS

FOR

PROJECT NUMBER: PEV23 01X

**ARIZONA NATIONAL ELECTRIC VEHICLE
INFRASTRUCTURE DEPLOYMENT PROGRAM:
PHASE 1 – INTERSTATES**



VOLUME II: PROJECT AGREEMENT

RFP Issued January 19, 2024

Addendum 1 Issued March 8, 2024

[Addendum 2 Issued April 8, 2024](#)

TABLE OF CONTENTS

	Page
ARTICLE 1. ACRONYMS, DEFINITIONS AND INTERPRETATIONS; ORDER OF PRECEDENCE; REFERENCE INFORMATION DOCUMENTS.....	2
1.1 Acronyms, Definitions and Interpretations.....	2
1.2 Order of Precedence.....	4
1.3 Reference Information Documents.....	5
ARTICLE 2. TERM; SURVIVAL; NOTICES TO PROCEED.....	6
2.1 Term.....	6
2.2 Survival.....	6
2.3 Conditions Precedent to Effective Date.....	7
2.4 Notices to Proceed.....	8
2.5 Notice[s] to Proceed (Construction).....	8
ARTICLE 3. REPRESENTATIONS, WARRANTIES AND COVENANTS.....	9
3.1 Representations and Warranties of the Developer.....	9
3.2 Representations and Warranties of ADOT.....	11
ARTICLE 4. GENERAL REQUIREMENTS.....	12
4.1 NEVI Federal Standards and Requirements.....	12
4.2 ADOT Standards and Requirements.....	12
4.3 Project Site[s].....	12
4.4 Government Approvals; NEPA Approvals.....	14
4.5 Submittal and Oversight.....	15
4.6 Key Personnel.....	16
4.7 General Obligations.....	16
4.8 Proposed Modifications to Technical Requirements.....	17
ARTICLE 5. PROJECT SCHEDULE AND D&C PERIOD REPORTING.....	17
5.1 Project Schedule.....	17
5.2 D&C Period Reporting.....	17
5.3 Services Commencement.....	17
ARTICLE 6. REVENUE; PRICING.....	18
6.1 Revenue.....	18

TABLE OF CONTENTS
(continued)

	Page
6.2 End User Pricing.....	19
ARTICLE 7. DATA, PRIVACY AND CYBERSECURITY.....	19
7.1 Data Reporting.....	19
7.2 Data Audits.....	20
7.3 Privacy and Cybersecurity.....	20
ARTICLE 8. PAYMENTS.....	20
8.1 Services Commencement Payment.....	20
8.2 O&M Payments.....	21
8.3 Project Payment Cap.....	22
8.4 Reimbursement Principle.....	22
8.5 Limitations, Deductions and Withholdings.....	23
ARTICLE 9. NONCOMPLIANCE EVENTS AND PERFORMANCE DEDUCTIONS; QUARTERLY PERFORMANCE REPORTING DURING THE O&M PERIOD.....	23
9.1 Noncompliance Event for Failure to Report.....	23
9.2 Noncompliance Event for Failure to Adhere to the NEVI Federal Uptime Requirement.....	24
9.3 Performance Deductions Assessment Process.....	24
9.4 Remedial Plans.....	24
9.5 Acknowledgements Regarding Performance Deductions.....	24
9.6 Quarterly Performance Reporting during the O&M Period.....	25
9.7 ADOT Right to Dispute Quarterly Performance Report.....	25
ARTICLE 10. RELIEF EVENTS.....	26
10.1 Entitlement to Claim.....	26
10.2 Notice and Information.....	26
10.3 Mitigation.....	27
10.4 Failure to Provide Required Notice or Information.....	27
10.5 Grant of Relief.....	27
10.6 Sole Remedy.....	28
ARTICLE 11. INSURANCE.....	28
11.1 Insurance Policies.....	28

TABLE OF CONTENTS
(continued)

	Page
11.2 Waiver of Subrogation.....	28
11.3 Notice of Cancellation.....	28
11.4 Evidence of Coverage.....	28
11.5 Coverage Requirements.....	29
11.6 Qualified Insurers.....	29
ARTICLE 12. PERFORMANCE AND PAYMENT SECURITY.....	29
12.1 Provision of Bonds during D&C Period.....	29
12.2 Performance Security during O&M Period.....	30
12.3 Eligible Security Issuer.....	31
ARTICLE 13. INDEMNIFICATION.....	32
13.1 Indemnity by the Developer.....	32
13.2 Defense and Indemnification Procedures.....	34
13.3 Assignment of Claims to ADOT.....	36
ARTICLE 14. DEVELOPER DEFAULT.....	37
14.1 Developer Default.....	37
14.2 Notice and Cure Periods.....	38
14.3 Termination for Developer Default.....	39
14.4 Compensation on Termination.....	40
14.5 Termination for Convenience.....	41
ARTICLE 15. SUBCONTRACTING AND LABOR PRACTICES.....	42
15.1 Labor Standards.....	42
15.2 Nondiscrimination; Equal Employment Opportunity.....	42
15.3 Responsibility for Developer-Related Entities.....	43
15.4 Prevailing Wages.....	43
15.5 Prompt Payment.....	44
15.6 Suspension and Debarment Certifications.....	44
15.7 AZ UTRACS and DOORS Registration.....	45
15.8 Approval of Subcontracts.....	45
15.9 Conflict of Interests.....	45
ARTICLE 16. RECORDS, AUDIT AND PUBLIC RECORDS.....	45

TABLE OF CONTENTS
(continued)

	Page
16.1 Maintenance and Inspection of Records.....	45
16.2 Audits.....	46
16.3 Arizona Public Records Act and Freedom of Information.....	46
ARTICLE 17. CONSEQUENTIAL DAMAGES.....	47
17.1 No Consequential Damages.....	47
17.2 Exclusions.....	48
ARTICLE 18. MISCELLANEOUS PROVISIONS.....	48
18.1 Amendments.....	48
18.2 Waiver.....	48
18.3 Independent Contractor.....	49
18.4 Successors and Assigns; Change of Control.....	49
18.5 Change of Organization or Name.....	50
18.6 Designation of Representatives; Cooperation with Representatives.....	51
18.7 Limitation on Third Party Beneficiaries.....	51
18.8 No Personal Liability of ADOT Employees; Limitation on State's Liability.....	51
18.9 Governing Law; Jurisdiction.....	52
18.10 Israel Boycott and Forced Labor of Ethnic Uyghurs.....	52
18.11 Notices and Communications.....	52
18.12 Taxes.....	54
18.13 Integration of Contract Documents.....	54
18.14 Severability.....	54
18.15 Headings.....	54
18.16 Entire Agreement.....	54
18.17 Counterparts.....	54

LIST OF EXHIBITS

- Exhibit 1 Acronyms and Definitions
- Exhibit 2 Technical Requirements
- Exhibit 3 Developer’s Proposal Commitments
- Exhibit 4 Performance Deductions
- Exhibit 5 Performance Reports
- Exhibit 6 Insurance
- Exhibit 7 Form of D&C Performance Bond and D&C Payment Bond
- Exhibit 8 Form of ADOT License
- Exhibit 9 Federal and State Requirements
- Exhibit 10 Project Site
- Exhibit 11 Authorized Representatives

**PUBLIC PRIVATE PARTNERSHIP PROJECT AGREEMENT
ARIZONA NEVI DEPLOYMENT PROGRAM: PHASE 1 - INTERSTATES**

This Project Agreement (this “**Agreement**”) is entered into and effective as of [EFFECTIVE DATE], by and between the Arizona Department of Transportation, a public agency of the State of Arizona (“**ADOT**”), and [REDACTED], a [REDACTED] (together with its permitted successors and assigns, “**Developer**”). “**ADOT**” and “**Developer**” are referred to individually herein as “**Party**” and, collectively, as “**Parties**.”¹

RECITALS

- (A) The Infrastructure Investment and Jobs Act, enacted November 15, 2021, includes a National Electric Vehicle Infrastructure Formula Program (the “**NEVI Formula Program**”) to provide dedicated funding to strategically deploy electric vehicle charging infrastructure. The State of Arizona Electric Vehicle Infrastructure Deployment Plan (the “**Plan**”) sets forth the State’s approach to utilizing its apportionment of the NEVI Formula Program.
- (B) To facilitate performance of the Plan, ADOT wishes to procure from the Developer the design, construction, financing, testing, commissioning, provisioning, operation, and maintenance of the electric vehicle charging station, including all electric vehicle supply equipment (“**EVSE**”), located at [each][the]² project site set forth in Exhibit 10 (*Project Site/s*) ([each, a] “**Project Site**”) as further described in this Agreement (collectively, the “**Project**”).
- (C) ADOT procured this Agreement pursuant to Arizona Revised Statutes (“**A.R.S.**”) §§ 28-7701 – 28-7711 (the “**P3 Law**”), which authorizes ADOT to develop public-private partnership projects using a variety of delivery methods.
- (D) Pursuant to the P3 Law and ADOT’s P3 Program Guidelines as authorized by A.R.S. Title 28, Chapter 22, § 7702 (the “**Guidelines**”), ADOT issued a Request for Proposals on January 19, 2024 (as amended, the “**RFP**”) for the Project.
- (E) As part of the RFP, ADOT required that Proposers commit to entering into this Agreement to design, build, finance, operate and maintain the Project.
- (F) In response to the RFP, ADOT received [insert number] proposals for NEVI Zone [Insert Number].³

¹ **NOTE TO PROPOSERS:** If the Developer’s financial plan included the provision of a guarantor, the Project Agreement will be supplemented to include necessary guarantor deliverables and related events of default.

² **NOTE TO PROPOSERS:** Certain language is shown in the alternative in brackets throughout the Project Agreement in order to accommodate single or multiple Charging Stations being delivered under a single Project Agreement.

³ **NOTE TO PROPOSERS:** If multiple Charging Stations are governed by the Project Agreement, this recital will be revised to reference each NEVI Zone.

- (G) After conducting a thorough analysis of all responses to the RFP, ADOT determined that Developer’s proposal for NEVI Zone **[Insert Number]**⁴ best met the selection criteria contained in the RFP and that the proposal was the one that provided the best value to the State and recommended that a project agreement be awarded to the Developer for NEVI Zone **[Insert Number]**⁵.

NOW, THEREFORE, in consideration of the premises and of the terms, conditions, covenants, and other requirements contained hereof and made a part herein, including the appendices attached hereto, it is hereby agreed by and between the Parties as follows:

**ARTICLE 1.
ACRONYMS, DEFINITIONS AND INTERPRETATIONS; ORDER OF PRECEDENCE;
REFERENCE INFORMATION DOCUMENTS**

1.1 Acronyms, Definitions and Interpretations.

1.1.1 Unless the context otherwise requires, in this Agreement:

(a) capitalized terms and acronyms have the meanings given in Exhibit 1 (Acronyms and Definitions);

(b) the words “including,” “includes” and “include” will be read as if followed by the words “without limitation;”

(c) the meaning of “or” will be that of the inclusive “or,” that is meaning one, some or all of a number of possibilities;

(d) a reference to any Party or Person includes each of their legal representatives, trustees, executors, administrators, successors, and permitted substitutes and assigns, including any Person taking part by way of novation;

(e) references to days are references to calendar days, provided that, if the date to perform any act or provide any Notice falls on a non-Business Day, such act or Notice may be timely performed on the next Business Day. Notwithstanding the foregoing, requirements contained in this Agreement relating to actions to be taken in the event of an emergency and other requirements for which it is clear that performance is intended to occur on a non-Business Day shall be required to be performed as specified, even though the date in question may fall on a non-Business Day;

⁴ **NOTE TO PROPOSERS:** If multiple Charging Stations are governed by the Project Agreement, this recital will be revised to reference each NEVI Zone.

⁵ **NOTE TO PROPOSERS:** If multiple Charging Stations are governed by the Project Agreement, this recital will be revised to reference each NEVI Zone.

(f) a reference to any Governmental Entity, institute, association or body is:

(i) if that Governmental Entity, institute, association or body is reconstituted, renamed or replaced or if the powers or functions of that Government Entity, institute, association or body are transferred to another organization, a reference to the reconstituted, renamed or replaced organization or the organization to which the powers or functions are transferred, as applicable; and

(ii) if that Governmental Entity, institute, association or body ceases to exist, a reference to the organization that serves substantially the same purposes or objectives as that Governmental Entity, institute, association or body;

(g) a reference to this Agreement or to any other agreement, document or instrument includes a reference to this Agreement or such other agreement, document or instrument as amended, revised, supplemented or otherwise modified from time to time;

(h) a reference to any legislation or to any section or provision of it includes any amendment to or re-enactment of, or any statutory provision substituted for, that legislation, section or provision;

(i) words in the singular include the plural (and vice versa) and words denoting any gender include all genders;

(j) headings are for convenience only and do not affect the interpretation of this Agreement;

(k) a reference to a Section, Appendix, or Exhibit is a reference to a Section, Appendix, or Exhibit of or to the document in which the reference appears;

(l) where any word or phrase is given a defined meaning, any other part of speech or other grammatical form of that word or phrase has a corresponding meaning;

(m) a reference to "\$" or to any other monetary amount is to currency in the United States;

(n) a reference to time is a reference to Mountain Standard Time in the United States as observed in the State, which does not follow daylight savings time;

(o) Submittals received by ADOT after 5:00 p.m. shall be deemed to have been received the next Business Day;

(p) in the event of an ambiguity in or dispute regarding the interpretation of this Agreement, this Agreement shall not be interpreted or construed

against the Person who prepared this Agreement, and, instead, other rules of interpretation and construction shall be used;

(q) the term “may,” when used in the context of a power or right exercisable by ADOT or ADOT’s Authorized Representative, means that ADOT or ADOT’s Authorized Representative can exercise that right or power in its discretion and ADOT or ADOT’s Authorized Representative has no obligation to the Developer to do so;

(r) an obligation to do something “promptly” means an obligation to do so as soon as the circumstances permit, avoiding any delay;

(s) in the computation of periods of time from a specified date to a later specified date, the word “from” means “from and including” and the words “to” and “until” mean “to and including”;

(t) unless otherwise noted, “discretion” means sole, absolute and unfettered discretion; and

(u) “reasonable” means just, rational, appropriate, ordinary, or usual under the circumstances.

1.2 Order of Precedence.

1.2.1 Unless the context otherwise requires and except as provided otherwise in this Section 1.2 (Order of Precedence), in the event of any conflict, ambiguity or inconsistency between or among the Contract Documents, the order of precedence, from highest to lowest, is as follows:

(a) The provisions of the main body of this Agreement, as may be amended from time to time;

(b) The provisions of Exhibit 2 (Technical Requirements), Part A (NEVI Federal Standards and Requirements);

(c) The provisions of the exhibits to this Agreement, other than Exhibit 2 (Technical Requirements) and Exhibit 3 (Developer’s Proposal Commitments);

(d) The provisions of Exhibit 2 (Technical Requirements), Part B (ADOT Standards and Requirements); and

(e) The provisions of Exhibit 3 (Developer’s Proposal Commitments).

In each case, as amended or supplemented from time to time in accordance with this Agreement.

1.2.2 If there is a conflict, ambiguity, or inconsistency between (a) any of the provisions of this Agreement and the NEVI Federal Standards and Requirements, the NEVI Federal Standards and Requirements will prevail, or (b) any of the provisions of this Agreement having the same order of precedence, the provisions establishing a higher standard of safety, reliability, quality level of service, quantity or scope will prevail.

1.2.3 Additional or supplemental details or requirements in a lower priority Contract Document shall be given effect except to the extent they irreconcilably conflict with requirements, provisions and practices contained in the higher priority Contract Document.

1.2.4 Developer acknowledges and agrees that it had the opportunity and obligation, before submission of its proposal, to review the terms and conditions of this Agreement and to bring to the attention of ADOT any conflicts, ambiguities or inconsistencies of which it is aware contained within this Agreement.

1.2.5 ADOT's interim or final answers to the questions posed during the RFP process for this Agreement do not form part of this Agreement and are not relevant in interpreting this Agreement, except to the extent ADOT, in its discretion, believes this Agreement is ambiguous, in which case such interim or final answers may be used to clarify such ambiguous provisions.

1.2.6 Incorporation into this Agreement of any part of the Developer's proposal, including Exhibit 3 (Developer's Proposal Commitments) shall not (a) limit, modify, or alter ADOT's right to review and approve any Submittal required hereunder, or (b) be deemed as acceptance or approval of any part of the Developer's proposal by ADOT.

1.2.7 Developer shall not take advantage of or benefit from any apparent or actual error, conflict, ambiguity or inconsistency in this Agreement. If Developer becomes aware that any matters with respect to the Work are not sufficiently detailed, described, or explained in this Agreement, or if Developer becomes aware of any error or any conflict, ambiguity or inconsistency between or among the documents forming this Agreement, Developer shall promptly provide Notice to ADOT, including the item Developer considers should apply based on the applicable rules in this Section 1.2 (Order of Precedence). Except as expressly stated in this Agreement, if (a) the error, conflict, ambiguity or inconsistency cannot be reconciled by applying the applicable rules or (b) the Parties disagree about (i) which rule applies or (ii) the results of the application of such applicable rule(s), then ADOT will determine, in its reasonable discretion, which of the conflicting items is to apply and provide Notice to the Developer before the Developer proceeds with the applicable aspect of the Work.

1.3 Reference Information Documents.

1.3.1 Developer acknowledges and agrees that neither ADOT nor any ADOT Person gives any warranty, representation or undertaking in respect of the

Reference Information Documents, including that the Reference Information Documents:

- (a) are complete, accurate or fit for purpose;
- (b) contain accurate or reliable cost estimates; or
- (c) represent all of the information in ADOT's possession or power, relevant or material in connection with the Project.

1.3.2 Developer acknowledges and agrees that:

- (a) it has, before the Effective Date, conducted its own analysis and review of the Reference Information Documents upon which it places reliance;
- (b) any use or reliance on such Reference Information Documents by the Developer shall be solely at its own risk; and
- (c) ADOT will not have any liability to the Developer in respect of Reference Information Documents.

ARTICLE 2. TERM; SURVIVAL; NOTICES TO PROCEED

2.1 Term. This Agreement shall take effect on the Effective Date and shall remain in effect until the earlier to occur of (a) the Expiry Date, and (b) Early Termination [with respect to all Project Sites] (the "**Term**").

2.2 Survival. Notwithstanding any other provision of this Agreement, any provisions of this Agreement together with any provisions necessary to give effect to such provisions that expressly or by implication from their nature are intended to survive the Term shall survive the Term, including the following provisions:

2.2.1 any obligation of the Developer to perform decommissioning work under Section 4.3.2 (Project Site Expiry Date Obligations);

2.2.2 any ongoing reporting, privacy and cybersecurity obligations under ARTICLE 7 (Data, Privacy and Cybersecurity);

2.2.3 ARTICLE 11 (Insurance);

2.2.4 any ADOT right to claim the Performance Security under ARTICLE 12 (Performance and Payment Security);

2.2.5 ARTICLE 13 (Indemnification);

2.2.6 any obligations of the Developer to pay compensation under Section 14.4 (Compensation on Termination);

2.2.7 ARTICLE 16 (Records, Audit and Open Records);

2.2.8 ARTICLE 17 (Consequential Damages);

2.2.9 ARTICLE 18 (Miscellaneous Provisions); and

2.2.10 all other provisions that by their inherent character should survive the Expiry Date or Early Termination of, or completion of the Work under, this Agreement.

2.3 Conditions Precedent to Effective Date. The occurrence of the Effective Date is subject to the satisfaction (or waiver by the Party benefiting) of each of the following conditions on or prior to the date of this Agreement (“**Effective Date Conditions Precedent**”):

2.3.1 **Effective Date Documents.** The Developer has delivered to ADOT each of the following documents executed by the relevant parties (other than ADOT where ADOT is a party):

- (a) this Agreement;
- (b) the ADOT License [for each Project Site];
- (c) the D&C Performance Bond and the D&C Payment Bond [covering all Project Sites]; and
- (d) For each Project Site not owned by the Developer (if any), the Host Site Agreement, incorporating all HSA Key Terms.

2.3.2 **Corporate Documents.** The Developer has delivered to ADOT documents and certificates evidencing:

- (a) the organization, existence, and good standing of the Developer; and
- (b) the authorization of the entry by the Developer into this Agreement and each of the other documents set forth in Section 2.3.1 (Effective Date Documents).

2.3.3 **Qualification to do Business.** The Developer has provided to ADOT evidence reasonably acceptable to ADOT that the Developer is qualified to do

business in Arizona [and that Developer complies with the requirements of A.R.S. Title 10, Chapter 38]⁶.

2.3.4 **Licensing Requirements.** The Developer has provided evidence reasonably acceptable to ADOT that the Developer and the Subcontractors have obtained all licenses, including the licenses described in A.R.S. Title 32, Chapters 1 and 10, that are required as of the Effective Date under applicable Law in order to undertake the Work and carry out the Developer's obligations under this Agreement following the Effective Date.

2.3.5 **Certificates and Affidavits.** The Developer has delivered to ADOT each of the certificates and affidavits required to be signed by the Developer, as set out in Exhibit 9 (Federal and State Requirements).

2.3.6 **Insurance.** The Developer has provided to ADOT evidence that it has obtained the Developer Required Insurance, in the form of an updated ACORD certificate of insurance.

2.3.7 **ADOT Documents.** ADOT has executed and delivered to the Developer this Agreement and the ADOT License [for each Project Site].

2.3.8 **Project Schedule.** The Developer has submitted the Project Schedule to be incorporated in Exhibit 3 (Developer's Proposal Commitments), Part B (Project Schedule). The Project Schedule shall reflect the Proposal Schedule, with updates limited to the incorporation of the confirmed Effective Date and corresponding updates to each milestone (but without amending the timeframes between each milestone, which shall remain consistent with the Proposal Schedule).

2.4 Notices to Proceed.

2.4.1 Notice to Proceed (Design and Materials).

(a) ADOT anticipates issuing a notice to commence Design Work [for all of the Project Sites] ("**NTP (Design and Materials)**") promptly following the Effective Date and will in any case issue NTP (Design and Materials) within three Business Days after the Effective Date.

(b) Issuance of NTP (Design and Materials) authorizes the Developer to:

- (i) commence Design Work;
- (ii) commence any preliminary site survey work;

⁶ **NOTE TO PROPOSERS:** Bracketed language to be added if Developer is a foreign entity.

- (iii) commence acquisition of materials for the D&C Work;
- (iv) engage in the other activities under the Contract Documents that are authorized to be performed after NTP (Design and Materials); and
- (v) satisfy the conditions to issuance of the notice to commence the Construction Work [for each Project Site] ("**NTP (Construction)**") under Section 2.5 (Notice to Proceed (Construction)).

2.5 Notice[s] to Proceed (Construction).

(a) Upon satisfaction of the conditions precedent set out in Section 2(a) (Project Management, Reporting, and Submittals) of the ADOT Standards and Requirements [for a Project Site] ("**NTP (Construction) Conditions Precedent**"), ADOT will issue an NTP (Construction) [for such Project Site] to the Developer.

(b) [ADOT may issue one NTP (Construction) for multiple Project Sites.] Issuance of NTP (Construction) authorizes and requires the Developer to commence the Construction Work [for each Project Site described in the NTP (Construction)], subject to complying with all relevant provisions of this Agreement.

(c) The Developer shall not commence or permit commencement of the Construction Work [for a Project Site] unless ADOT has issued an NTP (Construction) [for such Project Site] to the Developer.

ARTICLE 3. REPRESENTATIONS, WARRANTIES AND COVENANTS

3.1 Representations and Warranties of the Developer. The Developer represents, warrants and covenants to ADOT that:

3.1.1 the Developer and its Subcontractors and their respective employees have all required authority, licenses, registrations, professional ability, skills and capacity to perform the Work in accordance with the requirements contained in the Contract Documents, including the licenses required under A.R.S. Title 32, Chapters 1 and 10;

3.1.2 based upon the Developer's reasonable investigation, the Developer has evaluated the constraints affecting design, construction, operation and maintenance of the Project, and is satisfied that it is feasible to design, develop, operate and maintain the Project within such constraints;

3.1.3 the Developer has evaluated the feasibility of satisfying the conditions to Services Commencement [for each Project Site] by the [applicable] Services Commencement Deadline, accounting for constraints affecting the Project, and is satisfied that such performance is feasible and practicable;

3.1.4 the Developer has evaluated the feasibility of performing the O&M Work [for each Project Site] throughout the O&M Period [for such Project Site] and is satisfied that such performance is feasible and practicable;

3.1.5 the Developer has familiarized itself with the requirements of all applicable Laws (including the NEVI Federal Standards and Requirements) and the conditions of any required Governmental Approvals and NEPA Approvals. As of the Effective Date, Developer has no reason to believe that any Governmental Approvals required to be obtained by the Developer will not be granted in due course and thereafter remain in effect to enable the Work to proceed in accordance with the Contract Documents;

3.1.6 the Developer is in compliance with all federal immigration laws and regulations and A.R.S. § 23-214, subsection A that relate to its employees and the employees of the Subcontractors. The Developer agrees, warrants and acknowledges that a breach of this warranty shall be deemed a material breach of the Agreement that is subject to penalties, and ADOT may terminate this Agreement. ADOT retains the legal right to inspect the documentation of the Developer's employees and of any Subcontractor employee who works on the Project to ensure that Developer or Subcontractor is complying with this warranty;

3.1.7 all Work furnished by the Developer will be performed by or under the supervision of Persons who hold all necessary and valid licenses to perform the Work in the State, by personnel who are careful, skilled, experienced and competent in their respective trades or professions, who are professionally qualified to perform the Work in accordance with the Contract Documents and who shall assume professional responsibility for the accuracy and completeness of the Design Documents and other documents prepared or checked by them;

3.1.8 as of the Effective Date, the Developer is a [INSERT LEGAL ENTITY] duly formed and validly existing under the laws of the state of [INSERT STATE OF FORMATION] with all requisite power and all required licenses to carry on its present and proposed obligations under the Contract Documents and has full power, right and authority to execute and deliver the Contract Documents and the Subcontracts to which the Developer is (or will be) a party, and to perform each and all of the obligations of the Developer provided for herein and therein;

3.1.9 the Developer is duly qualified to do business, and is in good standing in the State as of the Effective Date, and will remain in good standing throughout the Term and for as long thereafter as any obligations remain outstanding under the Contract Documents;

3.1.10 the execution, delivery and performance of the Contract Documents and the Subcontracts to which Developer is (or will be) a party have been (or will be) duly authorized by all necessary [INSERT LEGAL ENTITY] action of the Developer; each person executing the Contract Documents and the Subcontracts on behalf of the Developer has been (or at the time of execution will be) duly authorized to

execute and deliver each such document on behalf of the Developer; and the Contract Documents and the Subcontracts have been (or will be) duly executed and delivered by the Developer;

3.1.11 neither the execution and delivery by the Developer of the Contract Documents or the Subcontracts to which Developer is (or will be) a party, nor the consummation of the transactions contemplated hereby or thereby, is (or at the time of execution will be) in conflict with or has resulted or will result in a default under or a violation of the governing instruments or organizational documents of the Developer or a breach or default under any credit agreement or other material agreement or instrument to which the Developer is a party or by which its properties and assets may be bound or affected;

3.1.12 each of the Contract Documents and the Subcontracts to which the Developer is (or will be) a party constitutes (or at the time of execution and delivery will constitute) the legal, valid and binding obligation of the Developer, enforceable against the Developer, in accordance with its terms, subject only to applicable bankruptcy, insolvency and similar laws affecting the enforceability of the rights of creditors generally and to general principles of equity;

3.1.13 as of the Effective Date, there is no action, suit, proceeding, investigation or litigation pending or, to the Developer's knowledge, threatened, against the Developer that challenges the Developer's authority to execute, deliver or perform, or the validity or enforceability of, the Contract Documents or the Subcontracts to which the Developer is a party, or that challenges the authority of any of the Developer's officials that are executing the Contract Documents or the Subcontracts, and the Developer has disclosed to ADOT prior to the Effective Date any pending, unserved or threatened action, suit, proceeding, investigation or litigation with respect to such matters of which the Developer is aware; and

3.1.14 as of the Proposal Due Date, the Developer disclosed to ADOT in writing all organizational conflicts of interest of the Developer and its Subcontractors of which the Developer was actually aware; and between the Proposal Due Date and the Effective Date, the Developer has not obtained knowledge of any additional organizational conflict of interest, and there have been no organizational changes to the Developer or its Subcontractors identified in its Proposal that have not been approved in writing by ADOT. For this purpose, organizational conflict of interest has the meaning set forth in the RFP.

3.2 Representations and Warranties of ADOT. ADOT represents and warrants to the Developer that:

3.2.1 ADOT has full power, right and authority to execute, deliver and perform its obligations under, in accordance with and subject to the terms and conditions of the Contract Documents to which it is a Party; and

3.2.2 each Person executing on behalf of ADOT the Contract Documents to which ADOT is a Party has been or at the time of execution will be duly authorized to execute each such document on behalf of ADOT.

ARTICLE 4. GENERAL REQUIREMENTS

4.1 NEVI Federal Standards and Requirements.

4.1.1 Subject to Section 4.1.2, the Developer shall design, construct, finance, test, commission, provision, operate, and maintain the Project in accordance with the NEVI Federal Standards and Requirements.

4.1.2 The Developer acknowledges and agrees that any Federal Highway Administration (“**FHWA**”) guidance in respect of the NEVI Federal Standards and Requirements, and any form of decision, determination, interpretation or administration made by FHWA in respect of the NEVI Federal Standards and Requirements will be applicable to the Project.

4.2 ADOT Standards and Requirements. The Developer shall design, construct, finance, operate, and maintain the Project in accordance with the ADOT Standards and Requirements.

4.3 Project Site[s].

4.3.1 Property Interest.

(a) The Developer shall maintain sufficient title or interest, as applicable, in the Project Site[s] necessary to carry out the Work for the Term.

(b) The Developer shall ensure that the ADOT Licenses for the Project Site[s] remain[s] in effect for the duration of the Term.

(c) [The Developer shall:⁷

(i) ensure that the Host Site Agreement[s] for any Project Site[s] not owned by the Developer remain[s] in effect for the duration of the Term; and

(ii) comply with its obligations and enforce its rights under the provisions of each Host Site Agreement to the extent necessary to enable the Developer to comply with its obligations under this Agreement.

⁷ **NOTE TO PROPOSERS:** Host Site Agreement provisions under this provision will be included only if any Project Site is not owned by the Developer.

(d) The Developer shall not:

(i) assign, transfer, pledge, mortgage or otherwise encumber any of its rights or obligations under any Host Site Agreement, unless ADOT has agreed to corresponding assignment, transfer, pledge, mortgage or encumbrance of the Developer's rights and obligations under this Agreement to the same assignee in accordance with Section 18.4.2 (Successors and Assigns; Change of Control); or

(ii) enter into any amendment, supplement, waiver or other modification of any Host Site Agreement that would have a material adverse effect on the ability of the Developer to perform its obligations under this Agreement, without ADOT's prior written consent.]

4.3.2 Project Site Expiry Date Obligations.

(a) Six months prior to the end of the O&M Period [applicable to each Project Site], the Developer shall elect by written notice to ADOT:

(i) to continue operating the Project Site, or sell or transfer ownership of the Project Site to a replacement developer for ongoing operation, following the end of the [applicable] O&M Period, without any ongoing payment from ADOT ("**Expiration Option A**"); or

(ii) to cease operating the Project Site at the end of the [applicable] O&M Period and decommission the Project Site consistent with Section 4.3.2(b) ("**Expiration Option B**").

(b) If the Developer's election under Section 4.3.2 (Project Site Expiry Date Obligations) is:

(i) Expiration Option A, then the Developer shall (i) demonstrate to ADOT's reasonable satisfaction its plan to continue operations on the Project Site, [including, if applicable, evidence that it has an agreement with the Host Site Owner necessary to continue operations at the Project Site following end of the Term,]⁸ or (ii) provide evidence of an agreement to sell or transfer ownership to a replacement developer with a commitment for ongoing operations; or

(ii) Expiration Option B, then within 30 days of the end of the O&M Period of the [applicable] Project Site, the Developer must perform all decommissioning activities in accordance with Section 13(b) (Decommissioning Activities) of the ADOT Standards and Requirements [and as required by the HSA Key Terms] following the end of the Term.

⁸ **NOTE TO PROPOSERS:** This language will be included only if any Project Site is not owned by the Developer.

(c) If the Developer has not completed the decommissioning activities at the Project Site in accordance with Section 4.3.2(b)(ii), ADOT will have the right to call or draw on the O&M Performance Security for the amount of ADOT's reasonable estimate of the cost for ADOT to ensure that the decommissioning activities at the Project Site are completed.

(d) Subject to any requirements under applicable Law, ADOT will not have any ownership interest in the EVSE and other Project Site assets following the end of the Term.

4.4 Government Approvals; NEPA Approvals.

4.4.1 Compliance with Governmental Approvals. The Developer shall perform its obligations under this Agreement in compliance with all Governmental Approvals.

4.4.2 Responsibility for Governmental Approvals. The Developer is solely responsible for obtaining all Governmental Approvals (including any application, revision, modification, amendment, supplement, renewal, or extension) required in connection with its performance of this Agreement.

4.4.3 Cooperation with Respect to Governmental Approvals.

(a) If requested by the Developer, ADOT will reasonably cooperate with the Developer in relation to any application by the Developer for a Governmental Approval and will, at the reasonable request of the Developer, and where necessary to obtain, revise, modify, amend, supplement, or renew any Governmental Approval:

(i) execute any documents that can only be executed by ADOT;

(ii) make any applications as required by applicable Law, either in its own name or jointly with the Developer, that can only be made by ADOT or in joint names of the Developer and ADOT, as applicable; and

(iii) attend meetings with appropriately qualified staff and cooperate with relevant Governmental Entities as reasonably requested by the Developer,

in each case, within a reasonable period of time of being requested to do so by the Developer.

(b) If ADOT provides any assistance to the Developer pursuant to Section 4.4.3(a) (Cooperation with Respect to Governmental Approvals), the Developer shall reimburse ADOT for its reasonable third-party costs associated with the

provision of such assistance no later than 30 days after receiving an invoice from ADOT with respect to such costs.

4.4.4 Copies of Governmental Approvals. The Developer shall promptly (and in any event within five Business Days after obtaining a Governmental Approval) deliver to ADOT a true and complete copy of any new or amended Governmental Approval obtained by the Developer.

4.4.5 NEPA Approval[s].

(a) The Developer shall:

(i) perform the Work in accordance with the permissible activities identified by [the][each] NEPA Approval; and

(ii) avoid all nonpermissible ground disturbance or construction activities identified by the NEPA Approval in the performance of the Work.

(b) The Developer acknowledges that:

(i) nonpermissible ground disturbance or construction activities in a Project Site may require re-evaluation of the NEPA Approval for such Project Site, involving detailed analysis based on the ADOT NEPA re-evaluation procedure, including, but not limited to, additional environmental field studies and technical reporting; and

(ii) any such re-evaluation of a NEPA Approval is reserved for special circumstances where the Developer's avoidance of the nonpermissible activity is not possible.

(c) ADOT may elect, in its discretion, to conduct a re-evaluation of a NEPA Approval in accordance with Section 4.4.5(b)(ii) (NEPA Approval). The Developer shall comply with all directions from ADOT regarding the re-evaluation process, which may include additional state or federal agency consultation and environmental permitting processes. The Developer shall be responsible for preparing all required documentation at ADOT's direction, and all costs associated with NEPA re-evaluation. ADOT will have ultimate responsibility for finalizing the required documents and obtaining any re-evaluation. In the event that ADOT is unable to obtain any re-evaluation of a NEPA Approval for any nonpermissible ground disturbance or construction activities, the Developer shall design and construct the applicable Project Site in compliance with the requirements of the NEPA Approval applicable without the re-evaluation.

4.5 Submittal and Oversight.

4.5.1 Except as expressly set out elsewhere in this Agreement, whenever ADOT is entitled to review and comment or approve a Submittal, ADOT will

promptly respond or act upon such Submittal no later than 30 days after the date it receives from the Developer an accurate and complete Submittal, and all necessary information and documentation concerning the subject matter.

4.5.2 Subject to Section 2.4 (Notices to Proceed), the Developer may proceed with the Work at its election and risk pending review and comment or approval by ADOT of a Submittal.

4.6 Key Personnel.

4.6.1 Each individual fulfilling a Key Personnel position shall fulfill the “Role” and satisfy or exceed the “Minimum Qualifications” of such Key Personnel position listed in the Key Personnel Requirements.

4.6.2 The Developer shall ensure, and cause any Subcontractor employing Key Personnel to ensure, that each individual filling a Key Personnel position has the authority to fulfill the applicable “Role” identified in the Key Personnel Requirements.

4.6.3 The Developer shall promptly:

(a) notify ADOT if any of the individuals fulfilling a Key Personnel position are no longer able to fulfill the applicable Key Personnel Requirements;

(b) fill any vacancy in Key Personnel; and

(c) submit to ADOT the name and qualifications of any individual that Developer proposes to fulfill a Key Personnel position.

4.6.4 The Developer may place an individual in a Key Personnel position only after (a) the Developer has fulfilled the requirements in Section 4.6.3(c) with respect to such individual; and (b) ADOT has provided the Developer with written approval thereof.

4.7 General Obligations.

4.7.1 The Developer shall perform all Work in accordance with:

(a) Good Industry Practice;

(b) applicable Law, including the NEVI Federal Standards and Requirements;

(c) the requirements of all Governmental Approvals and NEPA Approval[s];

- (d) the Developer Commitments; and
- (e) the Technical Requirements and all other requirements of this Agreement.

4.7.2 The Developer, through appropriately qualified and licensed professionals, shall prepare all designs, plans and specifications in accordance with this Agreement.

4.7.3 The Developer shall perform O&M Work [for each Project Site] in a manner that ensures ongoing compliance with the O&M Performance Requirements.

4.8 Proposed Modifications to Technical Requirements. This Agreement includes Technical Requirements that are compliant with the NEVI Federal Standards and Requirements. The Developer may only deviate from the Technical Requirements with the prior written consent of ADOT in its discretion.

ARTICLE 5. PROJECT SCHEDULE AND D&C PERIOD REPORTING

5.1 Project Schedule. The Developer hereby commits to develop the Project in accordance with the milestones and time periods set out in this Agreement, including the Technical Requirements and the Project Schedule, subject only to any rights to extensions of time under ARTICLE 10 (Relief Events).

5.2 D&C Period Reporting

5.2.1 For each month during the D&C Period, the Developer shall submit a D&C Period Progress Report to ADOT.

5.2.2 The Developer shall submit to ADOT a final D&C Period Progress Report on the Services Commencement Date.

5.3 Services Commencement.

5.3.1 The Developer shall provide ADOT with not less than 30 days' prior notice of the date the Developer determines it will achieve Services Commencement [for each Project Site]. During such period, the Developer and ADOT will meet and confer and exchange information on a regular cooperative basis (no less frequently than weekly) with the goal being ADOT's orderly, timely inspection and review of the Project, and ADOT's issuance of a written certificate of Services Commencement [for the applicable Project Site] ([each, a] "**Services Commencement Certificate**").

5.3.2 ADOT will issue [each][the] Services Commencement Certificate at such time as the following conditions have been satisfied or waived by ADOT in its

discretion (the “**Services Commencement Conditions**”) with respect to the [applicable] Project Site:

(a) the D&C Work is completed in accordance with Section 4.7 (General Obligations);

(b) all EVSE are installed, functional, operational, and compliant with the requirements of the Agreement and applicable Law, including the NEVI Federal Standards and Requirements;

(c) all EVSE has passed all inspections and tests required under the Agreement and applicable Law (including the NEVI Federal Standards and Requirements), including in accordance with Section 11(a) (Equipment Certification and Testing Requirements) of the ADOT Standards and Requirements;

(d) all commitments related to the Work as required pursuant to all Governmental Approvals and NEPA Approval[s] have been completed in accordance with the Governmental Approvals and NEPA Approval[s] and this Agreement;

(e) the [applicable portion of the] Project can be used for its intended purpose;

(f) the Developer has replaced any disturbed pavement, hardscape, landscape per associated Project Site Layout or restored it to its original condition;

(g) the Developer has submitted, and ADOT has accepted, the draft Cybersecurity Plan and updates thereto;

(h) the Developer has submitted to ADOT, and ADOT has accepted, all Submittals (including all reports, data and documentation relating to any tests) required by this Agreement to be submitted to ADOT prior to Services Commencement, including the Submittals under Section 2(b) (Project Management, Reporting, and Submittals) of the ADOT Standards and Requirements;

(i) the Developer has delivered the O&M Performance Security in accordance with Section 12.2 (Performance Security during O&M Period);

(j) the Developer has presubmitted into EV-ChART the One-Time Data Submittal in accordance with Section 7.1.1(a) (Data Reporting); and

(k) the Developer has made available an Application Programming Interface (“**API**”) meeting the requirements of Section 7.1.2 (Data Reporting).

ARTICLE 6. REVENUE; PRICING

6.1 Revenue. All revenue generated at the Project Site[s] in the performance of the O&M Work shall be retained by the Developer consistent with the NEVI Federal Standards and Requirements. Revenue may be used only for the purposes listed in Section 1(m) (Use of Program Income) of the NEVI Federal Standards and Requirements. The Developer shall make available to ADOT sufficient information to evaluate and confirm that the Developer has used the Project revenue in accordance with the NEVI Federal Standards and Requirements. Any material decreases in costs or increases in revenues during the O&M Period must be reported to ADOT for review and confirmation that the Project remains in compliance with the NEVI Federal Standards and Requirements.

6.2 End User Pricing.

6.2.1 The Developer shall set end user pricing for use of the EVSE, subject to applicable Law (including the NEVI Federal Standards and Requirements).

6.2.2 In consideration for the financial assistance provided by ADOT hereunder, the Developer covenants that the price charged to end users for EV charging shall be reasonable. If ADOT has reason to believe that the Developer is charging an unreasonable rate, ADOT will provide the Developer Notice thereof, and the Parties shall meet to discuss ADOT's concerns. The Developer shall provide ADOT with all information reasonably necessary for ADOT to determine whether the Developer is satisfying this Section 6.2.2. If ADOT requests, the Developer shall develop and implement a corrective action plan related thereto. Repeated noncompliance with this reasonable charging fee requirement shall be considered a Developer Default.

ARTICLE 7. DATA, PRIVACY AND CYBERSECURITY

7.1 Data Reporting

7.1.1 The Developer shall provide submit to EV-ChART, as described further in Exhibit 2-3 (Data Requirements) [with respect to each applicable Project Site]:

(a) a one-time report that includes all data required in the NEVI Federal Rule ("**One-time Data Submittal**") as set out under Section 4 (Data Submittal) of the NEVI Federal Standards and Requirements and Section 8 (Data Requirements) of the ADOT Standards and Requirements, as a condition to achieving Services Commencement;

(b) a quarterly report that includes all data required in the NEVI Federal Rule ("**Quarterly Data Submittal**") as set out under Section 4 (Data Submittal) of the NEVI Federal Standards and Requirements and Section 8 (Data Requirements)

of the ADOT Standards and Requirements, within seven Business Days after the end of each Calendar Quarter; and

(c) an annual report that includes an updated Data Interface Control Document, along with all data required in the NEVI Federal Rule (“**Annual Data Submittal**”) as set out under Section 4 (Data Submittal) of the NEVI Federal Standards and Requirements and Section 8 (Data Requirements) of the ADOT Standards and Requirements, within 15 Business Days after the end of each calendar year.

7.1.2 The Developer shall develop as a condition to achieving Services Commencement, and maintain during the O&M Period, an API to share applicable data (“**Third-Party Data Sharing**”) in a machine-readable format with federal partners, third-party software developers, ADOT, and other requesting parties free of charge as set out under Section 6(c) (Third-Party Data Sharing) of the NEVI Federal Standards and Requirements and Section 8 (Data Requirements) of the ADOT Standards and Requirements.

7.2 Data Audits. ADOT reserves the right to audit any and all data submitted by the Developer in accordance with Section 7.1 (Data Reporting) and other data submitted as part of any D&C Progress Report or Quarterly Performance Report.

7.3 Privacy and Cybersecurity. The Developer shall be responsible for cybersecurity as it relates to owning, operating, maintaining, and data sharing for the Project. The Developer shall comply at all times with the NEVI Federal Standards and Requirements and the ADOT Standards and Requirements as they relate to cybersecurity, including through the development and implementation of the Cybersecurity Plan. The Developer’s Cybersecurity Plan must comply with and satisfy the requirements set forth in the Cybersecurity Specifications.

ARTICLE 8. PAYMENTS

8.1 Services Commencement Payment.⁹

8.1.1 [For each Project Site,] subject to the requirements set forth in this Section 8.1, ADOT will pay the Developer an amount in consideration for D&C Work properly performed (“**Services Commencement Payment Amount**”). The Services Commencement Payment Amount shall be calculated as follows:

(a) the lesser of (i) \$[●]¹⁰ and (ii) eighty percent (80%) of Eligible Costs incurred during the D&C Period (“**Services Commencement Payment**”); less

⁹ **NOTE TO PROPOSERS:** This section will be revised to clarify appropriate amounts on a site-by-site basis in the case that a Project Agreement covers multiple Project Sites.

¹⁰ **NOTE TO PROPOSERS:** This amount will be equal to Row 13 of ITP Form 6-2 of the Developer.

(b) twenty percent (20%) of the Services Commencement Payment (the “Services Commencement Retainage”), payable to Developer in accordance with Section 8.2 (O&M Payments); less

(c) Performance Deductions in respect of the D&C Period determined in accordance with Section 8.5 (Limitations, Deductions and Withholdings); less

(d) any other undisputed amounts owed by the Developer to ADOT under this Agreement, including in respect of any indemnity claim under Section 13.1 (Indemnity by the Developer).

8.1.2 Following Services Commencement, the Developer may include with the final D&C Period Progress Report delivered in accordance with Section 5.2 (D&C Period Reporting) [for the applicable Project Site], an invoice for the Services Commencement Payment Amount (“**Services Commencement Payment Invoice**”) in a form reasonably acceptable to ADOT.

8.1.3 Within 30 Business Days after receipt of the Services Commencement Payment Invoice and the supporting final D&C Period Progress Report, ADOT will review the Eligible Cost information, and either:

(a) approve the Services Commencement Payment Invoice as submitted by the Developer; or

(b) adjust the Services Commencement Payment Amount claimed by the Developer and return the adjusted Services Commencement Payment Invoice to the Developer for countersignature.

8.1.4 Subject to Section 8.4 (Reimbursement Principle), ADOT will pay the Developer the agreed Services Commencement Payment Amount no later than the Developer Cycle Key Date first occurring after 30 days following (a) ADOT's approval of the Services Commencement Payment Invoice pursuant to Section 8.1.3(a), or (b) ADOT's adjustment of the Services Commencement Payment Invoice in accordance with Section 8.1.3(b) and receipt of the Developer's countersignature, as applicable.

8.2 O&M Payments.

8.2.1 [For each Project Site,] ADOT will pay the Developer a yearly amount during the O&M Period in consideration for O&M Work properly performed (“**O&M Payment Amount**”). Each O&M Payment Amount shall be calculated as follows:

(a) the lesser of (i) the Annual O&M Amount for the applicable year; and (ii) eighty percent (80%) of the Eligible Costs incurred for such year (“**O&M Payment**”); plus

(b) twenty percent (20%) of the Services Commencement Retainage; less

(c) Performance Deductions in respect of the O&M Period determined in accordance with Section 8.5 (Limitations, Reductions and Withholdings); less

(d) any other undisputed amounts owed by the Developer to ADOT under this Agreement, including in respect of any indemnity claim under Section 13.1 (Indemnity by the Developer).

8.2.2 The Developer shall submit to ADOT one invoice per year [per Project Site] in a form approved by ADOT for the applicable O&M Payment Amount allocable to the prior year (“**O&M Payment Invoice**”) beginning on the date that falls 30 days prior to the date that is one year after the Services Commencement Date [for the applicable Project Site]. [The Developer shall calculate the O&M Payment Amount in accordance with Section 8.2.1, including applicable Performance Deductions and other amounts owed pursuant to clauses (c) and (d) of Section 8.2.1].

8.2.3 Within 30 Business Days after receipt of [the][each] O&M Payment Invoice, ADOT will review the Eligible Cost information, and either:

(a) approve the O&M Payment Invoice as submitted by the Developer; or

(b) adjust the O&M Payment Amount claimed by the Developer, and return the adjusted O&M Payment Invoice to the Developer for countersignature.

8.2.4 Subject to Section 8.4 (Reimbursement Principle), ADOT will pay the Developer the agreed O&M Payment Amount no later than the Developer Cycle Key Date first occurring after 30 days following (a) ADOT's approval of the O&M Payment Invoice pursuant to Section 8.2.3(a), or (b) ADOT's adjustment of the O&M Payment Invoice in accordance with Section 8.2.3(b) and receipt of the Developer's countersignature, as applicable.

8.3 Project Payment Cap. The Parties acknowledge and agree that the aggregate total of the Services Commencement Payments and the O&M Payments [for each applicable Project Site] paid by ADOT to the Developer under this Agreement shall not exceed the Project Payment Cap [applicable to such Project Site], subject to deduction of any Performance Deductions and accrued Developer liabilities pursuant to this Agreement.

8.4 Reimbursement Principle. The Developer acknowledges that:

8.4.1 Developer costs submitted for reimbursement in accordance with this ARTICLE 8 (Payments) will be reviewed for eligibility in accordance with Section 4.1 (NEVI Federal Standards and Requirements);

8.4.2 reimbursement by ADOT of the Developer's costs in accordance with this ARTICLE 8 (Payments) is subject to receipt of corresponding funds from FHWA. In the event FHWA is delayed in disbursing such funds to ADOT for any reason, ADOT will reimburse the Developer's costs within 30 days of the date ADOT receives the funds from FHWA; and

8.4.3 ADOT's payment obligations under this Agreement are conditioned upon the availability of funds appropriated and allocated for the payment of such obligations. If funds are not appropriated, allocated and available or if the appropriation is changed by legislature, resulting in funds no longer being available for the continuance of this Agreement, ADOT may terminate this Agreement pursuant to Section 14.5 at the end of the period for which funds are available. No liability shall accrue to ADOT, the State, or any other agency of the State in the event this provision is exercised, and neither ADOT, the State, nor any other agency of the State shall be obligated or liable for any future payments or for any damages as a result of termination under this subsection.

8.5 Limitations, Deductions and Withholdings

8.5.1 ADOT may deduct from any payment of the Services Commencement Payment Amount or O&M Payments hereunder:

- (a) any ADOT or third-party Losses for which Developer is responsible hereunder;
- (b) any Performance Deductions that have accrued as of the date of the Services Commencement Payment Invoice or O&M Invoice, as applicable;
- (c) any sums expended by ADOT in performing any of the Developer's obligations under the Contract Documents that Developer has failed to perform; and
- (d) any other sums that ADOT is entitled to recover from Developer under the terms of this Agreement.

8.5.2 The failure by ADOT to deduct any of the sums set forth in this Section 8.5 from a payment shall not constitute a waiver of ADOT's right to such sums. Any amounts that the Developer owes ADOT hereunder shall be due and payable by the Developer promptly, and in any event, within 10 days after, ADOT's issuance of an invoice therefor.

ARTICLE 9.
**NONCOMPLIANCE EVENTS AND PERFORMANCE DEDUCTIONS; QUARTERLY
PERFORMANCE REPORTING DURING THE O&M PERIOD**

9.1 Noncompliance Event for Failure to Report.

9.1.1 In the event that the Developer fails to comply with the reporting obligations under Section 5.2 (D&C Period Reporting), Section 7.1 (Data Reporting), or Section 9.6 (Quarterly Performance Reporting during the O&M Period), ADOT may provide the Developer with 10 Business Days' advance Notice from the date of such failure that ADOT intends to assess a Performance Deduction, and directing remedy of the Noncompliance Event.

9.1.2 The Developer shall remedy the Noncompliance Event promptly, and in any event, no later than 10 Business Days after receipt of Notice from ADOT in accordance with Section 9.1.1. If the Developer fails to rectify the Noncompliance Event within the required timeframe, ADOT will assess Performance Deductions in accordance with Section 9.3 (Performance Deductions Assessment Process).

9.2 Noncompliance Event for Failure to Adhere to the NEVI Federal Uptime Requirement. In the event that the Developer fails to adhere to the NEVI Federal Uptime Requirement in an O&M Year [with respect to any Project Site], no ADOT notice will be required and ADOT will assess Performance Deductions in respect of such O&M Year [for such Project Site] in accordance with Section 9.3 (Performance Deductions Assessment Process).

9.3 Performance Deductions Assessment Process

9.3.1 The Developer's liability to ADOT for the applicable Performance Deductions shall be calculated in accordance with Exhibit 4 (Performance Deductions).

9.3.2 The Developer acknowledges that the Developer shall be liable for and pay Performance Deductions to ADOT at the time specified in Section 9.1 (Noncompliance Event for Failure to Report) or Section 9.2 (Noncompliance Event for Failure to Adhere to the NEVI Federal Uptime Requirement), as applicable, even though cure or remedy occurs at a later date.

9.4 Remedial Plans. Without prejudice to any other rights ADOT may have under this Agreement, if the Developer fails to satisfy the Minimum Quarterly Uptime Requirement in a Calendar Quarter [with respect to any Project Site], the Developer shall promptly develop a remedial plan setting forth the steps that the Developer will take in order to satisfy the Minimum Quarterly Uptime Requirement in future Calendar Quarters (each such plan, a "**Remedial Plan**"), and the Developer shall submit the Remedial Plan to ADOT for approval no later than 15 days after the conclusion of such Calendar Quarter. ADOT may approve the Remedial Plan or require that the Developer make modifications thereto. Upon ADOT's approval of the Remedial Plan, the Developer shall adhere to such Remedial Plan in the performance of the Work [with

respect to the applicable Project Site]. Failure of the Developer to comply with an approved Remedial Plan shall be deemed a Developer Default.

9.5 Acknowledgements Regarding Performance Deductions. The Parties agree that:

9.5.1 as of the Effective Date, the amount of Performance Deductions represent good faith estimates and evaluations by the Parties as to the actual potential damages that ADOT would incur as a result of a Noncompliance Event, and do not constitute a penalty or otherwise operate as a deterrent to the breach of any obligations of the Developer under this Agreement;

9.5.2 they have agreed to such Performance Deductions in order to fix and limit the Developer's costs and to avoid later disputes about what amounts of damages are properly chargeable to the Developer;

9.5.3 such sums are reasonable in light of the anticipated or actual harm caused by a Noncompliance Event, the difficulties of the proof of loss, and the inconvenience or infeasibility of otherwise obtaining an adequate remedy;

9.5.4 such Performance Deductions are reasonable, as determined as of the Effective Date, in light of the respective injuries and damages that may be caused by a Noncompliance Event, which include public inconvenience, increased administration and oversight by ADOT (and any other related agencies), and other damages to the general public and ADOT (and other related agencies), including potential harm and detriment to those using the Project, which may include loss of use, enjoyment and benefit of the Project; and

9.5.5 such Performance Deductions are not intended to, and do not, liquidate the Developer's liability under any indemnity provided by the Developer under this Agreement, even though Third-Party Claims against Indemnified Parties may arise out of the same event or breach or failure that gives rise to such Performance Deductions.

9.6 Quarterly Performance Reporting during the O&M Period.

9.6.1 No later than seven Business Days after the end of each Calendar Quarter following the Services Commencement Date, the Developer shall submit to EV-ChART the Quarterly Performance Report for the prior Calendar Quarter; provided, however, that the Developer shall submit directly to ADOT any information required to be provided in the Quarterly Performance Report that the Developer is not able to submit through EV-ChART.

9.6.2 The Quarterly Performance Report must contain the information required by Exhibit 5 (Performance Reports), Part B (Quarterly Performance Report).

9.7 ADOT Right to Dispute Quarterly Performance Report.

9.7.1 Within 10 days of receipt of the Quarterly Performance Report, ADOT will notify the Developer in writing if there is any part of the Quarterly Performance Report that ADOT disputes as inaccurate or noncompliant with the terms of this Agreement, and ADOT will submit to the Developer such supporting evidence as ADOT may have in respect of any such disputed part.

9.7.2 If ADOT provides a Notice pursuant to Section 9.7.1, the Developer shall either:

(a) promptly update the Quarterly Performance Report to take into account ADOT's comments provided pursuant to Section 9.7.1 and deliver such revised report to ADOT; or

(b) promptly notify ADOT that it disagrees with such notice, in which case the Parties shall conduct good faith negotiations to resolve the disagreement.

9.7.3 The Developer shall resolve all disputes described in a Notice issued under Section 9.7.1 no later than five days after receipt of such Notice.

ARTICLE 10. RELIEF EVENTS

10.1 Entitlement to Claim. If a Relief Event directly causes, or is likely to directly cause, the Developer to do any one or more of the following:

10.1.1 fail to achieve Services Commencement [of any Project Site] by the [applicable] Services Commencement Deadline;

10.1.2 fail to perform any of its obligations during the O&M Period [for a Project Site]; or

10.1.3 otherwise fail to comply with any of its obligations or exercise any of its rights under this Agreement, the Developer may claim one or more of the following in accordance with this ARTICLE 10 (Relief Events):

(a) an extension to the Services Commencement Deadline [for the applicable Project Site];

(b) relief from Performance Deductions; or

(c) relief from any rights of ADOT under Section 14.3 (Termination for Developer Default).

10.2 Notice and Information.

10.2.1 The Developer shall comply with the procedures in this Section 10.2 to claim an extension of time or relief from its obligations with respect to a Relief Event.

10.2.2 The Developer shall submit a notice that complies with Section 10.2.3 (a “**Relief Event Notice**”) to ADOT promptly (and in any event within 30 days) after the date that the Developer first became aware that the relevant Relief Event had occurred and would have the effect that is the subject of the Developer’s claim.

10.2.3 A Relief Event Notice must include, to the maximum extent of the information then available:

- (a) full details of the relevant Relief Event;
- (b) full details of the extension of time or relief from any rights of ADOT claimed or reasonably likely to be claimed (as applicable) under this ARTICLE 10 (Relief Events);
- (c) the provisions of the Contract Documents applicable to, governing, or otherwise affecting or affected by the Relief Event;
- (d) a time impact analysis (based on the then current Project Schedule) demonstrating that the relevant Relief Event will result in an identifiable and measurable disruption to the D&C Work, which will extend the time required to achieve Services Commencement; and
- (e) details of any steps that the Developer has taken or will take to mitigate the effect of the Relief Event in accordance with Section 10.3 (Mitigation).

10.3 Mitigation. The Developer shall use reasonable efforts to mitigate the delay and any other consequences of any Relief Event that is the subject of a notice pursuant to Section 10.2 (Notice and Information).

10.4 Failure to Provide Required Notice or Information. If any notice or information is not provided to ADOT in accordance with the requirements of Section 10.2 (Notice and Information), then for the relevant Relief Event and without prejudice to any other rights or remedies of ADOT under this Agreement:

10.4.1 the Developer will not be entitled to any extension of time or relief from its obligations under this Agreement to the extent that the quantum thereof was increased or the ability to mitigate was adversely affected as a result of such notice or information not being provided to ADOT in accordance with the requirements of Section 10.2 (Notice and Information); and

10.4.2 if the delay in providing such notice or information in accordance with the requirements of Section 10.2 (Notice and Information) is 60 days or more, the rights of the Developer with respect to such Relief Event will be of no further force or effect.

10.5 Grant of Relief.

10.5.1 The Developer will be entitled to an extension of time or other relief from obligations (as applicable) in accordance with Section 10.5.2 only if the Developer has satisfied all of the following:

(a) complied with its obligations under Section 10.2 (Notice and Information) and Section 10.3 (Mitigation);

(b) demonstrated to the reasonable satisfaction of ADOT that a Relief Event has occurred; and

(c) demonstrated to the reasonable satisfaction of ADOT that the Relief Event was the direct cause or is reasonably likely to be the direct cause of:

(i) a delay in achieving Services Commencement by the Services Commencement Deadline [for the applicable Project Sites];

(ii) failure to perform any of its obligations during the O&M Period [for the applicable Project Sites]; or

(iii) the Developer's inability to comply with its obligations under this Agreement.

10.5.2 If the Developer satisfies the conditions set out in Section 10.5.1, the Developer will be entitled to an extension of time or other relief from obligations (as applicable), as follows:

(a) in the case of a delay demonstrated pursuant to Section 10.2 (Notice and Information), the Services Commencement Deadline [for the applicable Project Site] will be extended by such time as is reasonable for such a Relief Event;

(b) any Performance Deductions that would not have been assessed by ADOT but for the occurrence of the Relief Event will be deemed to not have occurred for the purposes of this Agreement; and

(c) if any Developer Default or breach of this Agreement would not have occurred but for the occurrence of the Relief Event, such Developer Default or breach will be deemed to have not occurred for the purposes of this Agreement.

10.5.3 Within 30 days after receipt of any final Relief Event Notice, ADOT will notify the Developer of its determination as to the Developer's entitlement to any extension of time or other relief under this Section 10.5.

10.6 Sole Remedy. The Developer's sole remedy in relation to any Relief Event will be the operation of this ARTICLE 10 (Relief Events).

ARTICLE 11. INSURANCE

11.1 Insurance Policies. The Developer shall at its own expense maintain, or cause to be obtained and maintained, with the Developer as a named insured, at a minimum, each of the insurance policies set out in Exhibit 6 (Insurance) (the "**Developer Required Insurance**") satisfying the requirements set forth in this ARTICLE 11 (Insurance).

11.2 Waiver of Subrogation. The Developer Required Insurances shall each include a waiver of subrogation in favor of ADOT, the State and the Indemnified Parties. Each policy with insureds in addition to the Developer shall also provide that coverage for any other insured is primary and non-contributory with regard to other insurance.

11.3 Notice of Cancellation. Notice of cancellation to ADOT shall be provided by all insurers writing the Developer Required Insurance policies for any cancellation, material reduction in coverage or limit, or termination initiated by the insurer with at least 30 days' notice (and at least 10 days' notice for nonpayment).

11.4 Evidence of Coverage. The Developer shall provide evidence of compliant coverage, in the form of an updated ACORD certificate of insurance, prior to starting any Work and at each anniversary at least seven days prior to expiration. ADOT retains the right to request copies of the actual insurance policies and endorsements, and the Developer agrees to provide same within 10 days of such request.

11.5 Coverage Requirements. Coverage need not be project-specific unless otherwise noted above. The coverage requirements required under this ARTICLE 11 (Insurance) are minimums, and the Developer may purchase additional coverage or limits. ADOT will not be responsible for any premiums, deductibles, self-insured retentions or coinsurance amounts associated with any Developer Required Insurances. The Developer may be subject to additional insurance requirements from lenders or landlords and those shall supersede these requirements provided all such insurance shall also comply with the requirements herein.

11.6 Qualified Insurers. Each of the Developer Required Insurance policies hereunder shall be procured from an insurer that, at the time coverage under the applicable Insurance Policy commences:

11.6.1 is licensed or authorized to do business in the State pursuant to A.R.S. Title 20, Chapter 2, Article 1, or is a surplus lines insurer approved and identified by the director of the Arizona Department of Insurance pursuant to A.R.S., Title 20, Chapter 2, Article 5;

11.6.2 has a current policyholder's management and financial size category rating of not less than "A-, VII" according to A.M. Best and Company's Insurance Reports Key Rating Guide or, with respect only to worker's compensation insurance, is duly authorized to transact such insurance in the State; or

11.6.3 is otherwise approved in writing by ADOT in its reasonable discretion.

ARTICLE 12. PERFORMANCE AND PAYMENT SECURITY

12.1 Provision of Bonds during D&C Period. The Developer shall provide to ADOT performance and payment bonds securing the Developer's obligations during the D&C Period, and the Developer shall maintain such bonds in full force and effect as described in this Section 12.1 (Provision of Bonds during D&C Period).

12.1.1 D&C Performance Bond

(a) On or before the Effective Date, the Developer shall have delivered to ADOT the D&C Performance Bond in the amount of \$[●].¹¹

(b) ADOT will provide a release of the D&C Performance Bond on the date that is one year after the Services Commencement Date, provided that (and upon such date thereafter that) all of the following have occurred:

(i) there exists no disputed claim by ADOT against the Developer relating to the D&C Work or other obligations of the Developer arising during the D&C Period;

(ii) there exists no Developer Default; and

(iii) no event has occurred that with the giving of notice or passage of time, or both, would constitute a Developer Default.

12.1.2 D&C Payment Bond

¹¹ **NOTE TO PROPOSERS:** Amount shall be equal to the aggregate of Rows 12 under "Total Capital Costs" of ITP Forms 6-2 of the Developer for all applicable Project Sites.

(a) On or before the Effective Date, Developer shall have delivered to ADOT the D&C Payment Bond in the amount of \$[●].¹²

(b) ADOT will provide a release of the D&C Payment Bond upon:

(i) receipt of (A) evidence satisfactory to ADOT that all Persons eligible to file a claim against the D&C Payment Bond have been fully paid, and (B) unconditional releases of claims and stop notices from all Subcontractors who filed preliminary notices of claims against the D&C Payment Bond (or evidence satisfactory to ADOT that any such claims and stop notices have been secured by a separate bond(s) issued by a Surety that meets the requirements of Section 12.3 (Eligible Security Issuer)); and

(ii) expiration of the statutory period for Subcontractors to file a claim against the D&C Payment Bond, if no claims have been filed.

12.2 Performance Security during O&M Period.

12.2.1 As a condition to the occurrence of the Services Commencement Date, the Developer shall furnish a bond or letter of credit in an amount equal to \$[●]¹³ ("**O&M Performance Security**"), in a form and substance reasonably approved by ADOT, as security for the obligations of the Developer to pay any Termination Sum in accordance with Section 14.4 (Compensation on Termination) or for the cost for ADOT to ensure that the decommissioning activities are completed in accordance with Section 4.3.2 (Project Site Expiry Date Obligations).

12.2.2 The O&M Performance Security must be issued by an eligible security issuer as defined in Section 12.3 (Eligible Security Issuer).

12.2.3 The Developer shall maintain the O&M Performance Security until the date 30 days following the end of the Term. The O&M Performance Security may be on terms that provide for incremental reduction of the secured amount on an annual basis based on the corresponding reductions in the Termination Sum calculated in accordance with Section 14.4.2.

12.3 Eligible Security Issuer

12.3.1 Each Project Bond shall be issued by a Surety that is:

(a) licensed and authorized to do business in the State;

¹² **NOTE TO PROPOSERS:** Amount shall be equal to the aggregate of Rows 12 under "Total Capital Costs" of ITP Forms 6-2 of the Developer for all applicable Project Sites.

¹³ **NOTE TO PROPOSERS:** Amount shall be equal to the maximum termination compensation amount as determined pursuant to Section 14.4.2.

(b) listed on the “Department of the Treasury’s Listing of Approved Sureties (Department Circular 570)” (found at www.fiscal.treasury.gov/fsreports/ref/suretybnd/c570.htm); and

(c) rated in one of the top two categories by at least two nationally-recognized rating agencies (Fitch Ratings, Moody’s Investor Service and Standard & Poor’s); or rated at least A minus (“A-”) or better and Class VIII or better according to A.M. Best and Company’s Financial Strength Rating and Financial Size Category, or as otherwise approved by ADOT in its sole discretion.

12.3.2 Any letter of credit provided pursuant to Section 12.2 (Performance Security during O&M Period) must be provided by a Person that has: (i) a long-term unsecured debt rating of at least the following, from at least one of the following Rating Agencies: (1) “A-” by Standard & Poor’s Rating Services; (2) “A3” by Moody’s Investor Services, Inc.; or (3) “A-” by Fitch Investor Services, Inc.; and (ii) an office in the State at which the letter of credit can be presented for payment, unless presentment by facsimile or by electronic means is permitted without the requirement to subsequently present in person; and

12.3.3 If any Project Bond or letter of credit previously provided hereunder becomes ineffective, or if the Surety or letter of credit provider that provided the Project Bond or letter of credit, as applicable, no longer meets the foregoing requirements, the Developer shall provide a replacement Project Bond or letter of credit, as applicable, in the same form, issued by a Surety meeting the foregoing requirements, or other assurance satisfactory to ADOT in its sole discretion. If any Project Bond is provided by co-Sureties and at least one of the co-Sureties meets the foregoing requirements and is liable for the full amount of such Project Bond, then no replacement bond shall be required so long as such co-Surety continues to meet the foregoing requirements and remains liable for the full amount of such Project Bond.

ARTICLE 13. INDEMNIFICATION

13.1 Indemnity by the Developer

13.1.1 Subject to Section 13.2 (Defense and Indemnification Procedures), to the fullest extent permitted by applicable Law, the Developer shall release, protect, defend, indemnify and hold harmless the Indemnified Parties from and against any and all Third-Party Claims arising out of, relating to or resulting from:

(a) the breach or alleged breach of any of the Contract Documents by any Developer-Related Entity, including as a result of the performance of the Work at the Project Site;

(b) the failure or alleged failure by the Developer or any Developer-Related Entity to comply with the Governmental Approvals, the NEPA Approval[s], any applicable Laws or the NEVI Federal Standards and Requirements;

(c) any actual or alleged patent or copyright infringement or other actual or alleged improper appropriation or use of trade secrets, patents, proprietary information, know-how, copyright rights or inventions by the Developer or any Developer-Related Entity in performance of the Work;

(d) the actual or alleged act or omission, error or misconduct of the Developer or any Developer-Related Entity in or associated with performance of the Work;

(e) any and all claims by any Governmental Entity or taxing authority claiming taxes based on gross receipts, purchases or sales, or the use of any property or income of any Developer-Related Entity with respect to any payment for the Work made to or earned by any Developer-Related Entity;

(f) the failure or alleged failure by any Developer-Related Entity to pay sums due for the work or services, materials, goods, equipment or supplies of Subcontractors, laborers, or suppliers, including in relation to any stop notices, liens and claims filed by such Subcontractors in connection with the Work;

(g) any actual or threatened Developer release of hazardous materials;

(h) (i) any Developer-Related Entity's breach of or failure to perform an obligation that ADOT or any Indemnified Party owes to a third person, including Governmental Entities, under Law or under any agreement between ADOT and a third person, where ADOT has delegated performance of the obligation to the Developer under the Contract Documents, or (ii) the acts or omissions of any Developer-Related Entity that render ADOT unable to perform or abide by an obligation that ADOT owes to a third person, including Governmental Entities, under any agreement between ADOT and a third person, where the agreement was disclosed or known to the Developer;

(i) inverse condemnation, trespass, nuisance, interference with use and enjoyment of real property or similar taking of or harm to real property by reason of: (i) the failure of any Developer-Related Entity to comply with Good Industry Practices, the requirements of the Contract Document or Governmental Approvals or the NEPA Approval[s] respecting control and mitigation of construction activities and construction impacts, (ii) the negligence or intentional misconduct of any Developer-Related Entity, (iii) the intentional misconduct or negligence of the Developer or any Developer-Related Entity, or (iv) the entry onto or encroachment upon another's property by any Developer-Related Entity;

(j) errors, inconsistencies or other defects in the design, construction, operations or maintenance of the Project; or

(k) any violation of any federal or state securities or similar laws by any Developer-Related Entity.

13.1.2 Subject to the releases and disclaimers herein, including all the provisions set forth in Section 1.3 (Reference Information Documents) of this Agreement, the Developer's indemnity obligation shall not extend to any Third-Party Claim to the extent directly caused by:

(a) the negligence, recklessness, intentional misconduct, bad faith or fraud of such Indemnified Party;

(b) ADOT's breach of any of its obligations under the Contract Documents; or

(c) an Indemnified Party's material violation of any Laws, Governmental Approvals or NEPA Approval[s].

13.1.3 In claims by an employee of a Developer-Related Entity, Subcontractor, anyone directly or indirectly employed by them or anyone for whose acts they may be liable, the indemnification obligation under this Section 13.1 (Indemnity by the Developer) shall not be limited by a limitation on the amount or type of damages, compensation or benefits payable by the Developer or a Developer-Related Entity under workers' compensation, disability benefit or other employee benefits laws.

13.1.4 The Developer hereby acknowledges and agrees that it is the Developer's obligation to perform the Work in accordance with the Contract Documents and that the Indemnified Parties are fully entitled to rely on the Developer's performance of such obligation. The Developer further agrees that any certificate, review or approval by ADOT or others hereunder shall not relieve the Developer of any of its obligations under the Contract Documents or in any way diminish its liability for performance of such obligations or its obligations under this Section 13.1 (Indemnity by the Developer).

13.1.5 The indemnity set forth in Section 13.1.1(g) is intended to operate as an agreement pursuant to the Comprehensive Environmental Response and Compensation and Liability Act, 42 U.S.C. § 9607(e), to insure, protect, hold harmless and indemnify the Indemnified Parties.

13.1.6 The obligations under this Section 13.1 (Indemnity by the Developer) shall not be construed to negate, abridge, or reduce other rights or obligations that would otherwise exist in favor of an Indemnified Party hereunder.

13.2 Defense and Indemnification Procedures.

13.2.1 If ADOT receives notice of a claim or otherwise has actual knowledge of a claim that it believes is within the scope of the indemnities under Section 13.1 (*Indemnity by the Developer*), then ADOT will have the right to conduct its own defense unless either an insurer accepts defense of the claim within the time required by Law or Developer accepts the tender of the claim in accordance with Section 13.2.3.

13.2.2 Subject to Section 13.2.6, if the insurer under any applicable Developer Required Insurance policy accepts the tender of defense, ADOT and the Developer shall cooperate in the defense as required by such policy. If no insurer under potentially applicable Developer Required Insurance provides defense, then Section 13.2.3 shall apply.

13.2.3 If the defense is tendered to the Developer, then within 15 days after receipt of the tender, the Developer shall notify the Indemnified Party whether the Developer has tendered the matter to an insurer. If the Developer does not tender the matter to an insurer, then within such 15 days, or if the insurer has rejected the tender, then within five days after such rejection, the Developer shall deliver a notice to the Indemnified Party stating one of the following:

(a) the Developer accepts the tender of defense and confirms that the claim is subject to full indemnification without any “reservation of rights” to deny or disclaim full indemnification thereafter;

(b) the Developer accepts the tender of defense but with a “reservation of rights,” in whole or in part, to deny or disclaim indemnification thereafter; or

(c) the Developer rejects the tender of defense based on a determination that it is not required to indemnify against the claim under the terms of this Agreement or any other agreement or obligation to provide indemnification.

13.2.4 If the Developer accepts the tender of defense under Section 13.2.3(a), the Developer shall have the right to select legal counsel for the Indemnified Party, subject to reasonable approval by the Indemnified Party, and the Developer shall otherwise control the defense of such claim, including settlement (subject to, in the case of settlement, the Indemnified Party’s prior approval), and bear the fees and costs of defending and settling such claim. During such defense:

(a) the Developer shall fully and regularly inform the Indemnified Party of the progress of the defense and of any settlement discussions; and

(b) the Indemnified Party shall fully cooperate in said defense, provide to the Developer all materials and access to personnel it requests as necessary for defense, preparation and trial and which or who are under the control of or

reasonably available to the Indemnified Party, and maintain the confidentiality of all communications between it and the Developer concerning such defense.

13.2.5 If the Developer responds to the tender of defense as specified in Section 13.2.3(b) or 13.2.3(c), the Indemnified Party shall be entitled to select its own legal counsel and otherwise control the defense of such claim, including settlement.

13.2.6 Notwithstanding Section 13.2.3(a) or Section 13.2.3(b), the Indemnified Party may assume its own defense by delivering to the Developer notice of such election and the reasons therefor, if the Indemnified Party, at the time it gives notice of the claim or at any time thereafter, reasonably determines that:

(a) a conflict exists between it and the Developer that prevents or potentially prevents the Developer from presenting a full and effective defense;

(b) the Developer is otherwise not providing an effective defense in connection with the claim; or

(c) the Developer lacks the financial capacity to satisfy potential liability or to provide an effective defense.

13.2.7 If the Indemnified Party is entitled and elects to conduct its own defense, then:

(a) In the case of a defense conducted under Section 13.2.3(a), it shall have the right to settle or compromise the claim with Developer's prior consent, which shall not be unreasonably withheld or delayed;

(b) In the case of a defense conducted under Section 13.2.3(b), it shall have the right to settle or compromise the claim (i) with Developer's prior consent, which shall not be unreasonably withheld or delayed, or (ii) with approval of the court or arbitrator following reasonable notice to the Developer and opportunity to be heard, without prejudice to the Indemnified Party's rights to be indemnified by the Developer; and

(c) In the case of a defense conducted under Section 13.2.3(c), it shall have the right to settle or compromise the claim without the Developer's prior consent and without prejudice to its rights to be indemnified by the Developer.

13.2.8 If the Indemnified Party is entitled and elects to conduct its own defense of a claim for which it is entitled to indemnification, the Developer shall reimburse all reasonable costs and expenses the Indemnified Party incurs in investigating and defending, including reimbursement of reasonable attorneys' fees and other litigation and defense costs. Except where Developer rejects defense pursuant to Section 13.2.3(c), the Developer shall reimburse such defense costs and expenses on a current basis.

13.2.9 A refusal of, or failure to accept, a tender of defense, as well as any dispute over whether an Indemnified Party that has assumed control of defense is entitled to do so under Section 13.2.7, shall be resolved according to Section 18.9.

13.2.10 The Parties acknowledge that while Section 13.1 (Indemnity by the Developer) contemplates that the Developer will have responsibility for certain claims and liabilities arising out of its obligations to indemnify, circumstances may arise in which there may be shared liability of the Parties with respect to such claims and liabilities. In such case, where either Party believes a claim or liability may entail shared responsibility and that principles of comparative negligence and indemnity are applicable, it shall confer with the other Party on management of such claim or liability. If the Parties cannot agree on an approach to representation in the matter in question, each shall arrange to represent itself and to bear its own costs in connection therewith pending the outcome of such matter. Within 30 days subsequent to the final, nonappealable resolution of the matter in question, whether by arbitration, judicial proceedings or otherwise, the Parties shall adjust the costs of defense, including reimbursement of reasonable attorneys' fees and other litigation and defense costs, in accordance with the indemnification arrangements of this Section 13.2 (Defense and Indemnification Procedures), and consistent with the outcome of such proceedings concerning the respective liabilities of the Parties on the Third-Party Claim.

13.2.11 In determining responsibilities and obligations for defending suits pursuant to this Section 13.2 (Defense and Indemnification Procedures), and to the extent consistent with applicable Law, specific consideration shall be given to the following factors: (a) the party performing the activity in question; (b) the location of the activity and incident; (c) contractual arrangements then governing the performance of the activity; and (d) allegations of respective fault contained in the claim.

13.3 Assignment of Claims to ADOT.

13.3.1 The Developer shall assign to ADOT any claim for overcharges resulting from antitrust violations to the extent that such violations concern materials or services supplied by third parties to the Developer toward fulfillment of this Agreement.

13.3.2 Notwithstanding any provision in this Agreement to the contrary, ADOT will not indemnify the Developer, any Developer-Related Entity, or any of their successors, assigns, officeholders, officers, directors, agents, representatives, consultants or employees, from any claims made against them.

**ARTICLE 14.
DEVELOPER DEFAULT**

14.1 Developer Default. The occurrence of any one or more of the following will constitute a “Developer Default”:

14.1.1 the Developer Abandons the Project;

14.1.2 [rights to use the Project Site under the Host Site Agreement are terminated for any reason, or the Developer assigns such rights in breach of its obligations under Section 4.3.1(d) (Property Interest)];¹⁴

14.1.3 the Developer fails to (i) begin Work authorized by ADOT’s issuance of a Notice to Proceed within 30 days following issuance thereof; or (ii) achieve Services Commencement by the Services Commencement Long Stop Date;

14.1.4 a Persistent Developer Default occurs;

14.1.5 the Developer fails to pay any amount due to ADOT under this Agreement when due, except to the extent such payment is subject to a good faith dispute;

14.1.6 the Developer fails to comply with any Governmental Approval, NEPA Approval or applicable Law in any material respect;

14.1.7 the Developer is in breach of its obligations under Section 18.4.2 (Successors and Assigns; Change of Control);

14.1.8 the Developer is in breach of its obligations under Section 15.5 (Prompt Payment);

14.1.9 an Insolvency Event arises with respect to the Developer;

14.1.10 any representation or warranty made by the Developer in this Agreement or any certificate, schedule, report, instrument or other document delivered to ADOT pursuant to this Agreement is false or materially misleading or inaccurate when made, in each case in any material respect, or omits material information when made;

14.1.11 the Developer fails to obtain, procure, provide and keep in effect the Developer Required Insurance, in accordance with the requirements set out in ARTICLE 11 (Insurance) and Exhibit 6 (Insurance);

¹⁴ **NOTE TO PROPOSERS:** Bracketed language to be included if Developer does not own the Project Site.

14.1.12 the Developer fails to obtain and maintain the Performance Security in accordance with the requirements of ARTICLE 12 (Performance and Payment Security);

14.1.13 after exhaustion of all rights of appeal, the Developer or any Subcontractor (at all tiers), other than any Subcontractor whose work in respect of the Project is complete, is or becomes a Prohibited Person;

14.1.14 the Developer otherwise fails to timely observe or perform or cause to be observed or performed any other covenant, agreement, obligation, term or condition required to be observed or performed by the Developer under the Contract Documents[, including, for the avoidance of doubt, completion of any decommissioning activities or payment of any Termination Sums due and owing by the Developer upon termination of this Agreement in part pursuant to Section 14.3 (Termination for Developer Default)]; or

14.1.15 the Developer fails to perform the Work in accordance with an approved Remedial Plan.

14.2 Notice and Cure Periods.

14.2.1 ADOT will provide written notice (“**Developer Default Notice**”) to the Developer upon the occurrence of a Developer Default.

14.2.2 Upon receipt of a Developer Default Notice, the Developer will have the following cure periods:

(a) for a Developer Default under Section 14.1.1 (Abandonment), Section 14.1.5 (Non-Payment), Section 14.1.8 (Prompt Payment), Section 14.1.11 (Insurance), and Section 14.1.12 (Performance Security), a period of 30 days after the Developer receives the Developer Default Notice;

(b) for a Developer Default under Section 14.1.3(i) (Failure to Commence Work), Section 14.1.6 (Governmental Approvals and NEPA Approval[s]), Section 14.1.10 (Representations and Warranties), Section 14.1.14 (Additional Failure to Perform), and Section 14.1.15 (Remedial Plan) (subject to Section 14.2.3 (Notice and Cure Periods)),

(i) a period of 30 days after the Developer receives the Developer Default Notice; or

(ii) if, despite the Developer’s commencement of meaningful steps to cure immediately after receiving the Developer Default Notice, the Developer Default cannot be cured within such 30-day period, the Developer will have such additional period of time, up to a maximum cure period of 90 days, as is reasonably necessary to cure the Developer Default; and

(c) for a Developer Default under Section 14.1.2 (Host Site Agreement Termination), Section 14.1.3(ii) (Services Commencement Long Stop Date), Section 14.1.4 (Persistent Developer Default), Section 14.1.7 (Assignment), Section 14.1.9 (Insolvency Event) and Section 14.1.13 (Prohibited Person) (except as provided for under Section 14.2.4 (Notice and Cure Periods)), there is no cure period.

14.2.3 A Developer Default under Section 14.1.10 (Representations and Warranties) will be regarded as cured when the adverse effects of such Developer Default are resolved.

14.2.4 In respect of a Developer Default under Section 14.1.13 (Prohibited Person), if the Prohibited Person is:

(a) a managing member, general partner or controlling investor of the Developer, cure will be regarded as complete when the Developer proves it has removed such Person from any position or ability to manage, direct or control the decisions of the Developer or to perform Work; or

(b) a Subcontractor, cure will be regarded as complete when the Developer or any employing Subcontractor replaces such Subcontractor.

14.3 Termination for Developer Default

14.3.1 If a Developer Default occurs and the Developer Default has not been cured within any relevant cure period set out in Section 14.2 (Notice and Cure Periods), ADOT may serve a termination notice (“**ADOT Termination Notice**”) on the Developer at any time during the continuance of such Developer Default. ADOT may, in its discretion, issue the ADOT Termination Notice with respect to the Agreement in whole or in part. [ADOT will be permitted, at its discretion, to terminate this Agreement with respect to any or all applicable Project Sites hereunder.]

14.3.2 An ADOT Termination Notice must specify the Developer Default that has occurred entitling ADOT to terminate, and whether the ADOT Termination Notice applies to the Agreement in whole or in part.

14.3.3 This Agreement will terminate [with respect to each applicable Project Site] on the date that is 30 days after the date the Developer receives an ADOT Termination Notice.

14.3.4 Prior to the Early Termination Date under this Section 14.3 (Termination for Developer Default), the Developer shall carry out all decommissioning activities in accordance with Section 13(b) (Decommissioning Activities) of the ADOT Standards and Requirements.

14.4 Compensation on Termination

14.4.1 If this Agreement is terminated [in whole or in part] pursuant to Section 14.3 (Termination for Developer Default) during the D&C Period, the Developer shall pay compensation to ADOT calculated as follows:

(a) if the Developer has not completed the decommissioning activities in accordance with Section 14.3 (Termination for Developer Default) prior to the Early Termination Date, ADOT's reasonable estimate of the cost for ADOT to ensure that the decommissioning activities are completed [for each applicable Project Site]; plus

(b) \$200,000 [for each Project Site that is terminated], representing a lump sum liquidated damage for ADOT's anticipated costs for procuring a replacement EV Charging Station under the Plan; plus

(c) any accrued liabilities of the Developer that arose prior to the Early Termination Date, including in respect of any indemnity claims under ARTICLE 13 (Indemnification) and any Performance Deductions assessed in accordance with Section 9.3 (Performance Deductions Assessment Process) (to the extent not already deducted from any payments made by ADOT hereunder).

14.4.2 If this Agreement is terminated [in whole or in part] pursuant to Section 14.3 (Termination for Developer Default) during the O&M Period, the Developer shall pay compensation to ADOT calculated as follows:

(a) reimbursement of a portion of the total payments made by ADOT to Developer under the Contract Documents [with respect to the applicable Project Sites that are terminated] in accordance with the following table:

Date of Occurrence of Early Termination Date	% of Payments to Developer	Amount Payable by Developer
Prior to first anniversary of Services Commencement Date	100% ¹⁵	[\$●]
On or after the first anniversary and prior to the second anniversary of	80%	[\$●]

¹⁵ **NOTE TO PROPOSERS:** Amount to be determined based on the portion of the Project Payment Cap paid prior to the fifth anniversary of the Services Commencement Date (i.e., the termination compensation shall account for the maximum compensation payable by ADOT to Developer during the O&M Period).

Date of Occurrence of Early Termination Date	% of Payments to Developer	Amount Payable by Developer
the Services Commencement Date		
On or after the second anniversary and prior to the third anniversary of the Services Commencement Date	60%	\$[●]
On or after the third anniversary and prior to the fourth anniversary of the Services Commencement Date	40%	\$[●]
On or after the fourth anniversary and prior to the fifth anniversary of the Services Commencement Date	20%	\$[●]

; plus

(b) if the Developer has not completed the decommissioning activities in accordance with Section 14.3.4 (Termination for Developer Default) prior to the Early Termination Date, ADOT’s reasonable estimate of the cost for ADOT to ensure that the decommissioning activities are completed [for each applicable Project Site]; plus

(c) \$200,000 [for each Project Site that is terminated], representing a lump sum liquidated damage for ADOT’s anticipated costs for procuring a replacement EV Charging Station under the Plan; plus

(d) any accrued liabilities of the Developer that arose prior to the Early Termination Date, including in respect of any indemnity claims under ARTICLE 13 (Indemnification) and any Performance Deductions assessed in accordance with Section 9.3 (Performance Deductions Assessment Process) (to the extent not already deducted from any O&M Payment prior to the Early Termination Date).

14.4.3 The Developer shall pay the Termination Sum calculated in accordance with Section 14.4.1 or Section 14.4.2, as applicable, by no later than the date of termination in accordance with Section 14.3.3 (Termination for Developer Default).

14.4.4 If the Developer has not paid the Termination Sum in accordance with Section 14.4.3, ADOT will have the right to call or draw on the O&M Performance Security for the amount of the Termination Sum.

14.4.5 The Parties acknowledge and agree that the provisions for the calculation of the Termination Sum represent good faith estimates and evaluations as

to the actual potential damages ADOT would incur as a result of the Early Termination of this Agreement due to Developer Default, and do not constitute a penalty.

14.5 Termination for Convenience.

14.5.1 ADOT may terminate the Agreement in whole or in part for convenience at its discretion by serving an ADOT Termination Notice on the Developer at any time indicating that such Termination Notice is issued pursuant to this Section 14.5.

14.5.2 ADOT will compensate the Developer for all Work that was properly performed in accordance with the terms of this Agreement prior to the date of the ADOT Termination Notice or such other date as the ADOT Termination Notice specifies.

14.5.3 Prior to the Early Termination Date under this Section 14.5, the Developer shall carry out all decommissioning activities in accordance with Section 13(b) (Decommissioning Activities) of the ADOT Standards and Requirements.

ARTICLE 15. SUBCONTRACTING AND LABOR PRACTICES

15.1 Labor Standards.

15.1.1 The Developer shall in carrying out the Work comply, and cause each Subcontractor to comply, with all applicable federal and State labor, occupational safety and health standards, rules, regulations, and federal and State orders.

15.1.2 The Developer shall ensure that any individual performing the Work has the skill and experience and any licenses or certifications required in order to perform the Work assigned to such individual.

15.1.3 If any individual employed by the Developer or any Subcontractor is not performing the Work in a proper, safe and skillful manner, then the Developer shall, or shall cause such Subcontractor to, remove such individual and such individual shall not be reemployed on the Work. If, after notice and reasonable opportunity to cure, such individual is not removed or if the Developer fails to ensure that skilled and experienced personnel are furnished for the proper performance of the Work, then ADOT may suspend the affected portion of the Work by delivery of notice of such suspension to the Developer. Such suspension shall be considered a suspension for cause and shall in no way relieve the Developer of any obligation contained in the Contract Documents or entitle Developer to relief hereunder.

15.1.4 The Developer shall, and shall cause each Subcontractor to, provide ADOT with any and all information ADOT requires to comply with applicable

Law, including any information ADOT may need to complete Form FHWA 1494, Labor Compliance Enforcement Report.

15.2 Nondiscrimination; Equal Employment Opportunity.

15.2.1 The Developer shall comply, and shall cause the Developer-Related Entities to comply, with all applicable State and federal civil rights laws, including Arizona Executive Order 2009-09.

15.2.2 The Developer shall not, and shall cause the Developer-Related Entities to not discriminate on the basis of race, creed, age, color, religion, sex, national origin or disability in the performance of the Work.

15.2.3 The Developer and the Developer-Related Entities shall not discriminate against any employee or applicant for employment because of race, creed, age, color, religion, sex, national origin or disability. The Developer will take affirmative action to ensure that applicants are employed and that employees are treated during employment without regard to their race, creed, age, color, religion, sex, national origin or disability. Such action shall include, but is not limited to, the following: employment, upgrading, demotion or transfer, recruitment or recruitment advertising, layoff or termination, rates of pay or other forms of compensation, and selection for training, including apprenticeship. The Developer shall post in conspicuous places, available to employees and applicants for employment, notices setting forth the provisions of this nondiscrimination clause.

15.2.4 The Developer shall carry out, and shall cause each Subcontractor to carry out, applicable requirements of 49 CFR 26 et seq. in the award and administration of USDOT assisted contracts.

15.2.5 The Developer shall include Sections 15.2.1, 15.2.2, 15.2.3, and 15.2.4, in every Subcontract. The Developer shall additionally require that all Subcontractors include Sections 15.2.1, 15.2.2, 15.2.3, and 15.2.4 in each further subcontract (with appropriate changes in the names of the parties), so that such provisions will be binding upon each Subcontractor and every entity that performs any Work on the Project.

15.2.6 Failure by the Developer to carry out these requirements is a material breach of this Agreement, which may result in the termination of this Agreement or such other remedy as ADOT deems appropriate.

15.3 Responsibility for Developer-Related Entities. The retention of Subcontractors by the Developer will not relieve the Developer of its responsibility hereunder or for the quality of the Work or materials provided by it. The Developer shall supervise and be responsible for the acts, omissions, negligence, intentional misconduct, or breach of applicable Law, contract, NEPA Approval or Governmental Approval by any Developer-Related Entity, as though the Developer directly employed all such Persons. No Subcontract entered into by the Developer will impose any

obligation or liability upon ADOT to any such Subcontractor or any of its employees. Nothing in this Agreement creates any contractual relationship between ADOT and any Subcontractor.

15.4 Prevailing Wages.

15.4.1 The Developer shall:

(a) pay or cause to be paid to all applicable workers employed by it or its Subcontractors to perform the Work not less than the prevailing rates of wages, as provided in applicable Law in respect of public work contracts, including the Davis-Bacon Act, 29 CFR Part 5, and as provided in Exhibit 9, Part A (Federal Requirements), Federal Certifications, Attachment 3 (Federal Prevailing Wage Rate); and

(b) comply and cause its Subcontractors to comply with all applicable Law pertaining to prevailing wages and the Copeland “Anti-Kickback” Act, as supplemented by 29 CFR Part 3.

15.4.2 For the purpose of applying the applicable Law the Project shall be treated as a public work paid for in whole or in part with public funds (regardless of whether public funds are actually used to pay for the Project).

15.4.3 The provisions of Exhibit 9, Part A (Federal Requirements), Federal Certifications, Attachment 3 (Federal Prevailing Wage Rate) will apply to the entire Project during both the D&C Period and O&M Period and to all covered classifications of employees regardless of the contractual relationship between the Developer or the Subcontractors and laborers, mechanics or field surveyors.

15.4.4 It is the Developer’s sole responsibility to determine the wage rates required to be paid. In the event rates of wages and benefits change while this Agreement is in effect, the Developer shall bear the cost of such changes and shall have no claim against ADOT or the State on account of such changes.

15.4.5 The Developer shall comply, and cause its Subcontractors to comply, with all applicable Law regarding notice and posting of intent to pay prevailing wages, of prevailing wage requirements and of prevailing wage rates.

15.4.6 This Section 15.4 (Prevailing Wages) will not apply to Subcontracts with any Governmental Entity, if any.

15.5 Prompt Payment

15.5.1 The Developer shall comply and require its Subcontractors to comply with all applicable Laws with respect to prompt payment, including A.R.S. § 32-1183.

15.5.2 A breach by the Developer of this Section 15.5 (Prompt Payment) will constitute a Developer Default pursuant to Section 14.1 (Developer Default).

15.6 Suspension and Debarment Certifications

15.6.1 The Developer shall deliver to ADOT (a) no later than January 31 of each year during the Term; and (b) upon the Termination Date of the Project Agreement in whole, signed certifications substantially in the form of: Exhibit 9, Part A (Federal Requirements), Federal Certifications, Attachment 6 (Suspension and Debarment Certification) from (i) the Developer; and (ii) each affiliate of the Developer (where for the purposes of this clause (b) only, "affiliate" is defined in 2 CFR 180.905 or successor regulation of similar import).

15.6.2 The Developer shall provide immediate written notice to ADOT and provide all relevant information to ADOT, if at any time the Developer learns that a certification provided in accordance with this Section 15.6 (Suspension and Debarment Certifications) was erroneous when submitted or has become erroneous by reason of changed circumstances.

15.7 AZ UTRACS and DOORS Registration

The Developer shall require that all Subcontractors be registered in ADOT's AZ UTRACS system (accessible at utracs.azdot.gov) and ADOT's contract management system, DBE & Online Reporting System (DOORS) (accessible at <https://adotdoors.dbesystem.com>) as a condition to execution of any Subcontract.

15.8 Approval of Subcontracts

All Subcontracts are subject to ADOT's review and approval. The Developer shall not permit a Work to be performed by a Subcontractor unless the applicable Subcontract has been approved by ADOT in writing. All Subcontracts shall be evidenced in writing and contain all pertinent provisions and requirements of this Agreement.

15.9 Conflict of Interests

The Developer shall comply with A.R.S. § 38-511. ADOT may terminate this Agreement, without penalty or further obligation to ADOT, within three years after the Agreement is executed, if any person significantly involved in initiating, negotiating, securing, drafting or creating this Agreement on behalf of ADOT is or becomes, at any time during the Term of this Agreement, an employee or agent of the Developer.

ARTICLE 16.
RECORDS, AUDIT AND PUBLIC RECORDS

16.1 Maintenance and Inspection of Records

16.1.1 The Developer shall:

(a) keep and maintain Books and Records, including copies of all original documents delivered to ADOT in accordance with the applicable provisions of this Agreement and in accordance with Good Industry Practice; and

(b) notify ADOT where such books, records and documents are kept.

16.1.2 The Developer shall make all of its Books and Records available for inspection and audit by ADOT at all times during normal business hours, without charge. ADOT may conduct any such inspection or audit upon 48 hours' prior written notice, or unannounced and without prior notice where there is good faith suspicion of fraud or criminal activity. When conducting any inspection or audit, ADOT may make extracts and take notes.

16.1.3 The Developer shall provide copies of the Books and Records to ADOT as and when reasonably requested by ADOT and produce the original of any or all such Books and Records at ADOT offices.

16.1.4 The Developer shall comply with all applicable provisions in 2 CFR 200 related to retention of Books and Records. The Developer shall (i) retain all of its Books and Records until the end of the Term and (ii) retain all of its books, records and documents it produces or receives (if any) regarding the Project for five years following the end of the Term. If any provision of this Agreement specifies any longer time period for retention of particular records, such time period will prevail.

16.2 Audits. In addition to any other specific audit rights that ADOT may have under this Agreement, ADOT will have such rights to review and audit the Books and Records, as ADOT deems necessary for the purposes of verifying compliance with this Agreement, applicable Law, Governmental Approvals, and NEPA Approval[s].

16.3 Arizona Public Records Act and Freedom of Information

16.3.1 The Developer acknowledges and agrees that all records, documents, drawings, plans, specifications and other materials in ADOT's possession, including materials submitted by the Developer, are subject to the provisions of the Public Records Act. To the extent that this Agreement involves the exchange or creation of "public information," as such term is defined by the Public Records Act, that ADOT collects, assembles, or maintains or has a right of access to, and is not otherwise excepted from disclosure under the Public Records Act, the Developer is

required, at its sole cost and expense, to make any such information available in .pdf format, which is accessible by the public.

16.3.2 If the Developer believes information or materials submitted to ADOT constitute trade secrets or confidential commercial, financial or proprietary information or other information that is exempted from disclosure under the Public Records Act, the Developer shall specifically and conspicuously do all of the following:

- (a) invoke the exclusion on submission of the information or other material for which protection is sought;
- (b) identify the data or other materials for which protection is sought with conspicuous labeling as “CONFIDENTIAL” in the center header of each such page affected;
- (c) state the reasons why protection is necessary; and
- (d) fully comply with any applicable state Law with respect to information that the Respondent contends should be exempt from disclosure.

16.3.3 If ADOT receives a request for public disclosure of materials marked “CONFIDENTIAL,” ADOT will use reasonable efforts to notify the Developer of the request and give the Developer an opportunity to assert, in writing and at the Developer’s sole expense, a claimed exception under the Public Records Act or other applicable Law within the time period specified in the notice issued by ADOT and allowed under A.R.S. § 39-171. Under no circumstances, however, will ADOT be responsible or liable to the Developer or any other Person for the disclosure of any such labeled materials, whether the disclosure is required by Law, or court order, or occurs through inadvertence, mistake or negligence on the part of ADOT or its officers, employees, contractors or consultants.

16.3.4 In the event of any proceeding or litigation concerning the disclosure of any material submitted by the Developer to ADOT, ADOT’s sole involvement will be as a stakeholder retaining the material until otherwise ordered by a court or such other authority having jurisdiction with respect thereto, and the Developer shall be fully responsible for otherwise prosecuting or defending any action concerning the materials at its sole cost and risk; provided, however, that ADOT reserves the right, in its sole discretion, to intervene or participate in the litigation in such manner as it deems necessary or desirable. Except in the case of ADOT’s voluntary intervention or participation in litigation, the Developer shall pay and reimburse ADOT within 30 days after receipt of demand and reasonable supporting documentation for all costs and fees, including attorneys’ fees and costs, ADOT incurs in connection with any litigation, proceeding or request for disclosure.

16.3.5 Nothing contained in this Section 16.3 (Arizona Public Records Act and Freedom of Information) will modify or amend requirements and obligations imposed on ADOT by the Public Records Act or other applicable Law, and the

provisions of the Public Records Act or other Laws will control in the event of a conflict between the procedures described above and the applicable Law.

16.3.6 The Developer further acknowledges and agrees that all Submittals, records, documents, drawings, plans, specifications, and other materials in FHWA's possession may also be subject to disclosure under federal law, including the Freedom of Information Act. The Developer's rights and obligations with respect to such disclosure shall be in accordance with such federal law.

ARTICLE 17. CONSEQUENTIAL DAMAGES

17.1 No Consequential Damages. Except as otherwise expressly provided in this Agreement, and to the fullest extent permissible under applicable Law, neither Party will have the right to claim damages, including punitive and incidental damages, against the other Party for breach of this Agreement, in tort or on any other basis whatsoever, to the extent that any loss claimed by either Party is for loss of profits, loss of use, loss of production, loss of business, loss of business opportunity or any claim for consequential loss or for indirect loss of any nature.

17.2 Exclusions. The Parties agree that the limitation in Section 17.1 (No Consequential Damages) will not apply to or limit ADOT's right to recover from the Developer:

17.2.1 any Losses (excluding defense costs) to the extent that they are either covered by the proceeds of insurance carried by a Developer-Related Entity or are required to be insured against pursuant to ARTICLE 11 (Insurance);

17.2.2 Losses arising out of fraud, criminal conduct, intentional misconduct, recklessness or bad faith on the part of a Developer-Related Entity;

17.2.3 amounts payable by the Developer to ADOT under an indemnity set out in this Agreement;

17.2.4 any Performance Deductions;

17.2.5 any Termination Sum; or

17.2.6 interest, late charges, fees, transaction fees and charges, penalties, and similar charges that this Agreement expressly states are due from the Developer.

ARTICLE 18. MISCELLANEOUS PROVISIONS

18.1 Amendments. The Contract Documents may be amended only by a written instrument duly executed by the Parties or their respective successors or assigns, except to the extent expressly provided otherwise in this Agreement.

18.2 Waiver.

18.2.1 No waiver of any term, covenant or condition of the Contract Documents shall be valid unless in writing and signed by the obligee Party.

18.2.2 The exercise by a Party of any right or remedy provided under the Contract Documents shall not waive or preclude any other or further exercise thereof or the exercise of any other right or remedy. No waiver by any Party of any right or remedy under the Contract Documents shall be deemed to be a waiver of any other or subsequent right or remedy under the Contract Documents. The consent by one Party to any act by the other Party requiring such consent shall not be deemed to render unnecessary the obtaining of consent to any subsequent act for which consent is required, regardless of whether similar to the act for which consent is given.

18.2.3 Except as provided otherwise in the Contract Documents, no act, delay or omission done, suffered or permitted by one Party or its agents shall be deemed to waive, exhaust or impair any right, remedy or power of such Party hereunder, or to relieve the other Party from the full performance of its obligations under the Contract Documents.

18.2.4 Either Party's waiver of any breach or failure to enforce any of the terms, covenants, conditions or other provisions of the Contract Documents at any time shall not in any way limit or waive that Party's right thereafter to enforce or compel strict compliance with every term, covenant, condition or other provision. Furthermore, if the Parties make and implement any interpretation of the Contract Documents without documenting such interpretation by an instrument signed by both Parties, such interpretation and implementation thereof will not be binding in the event of any future claims or disputes.

18.3 Independent Contractor.

18.3.1 The Developer is an independent contractor, and nothing contained in the Contract Documents shall be construed as constituting any relationship with ADOT other than that of Project developer and independent contractor.

18.3.2 Nothing in the Contract Documents is intended or shall be construed to create any partnership, joint venture or similar relationship between ADOT and the Developer; and in no event shall either Party take a position in any tax return or other writing of any kind that a partnership, joint venture or similar relationship exists. While the term "public-private partnership" may be used on occasion to refer to

contractual relationships of the type hereby created, the Parties do not thereby express any intention to form or hold themselves out as a de jure or de facto partnership, joint venture or similar relationship, to share net profits or net losses, or to give ADOT control or joint control over the Developer's financial decisions or discretionary actions concerning the Project and the Work.

18.3.3 In no event shall the relationship between ADOT and the Developer be construed as creating any relationship whatsoever between ADOT and the Developer's employees. Neither the Developer nor any of its employees is or shall be deemed to be an employee of ADOT. Except as otherwise specified in the Contract Documents, the Developer has sole authority and responsibility to employ, discharge and otherwise control its employees and has complete and sole responsibility as a principal for its agents, for all Subcontractors and for all other Persons that the Developer or any Subcontractor hires to perform or assist in performing the Work.

18.4 Successors and Assigns; Change of Control.

18.4.1 The Contract Documents shall be binding upon and inure to the benefit of ADOT and the Developer and their respective permitted successors, assigns and legal representatives.

18.4.2 The Developer shall not assign, transfer, pledge, mortgage or otherwise encumber any of its rights or obligations under the Contract Documents without the written consent of ADOT, which consent may be granted or withheld in ADOT's discretion.

18.4.3 ADOT may, without the Developer's consent, assign all or any portion of its rights, title, and interests in and to this Agreement, the ADOT License and the Performance Security (if applicable) to any other Governmental Entity that succeeds to the governmental powers and authority of ADOT.

18.4.4 In the event of ADOT's assignment of all of its rights, title and interests in the Contract Documents as permitted hereunder, the Developer shall have no further recourse to ADOT under the Contract Documents or otherwise except as specifically provided by other contractual agreement or by statute.

18.4.5 The Developer shall not voluntarily or involuntarily cause, permit or suffer any Change of Control without ADOT's prior approval. If there occurs any voluntary or involuntary Change of Control without ADOT's prior approval, ADOT, at its option, may declare it to be a material Developer Default.

18.4.6 Where ADOT's prior approval is required for a proposed sale, assignment, conveyance, transfer, pledge, mortgage, encumbrance, sublease or grant of right of entry, license or other special occupancy, or for any proposed Change of Control, ADOT may withhold or condition its approval in its discretion.

18.4.7 Assignments and transfers of the Developer's interest in or to the Contract Documents approved by ADOT will be effective only upon ADOT's receipt of notice of the assignment or transfer and a written recordable instrument executed by the transferee, in form and substance acceptable to ADOT, in which the transferee, without condition or reservation, assumes all of the Developer's obligations, duties and liabilities under this Agreement and the other Contract Documents then in effect and agrees to perform and observe all provisions thereof applicable to the Developer. Each transferee shall take the Developer's interest in or to the Contract Documents subject to, and shall be bound by, the Subcontracts, the Governmental Approvals, the NEPA Approval[s] and all agreements between the transferor and Governmental Entities with jurisdiction over the Project or the Work, except to the extent otherwise approved by ADOT in its reasonable discretion.

18.5 Change of Organization or Name.

18.5.1 The Developer shall not change its legal form of business organization without the prior approval of ADOT, which consent may be granted or withheld in ADOT's discretion.

18.5.2 In the event either Party changes its name, such Party agrees to promptly furnish the other Party with notice of change of name and appropriate supporting documentation and take necessary steps to ensure the new name replaces the old name in all Contract Documents.

18.6 Designation of Representatives; Cooperation with Representatives.

18.6.1 ADOT and the Developer shall each designate an individual or individuals with the authority to make decisions and bind the Parties on matters relating to the Contract Documents (for each Party, its respective "**Authorized Representative**"). Exhibit 11 (Authorized Representatives) hereto provides the Parties' initial Authorized Representative designations. Either Party may change its initial Authorized Representative designation by a subsequent writing delivered to the other Party in accordance with Section 18.11 (Notices and Communications).

18.6.2 The Developer shall cooperate with ADOT and all representatives of ADOT designated as described above.

18.7 Limitation on Third Party Beneficiaries. It is not intended by any of the provisions of the Contract Documents to create any third-party beneficiary hereunder or to authorize anyone not a Party hereto to commence any legal proceeding of any nature whatsoever based on the terms or provisions hereof, except to the extent that specific provisions (such as the indemnity provisions) identify third parties and state that they are entitled to benefits hereunder. Except as otherwise provided in this Section 18.7 (Limitation on Third Party Beneficiaries), the duties, obligations and responsibilities of the Parties to the Contract Documents with respect to third parties shall remain as imposed by Law. The Contract Documents shall not be construed to create a

contractual relationship of any kind between ADOT and a Subcontractor or any Person other than Developer.

18.8 No Personal Liability of ADOT Employees; Limitation on State's Liability.

18.8.1 ADOT's Authorized Representatives are acting solely as agents and representatives of ADOT when carrying out the provisions of or exercising the power or authority granted to them. They shall not be liable to any Developer-Related Entity either personally or as employees of ADOT for actions in their ordinary course of employment.

18.8.2 In no event shall ADOT be liable for any injury, damage or death caused by any Developer Act.

18.8.3 Nothing in the Agreement waives or diminishes the protections and defense afforded to ADOT and its employees by A.R.S. Title 12, Chapter 7, Article 2 (§ 12-820 *et seq.*).

18.8.4 The Developer shall not seek injunctive or other equitable relief to delay, prevent or otherwise hinder ADOT or any jurisdiction from developing, constructing or maintaining any facility that was planned and that would or might impact the revenue that the Developer would or might derive from any Project Site.

18.9 Governing Law; Jurisdiction.

18.9.1 The Contract Documents shall be governed by and construed in accordance with (a) the Laws of the State, without regard to its principles of conflicts of laws, and (b) any applicable federal Laws.

18.9.2 The Parties agree to use arbitration, after exhausting applicable administrative reviews, to resolve disputes arising out of this Agreement where the sole relief sought is monetary damages of \$500,000 or less, exclusive of interest and costs. The arbitration shall be submitted under the relevant rules of the American Arbitration Association in effect as of the date of the demand for arbitration. The matter disputed shall be submitted to an arbitrator mutually selected by the Developer and ADOT.

18.9.3 All litigation between the Parties pertaining to this Agreement or their breach shall be filed, heard and decided in the Superior Court located in Maricopa County, Arizona, which shall have exclusive jurisdiction and venue. Each Party shall bear its own attorneys' fees and expenses incurred in connection with any litigation hereunder, regardless of the outcome.

18.10 Israel Boycott and Forced Labor of Ethnic Uyghurs.

18.10.1 Pursuant to A.R.S. § 35-393.01, the Developer hereby certifies that it is not currently engaged in, and agrees to not engage in, throughout the Term, a boycott of goods or services from Israel.

18.10.2 Pursuant to A.R.S. § 35-394, the Developer hereby certifies that it does not currently use, and agrees to not use, throughout the Term, the forced labor or any goods or services produced by the forced labor of ethnic Uyghurs in the People’s Republic of China.

18.11 Notices and Communications

18.11.1 Notices under the Contract Documents shall be in writing and: (a) delivered personally; (b) sent by certified mail, return receipt requested; (c) sent by a recognized overnight mail or courier service, with delivery receipt requested; or (d) sent by email communication followed by a hard copy and with receipt confirmed by telephone, to the addresses set forth in Sections 18.11.2 and 18.11.3, as applicable (or to such other address as may from time to time be specified in writing).

18.11.2 All notices, correspondence and other communications to the Developer must be delivered to the following address or as otherwise directed by the Developer’s Authorized Representative:

[]
[Title]
[Street Address]
[City, State Zip]
Telephone:
E-mail:
Facsimile:

In addition, copies of all notices regarding disputes, suspension, termination and default must be delivered to the following:

[]
[Title]
[Street Address]
[City, State Zip]
Telephone:
E-mail:
Facsimile:

18.11.3 All notices, correspondence and other communications to ADOT will be marked as regarding the Arizona NEVI Deployment Program: Phase 1 –

Interstates NEVI Zone ¹⁶ and shall be delivered to the following address or as otherwise directed by ADOT's Authorized Representative:

Arizona Department of Transportation
Attn: Emily Christ
206 S. 17th Avenue, MD139A
Phoenix, AZ 85007
Telephone: (602) 712-7682
E-mail: echrist@azdot.gov

In addition, copies of all notices regarding disputes, suspension, termination and default must be delivered to the following:

Office of the Arizona Attorney General
Transportation Section
2005 N. Central Avenue
Phoenix, AZ 85004
Telephone: (602) 542-1680
E-mail: transportation@azag.gov
Facsimile: (602) 542-3646

18.11.4 Notices shall be deemed received when actually received in the office of the addressee (or by the addressee if personally delivered) or when delivery is refused, as shown on the receipt of the U.S. Postal Service, private carrier or other Person making the delivery. Notices delivered by email communication shall be deemed received when actual receipt at the email address of the addressee is confirmed. Notwithstanding the foregoing, notices sent or received after 5:00 p.m. shall be deemed received on the first Business Day following delivery.

18.12 Taxes. The Developer is solely responsible for the payment of taxes accrued or arising out of the performance of its obligations pursuant to this Agreement.

18.13 Integration of Contract Documents. ADOT and Developer agree and expressly intend that, subject to Section 18.14 (Severability), this Agreement and other Contract Documents constitute a single, non-severable, integrated agreement the terms of which are interdependent and non-divisible.

18.14 Severability

18.14.1 If any clause, provision, section or part of the Contract Documents is ruled invalid by a court of competent jurisdiction, then the Parties shall:

(a) promptly meet and negotiate a substitute for such clause, provision, section or part that shall, to the greatest extent legally permissible, effect the

¹⁶ **NOTE TO PROPOSERS:** This will be populated with applicable NEVI Zone numbers for all Project Sites.

original intent of the Parties to account for any change in the Work resulting from such invalidated portion; and

(b) if necessary or desirable, apply to the court or other decision maker (as applicable) that declared such invalidity for an interpretation of the invalidated portion to guide the negotiations.

18.14.2 The invalidity or unenforceability of any such clause, provision, section or part shall not affect the validity or enforceability of the balance of the Contract Documents, which shall be construed and enforced as if the Contract Documents did not contain such invalid or unenforceable clause, provision, section or part.

18.15 Headings. The captions of the sections and clauses herein are inserted solely for convenience and under no circumstances are they or any of them to be treated or construed as part of this Agreement.

18.16 Entire Agreement. The Contract Documents contain the entire understanding of the Parties with respect to the subject matter hereof and supersede all prior agreements, understandings, statements, representations and negotiations between the Parties with respect to its subject matter.

18.17 Counterparts. This instrument may be executed in two or more counterparts, each of which shall be deemed an original, but all of which together shall constitute one and the same instrument.

[THE REMAINDER OF THE PAGE IS INTENTIONALLY BLANK]

IN WITNESS WHEREOF, this Agreement has been executed as of the date first set forth above.

[DEVELOPER]

**ARIZONA DEPARTMENT OF
TRANSPORTATION**

By: _____

By: _____

Name: _____

Name: _____

Title: _____

Title: _____

EXHIBIT 1

ACRONYMS AND DEFINITIONS

Unless otherwise specified, wherever the abbreviations or defined terms included in this Exhibit 1 (*Acronyms and Definitions*) are used in the Agreement, they shall have the meanings set forth below.

ADA	Americans with Disabilities Act, 42 U.S.C. § 12101 et seq.
ADOT	Arizona Department of Transportation
AFC	Alternative Fuel Corridor
A.R.S.	Arizona Revised Statutes
API	Application Programming Interface
BIL	Bipartisan Infrastructure Law
CE	Categorical Exclusion
CFR	Code of Federal Regulations
CCS	Combined Charging System
D&C	Design and Construction
DCFC	Direct Current Fast Charger
EEO	Equal Employment Opportunity
EV	Electric Vehicle
EV-ChART	Electric Vehicle Charging Analytics and Reporting Tool
EVITP	Electric Vehicle Infrastructure Training Program
EVSE	Electric Vehicle Supply Equipment
FHWA	U.S. Department of Transportation, Federal Highway Administration
ITP	Instructions to Proposers
NEC	National Electric Code
NEPA	National Environmental Policy Act
NEVI	National Electric Vehicle Infrastructure
NFPA	National Fire Protection Association
NIST	National Institute of Standards and Technology
NTP	Notice to Proceed
O&M	Operations and Maintenance
OCPI	Open Charge Point Interface
OCPP	Open Charge Point Protocol
P3	Public-Private Partnership
PCIDSS	Payment Card Industry Data Security Standard
PDF	Portable Document Format
RFP	Request for Proposals
RIDs	Reference Information Documents
U.S.	United States
U.S.C.	United States Code
USDOT	United States Department of Transportation

“**Abandon**” means to abandon all or a material part of the Project, which abandonment will be deemed to have occurred if:

- (a) the Developer demonstrates through statements, acts or omissions an intent to not continue (for any reason other than a Relief Event that materially interferes with its ability to continue) to design, construct, operate or maintain all or a material part of the Project; or
- (b) no significant Work (taking into account the Project Schedule, if applicable, and any Relief Event) on the Project is performed for a continuous period of more than 60 days.

“**ADA**” means the Americans with Disabilities Act of 1990 (42 U.S.C. § 12101), as amended from time to time.

“**ADOT**” means the Arizona Department of Transportation, a public agency constituted under the laws of the State.

“**ADOT License**” means the license between ADOT and the Developer, in the form set out in Exhibit 8 (Form of ADOT License), dated on or about the Effective Date.

“**ADOT Standards and Requirements**” means all state standards and requirements applicable to the Project under Exhibit 2 (Technical Requirements), Part B (ADOT Standards and Requirements).

“**Agreement**” means this agreement (including all its Exhibits), as amended from time to time.

“**Alternative Fuel Corridor**” or “**AFC**” shall have the meaning given to such term in 23 CFR 680.

“**Annual Data Submittal**” is defined in Section 7.1.1(c) (Data Reporting).

“**Annual O&M Amount**” means the applicable amount as is set forth in Exhibit 3 (Developer’s Proposal Commitments), Part D (Annual O&M Amount).

“**Authorized Representative**” is defined in Section 18.6.1 (Designation of Representatives; Cooperation with Representatives) of the Agreement.

“**Books and Records**” means any and all documents, books, records, papers, letters/correspondence, maps, plans, tapes, photographs, exhibits, computer- or other electronic-based, -stored, or -generated information, or other information or materials, whether prepared and maintained or received, of the Developer or any Developer-Related Entity relating to the Project, including:

- (a) all design and construction documents, and all operations and maintenance documents (including Submittals, Subcontracts, invoices, schedules, meeting minutes, budgets, forecasts and change orders);
- (b) all budgets, certificates, claims, correspondence, data, data fields, documents, analyses (including expert analyses), facts, files, investigations, notices, plans, projections, proposals, records, reports, requests, samples, schedules, settlements, statements, studies, surveys, tests, test results, vehicular traffic information analyzed, categorized, characterized, created, collected, generated, maintained, processed, produced, prepared, provided, recorded, stored or used by the Developer or any Developer-Related Entity in connection with the Project;
- (c) any other sketches, charts, calculations, drawings, layouts, depictions, specifications, manuals, electronic files, artwork, and other documents, information, materials, or other work product created or collected under the terms of, or otherwise under this Agreement;
- (d) any other “Books and Records” or words of similar effect as specifically required or identified under any applicable Law, Governmental Approval or NEPA Approval; and
- (e) any of the foregoing that disclose or embody Intellectual Property.

“**Business Day**” means any day except Saturdays, Sundays and the legal holidays as defined in A.R.S § 1-301.

“**Calendar Quarter**” means each three-month period ending on March 31, June 30, September 30 and December 31, or, if applicable, those periods less than three months at the beginning and end of the O&M Period.

“**Change of Control**” means any assignment, sale, financing, grant of security interest, transfer of interest or other transaction of any type or description, including by or through voting securities, asset transfer, contract, merger, acquisition, succession, dissolution, liquidation or otherwise, that results, directly or indirectly, in a change in possession of the power to direct or control or cause the direction or control of the management of the Developer or a material aspect of its business. A Change of Control of a shareholder, member, partner or joint venture member of the Developer may constitute a Change of Control of the Developer if such shareholder, member, partner or joint venture member possesses the power to direct or control, or cause the direction or control of, the management of the Developer. Notwithstanding the foregoing, the following shall not constitute a Change of Control:

- (a) A change in possession of the power to direct or control the management of the Developer or a material aspect of its business due solely to a bona fide transaction involving beneficial interests in the ultimate parent organization of a shareholder, member, partner or joint venture member of the Developer, (but not if the shareholder, member, partner or joint venture member is the ultimate

parent organization), unless the transferee in such transaction is at the time of the transaction suspended or debarred or subject to a proceeding to suspend or debar from bidding, proposing or contracting with any federal or State department or agency;

- (b) An upstream reorganization or transfer of direct or indirect interests in the Developer so long as there occurs no change in the entity with ultimate power to direct or control or cause the direction or control of the management of the Developer;
- (c) A transfer of interests between managed funds that are under common ownership or control other than a change in the management or control of a fund that manages or controls the Developer;
- (d) The exercise of minority veto or voting rights (whether provided by Law, by the Developer's organizational documents or by related member or shareholder agreements or similar agreements) over major business decisions of the Developer, provided that if such minority veto or voting rights are provided by shareholder or similar agreements, ADOT has received copies of such agreements; or
- (e) The voluntary resignation of a shareholder, member, partner or joint venture member of Developer during the O&M Period, but only if (i) the resigning shareholder, member, partner or joint venture member has not been in control of the management of the Developer at any time prior thereto, and (ii) the resignation occurs following expiration of the statutory period of repose under A.R.S. § 12-552.

“Charger” shall have the meaning given to such term in 23 CFR 680.

“Charging Network” shall have the meaning given to such term in 23 CFR 680.

“Charging Network Provider” shall have the meaning given to such term in 23 CFR 680.

“Charging Port” shall have the meaning given to such term in 23 CFR 680.

“Charging Station” shall have the meaning given to such term in 23 CFR 680.

“Combined Charging System” or **“CCS”** shall have the meaning given to such term in 23 CFR 680.

“Connector” shall have the meaning given to such term in 23 CFR 680.

“Construction Work” means all Work and activities (including associated administrative work) necessary to build or construct, reconstruct, rehabilitate, make, form, manufacture, furnish, install, integrate, supply, deliver or equip the Project.

“Contactless Payment Methods” shall have the meaning given to such term in 23 CFR 680.

“Contract Documents” means the documents listed in Section 1.2.1 of the Agreement.

“Cryptographic Agility” shall have the meaning given to such term in 23 CFR 680.

“Cybersecurity Specifications” means the ADOT EV Charging Infrastructure Cybersecurity Specifications set forth in Exhibit 2-4 (ADOT EV Charging Infrastructure Cybersecurity Specifications) to the ADOT Standards and Requirements.

“Cybersecurity Plan” means the plan provided by the Developer addressing the charging infrastructure virtual security and protection including data transmission, storage, and any integrated connections documenting all potential risks and mitigation actions through the Term in accordance with Section 7(a) (Cybersecurity Plan) of the ADOT Standards and Requirements.

“D&C Payment Bond” means the bond referred to in Section 12.1.2 (D&C Payment Bond) of the Agreement in the form of Exhibit 7, Part B.

“D&C Performance Bond” means the bond referred to in Section 12.1.1 (D&C Performance Bond) of the Agreement in the form of Exhibit 7, Part A.

“D&C Period” means the period commencing on the Effective Date and ending on the Services Commencement Date.

“D&C Period Progress Report” means each report to be delivered by the Developer in accordance with Section 5.2 (D&C Period Reporting) complying with the requirements of Exhibit 5 (Performance Reports), Part A (D&C Period Progress Report).

“D&C Relief Event” means:

- (a) any utility interconnection delays caused by a Utility Owner past the date for “Power Utility Service Connection” specified in row 4 of the Project Schedule;
- (b) any Force Majeure Event; and
- (c) natural disasters, including:
 - (i) any flood (as “flood” is defined in 44 CFR 59.1);
 - (ii) any fire, explosion or earthquakes; and
 - (iii) any hurricane, tornado or named windstorm and ensuing storm surges;

except, in each case, to the extent attributable to any Developer Act.

“D&C Work” means the Design Work and the Construction Work.

“Data Interface Control Document” means the document describing the technical details for satisfying all data interface requirements based on the specifications, including all data submission requirements outlined in Section 8(c) (*Data Interface Control Document (ICD) Requirements*) of the ADOT Standards and Requirements.

“day” means a calendar day.

“Debarment Regulations” means:

- (a) Federal Executive Order no. 12549 (February 18, 1986);
- (b) Federal Executive Order no. 12689 (August 16, 1989);
- (c) 31 U.S.C. § 6101 note (Section 2455, Pub. L. 103-355, 108 Stat. 3327); and
- (d) 49 CFR Part 29 “Government-wide Debarment and Suspension (Nonprocurement).”

“Design Documents” means all drawings (including plans, profiles, cross-sections, notes, elevations, sections, details and diagrams), specifications, reports, studies, calculations, electronic files, records and submittals necessary for, or related to, the design of the Project in accordance with the Contract Documents, the Governmental Approvals, the NEPA Approval[s] and applicable Law.

“Design Work” means all Work related to the design, redesign, engineering or architecture for the Project.

“Developer” means [●].

“Developer Act” means any negligence, gross negligence, recklessness, fraud, criminal conduct, illegal activity, intentional misconduct, bad faith, fault, breach of contract, breach of the requirements of the Contract Documents, violation of Law, a Governmental Approval or a NEPA Approval, or other wrongful act or wrongful omission of, or by, any Developer-Related Entity.

“Developer Commitment” means the proposal and commitments made by the Developer, as set out in Exhibit 3 (*Developer’s Proposal Commitments*).

“Developer Default” is defined in Section 14.1 (*Developer Default*).

“Developer Default Notice” is defined in Section 14.2.1 (*Notice and Cure Periods*).

“Developer Key Cycle Date” means the dates on which ADOT will make payments owing from ADOT to Developer under this Agreement. Such payment dates occur on the third Wednesday of each month and are published by ADOT annually.

“Developer-Related Entity” means:

- (a) the Developer;
- (b) any Subcontractor;
- (c) any other Persons performing any of the Work for or on behalf of the Developer;
- (d) any other Persons for whom the Developer may be legally or contractually responsible; and
- (e) the employees, officers, directors, agents, representatives, consultants, successors and assigns of any of the foregoing.

“Developer Required Insurance” is defined in Section 11.1 (Insurance Policies).

“Direct Current Fast Charger” or **“DCFC”** shall have the meaning given to such term in 23 CFR 680.

“Distributed Energy Resource” shall have the meaning given to such term in 23 CFR 680.

“Early Termination” means (a) the termination of this Agreement in its entirety or (b) the termination of this Agreement with respect to a Project Site, as applicable, for any reason prior to the Expiry Date.

“Early Termination Date” means [, with respect to this Agreement in its entirety or each with respect to a Project Site, as applicable,] the effective date of Early Termination, as specified in Section 14.3 (Termination for Developer Default).

“Effective Date” means the date on which this Agreement is executed by both Parties and on or prior to which each of the Effective Date Conditions Precedent have been satisfied or otherwise waived in accordance with Section 2.3 (Conditions Precedent to Effective Date).

“Effective Date Conditions Precedent” is defined in Section 2.3 (Conditions Precedent to Effective Date).

“Electric Vehicle” or **“EV”** shall have the meaning given to such term in 23 CFR 680.

“Electric Vehicle Infrastructure Training Program” or **“EVITP”** shall have the meaning given to such term in 23 CFR 680.

“Electric Vehicle Supply Equipment” or **“EVSE”** shall have the meaning given to such term in 23 CFR 680.

“Eligible Costs” means, subject to Section 8.5 (Reimbursement Principle):

- (i) costs for site preparation, permitting, and design;
- (ii) costs to purchase, construct/install, integrate, test, and implement Charging Stations;
- (iii) construction costs directly related to a Charging Station;
- (iv) costs to acquire and install on-site electric service equipment (e.g., power meter, transformer, switch gear);
- (v) Minor Utility Upgrades;
- (vi) costs of charger hardware;
- (vii) costs of charger software;
- (viii) costs to repair, upgrade, and/or replace existing chargers to meet NEVI Formula Program's minimum standards and requirements;
- (ix) costs to meet Americans with Disabilities Act of 1990 (ADA) requirements;
- (x) costs to purchase proprietary adapters;
- (xi) costs to install signage at site;
- (xii) costs for site amenities necessary to satisfy the NEVI Formula Programs minimum standards and requirements, such as lighting;
- (xiii) costs for workforce development activities, such as Electric Vehicle Infrastructure Training Program (EVITP) certification;
- (xiv) costs for property lease;
- (xv) the following amenities so long as such amenities otherwise meet NEVI Formula Program's minimum standards and requirements:
 - a. sun and rain-proof canopies;
 - b. costs for planning, permitting, acquisition, and installation of on-site distributed energy resource equipment (e.g., solar arrays, stationary batteries);
 - c. additional DCFC Chargers;
 - d. pull-through parking;
 - e. up-sized electrical equipment (i.e., additional make-readies); and

- f. North American Charging Standard (NACS) connectors;
- (xvi) fixed operating and maintenance costs up to five years after the Charging Station is commissioned, such as:
 - a. charger lease fees, in the case the Developer opts to lease rather than purchase charging equipment;
 - b. cellular network fees, internet service fees, or other similar fees necessary to provide communications between EV Charging Stations and charging network providers; and
 - c. other operation and maintenance costs that are paid in advance through a contract for networking, data sharing, and warranty purposes.

Eligible Costs do not include, for the avoidance of doubt, any Ineligible Costs.

“**EV-ChART**” is defined in Exhibit 2-3 (Data Requirements) to the ADOT Standards and Requirements.

“**EV-ChART Data Format and Preparation Guidance**” is defined in Exhibit 2-3 (Data Requirements) to the ADOT Standards and Requirements.

“**Expiration Option A**” is defined in Section 4.3.2(a)(i) (Project Site Expiry Date Obligations).

“**Expiration Option B**” is defined in Section 4.3.2(a)(ii) (Project Site Expiry Date Obligations).

“**Expiry Date**” means the date five years following the Services Commencement Date [for the final Charging Station to achieve Services Commencement hereunder].

“**Force Majeure Event**” means the occurrence of any of the following events after the date of this Agreement that directly causes either Party to be unable to comply with all or a material part of its obligations under this Agreement:

- (a) war, civil war, invasion, violent act of foreign enemy or armed conflict;
- (b) nuclear, chemical or biological contamination, or ionizing radiation, unless the source or cause of the contamination is brought to or near the Project Site by the Developer or a Developer-Related Entity, or is a result of any breach by the Developer of the terms of this Agreement; or
- (c) an act of Terrorism.

“**Full-Time**” means to dedicate no less than the greatest of 40 hours per week, those times/dates and durations required under this Agreement, and otherwise the full

amount of time necessary for the proper performance of assigned responsibilities, in each case, on the Project Site.

“Full-Time On-Call” means Full-Time and accessible to ADOT 24-hours per day, seven days per week, but not necessarily on the Project Site. If located off the Project Site, then available to be on the Project Site within 45 minutes of notification by ADOT.

“Good Industry Practice” means the exercise of the degree of skill, diligence, prudence and foresight that would reasonably and ordinarily be expected from a skilled and experienced designer, engineer, constructor, maintenance contractor, operator or developer seeking in good faith to comply with its contractual obligations, complying with all applicable Laws, Governmental Approvals, and NEPA Approval[s], using accepted design, construction, operation, maintenance, and repair standards and criteria normally used on similar projects in the State, and engaged in the same type of undertaking in the United States under similar circumstances and conditions, similar to those within the same geographic area as the Project.

“Governmental Approval” means all approvals, permits, permissions, consents, licenses, certificates (including sales tax exemption certificates) and authorizations (whether statutory or otherwise) that are required from time to time in connection with the Project to be issued by ADOT or any Governmental Entity. “Governmental Approval” excludes the NEPA Approval.

“Governmental Entity” means any federal, state, local or foreign government (including local jurisdictions) and any political subdivision or any governmental, quasi-governmental, judicial, public or statutory instrumentality, administrative agency, authority, body or entity. “Governmental Entity” includes ADOT when acting in the capacity of issuing an Environmental Approval, but not otherwise.

“Guidelines” is defined in Recital (D).

“Host Site Agreement” means the agreement for [description of property interest] in respect of the Project Site between the Host Site Owner and the Developer, dated [●].]

“Host Site Owner” means, for an applicable Project Site, the owner of such Project Site and counterparty to the Host Site Agreement.]

“HSA Key Terms” means, for each applicable Project Site:

- (a) an acknowledgement by the Host Site Owner of the Developer’s obligation to comply with the NEVI Federal Standards and Requirements.
- (b) a prohibition on the Host Site Owner continuing Electric Vehicle charging operations at the Project Site following early termination of the Host Site Agreement unless the Host Site Owner (or a substitute developer) has entered into an agreement with ADOT including the obligation to comply with the NEVI

Federal Standards and Requirements until the end of the Term of this Agreement.

- (c) in the event that the Developer elects Expiration Option B, or in an Early Termination scenario where there is no replacement developer, the requirement for the Developer to perform certain minimum decommissioning requirements that are equal to or greater than those required by Section 13(b) (*Decommissioning Activities*) of the ADOT Standards and Requirements.
- (d) a restriction on the Developer assigning the Host Site Agreement, unless there is ADOT agreement to an assignment under this Agreement; and
- (e) unless otherwise provided pursuant to a separate legal instrument, the grant by the Host Site Owner of the legal authority for the Developer to grant ADOT the ADOT License.

“Indemnified Parties” means ADOT, the State, the Arizona State Transportation Board, and for each of the foregoing, its successors, assigns, officeholders, officers, directors, agents, representatives, consultants and employees.

“Ineligible Costs” means any costs that are not Eligible Costs, including:

- (a) costs incurred prior to the Effective Date;
- (b) any final design and construction costs incurred prior to NEPA approval;
- (c) any costs not directly related to a Charging Station;
- (d) Major Utility Upgrades;
- (e) costs covered by utility providers or other parties;
- (f) purchase of real estate;
- (g) construction or general maintenance of building and parking facilities if not directly related to a Charging Station;
- (h) variable operating and maintenance costs, including costs for electricity and demand charges, insurance, and other recurrent business costs such as staffing;
- (i) fixed operations or maintenance costs incurred outside of an up-front contract at or near time of Charging Station commissioning;
- (j) operations and maintenance costs for chargers beyond the four required network-connected DCFC ports;
- (k) costs for studies or research;

- (l) taxes, permits, business expenses (travel, licenses, etc.), lobbying expenses, and funding received from other incentive or grant programs including those provided by utilities; and
- (xiii) any amenities not otherwise captured in subsections (xii) and (xv) of the definition of Eligible Costs.

“Insolvency Event” means, in respect of any Person:

- (a) any involuntary case is commenced seeking, at any time during the case, liquidation, company reorganization, restructuring, controlled management, suspension of payments, scheme of arrangement, appointment of provisional liquidator, custodian, receiver or administrative receiver, notification, resolution or petition for winding up, writ of attachment, execution or similar process, or similar proceeding, under any applicable Law, in any jurisdiction, including bankruptcy or insolvency Law, and such case has not been dismissed or stayed within 60 days;
- (b) any voluntary case is commenced seeking, at any time during the case liquidation, company reorganization, restructuring, controlled management, suspension of payments, scheme of arrangement, appointment of provisional liquidator, custodian, receiver or administrative receiver, notification, resolution, or petition for winding up, writ of attachment, execution or similar process, or similar proceeding, under any applicable Law, in any jurisdiction, including bankruptcy or insolvency Law;
- (c) in any voluntary or involuntary case described in clauses (a) and (b) above, the Agreement or any other Contract Document is rejected, including rejection pursuant to 11 U.S.C. § 365 or any successor statute; or
- (d) any inability on the part of that Person to pay its debts as they fall due.

“Instructions to Proposers” or **“ITP”** means the instructions to proposers included in the RFP, containing directions for the preparation and submittal of information by the Proposers in response to the RFP.

“Intellectual Property” means any and all patents, trademarks, service marks, copyright, database rights, moral rights, rights in a design, know-how, confidential information and all or any other intellectual or industrial property rights whether or not registered or capable of registration and whether subsisting in the United States or any other part of the world together with all or any goodwill relating or attached thereto which is created, brought into existence, acquired, used or intended to be used by the Developer or any Developer-Related Entity for the purposes of carrying out the Work or otherwise for the purposes of this Agreement.

“Key Personnel” means each of the positions listed in the Key Personnel Requirements.

“Key Personnel Requirements” means Exhibit 2-1 (Key Personnel Requirements) to the ADOT Standards and Requirements.

“Loss” or **“Losses”** means any loss, damage, injury, liability, obligation, cost, response cost, expense (including attorneys’, accountants’ and expert witnesses’ fees and expenses (including those incurred in connection with the enforcement of any indemnity or other provision of this Agreement)), fee, charge, judgment, penalty or fine. Losses include injury to or death of Persons, damage or loss of property, and harm or damage to natural resources.

“Law” means: (a) any law, statute, code, regulation, ordinance, rule or common law; (b) any binding judgment; (c) any binding judicial, administrative or executive order or decree; (d) any written directive, guideline, policy requirement or other governmental restriction (including those resulting from the initiative or referendum process, but excluding those by ADOT within the scope of its administration of the Contract Documents); or (e) any similar form of decision of or determination by, or any written interpretation or administration of any of the foregoing by, any Governmental Entity, in each case that is applicable to or has an impact on the Project or the Work, whether taking effect before or after the Effective Date, including Environmental Laws. The term “Laws” includes the NEVI Federal Standards and Requirements and any FHWA guidance in respect of the NEVI Federal Standards and Requirements and any form of decision, determination, interpretation or administration made by FHWA in respect thereof. The term “Laws”, however, excludes Governmental Approvals and the NEPA Approval[s].

“Major Utility Upgrade” means upgrades to the electrical utility grid with an aggregate cost of over \$250,000, including, but not limited to, longer line extension or upgrades, improvements to offsite power generation, bulk power transmission, or substations covered by the utility. Instances also include those where utility poles or transformers are within a distance only accessible by longer line extensions to the Project Site and Developer needs network upgrades and build-out by electrical utility provider to connect to the distribution utility. The cost of Major Utility Upgrades is an Ineligible Cost.

“Minimum Quarterly Uptime Requirement” means the ninety-seven percent (97%) minimum EVSE uptime requirement for each Calendar Quarter, calculated in accordance with Section 9(a) (Minimum Quarterly Uptime) of the ADOT Standards and Requirements.

“Minor Utility Upgrade” means upgrades to the electrical utility with an aggregate cost of under \$250,000 including those to acquire, install or upgrade on-site electric service equipment including power meter, transformer, and switch gear provided that the work is necessitated solely by the construction or upgrading of the Project Site. Work also includes upgrades necessary to connect a charging station to the electric grid distribution network including, but not limited to, extending power lines or upgrading

existing power lines. Instances also include where an existing utility pole and transformer is located adjacent to the Project Site or an existing point of connection already exists on the Project Site and Developer requires additional switchgear or lines to connect to the grid. The cost of Minor Utility Upgrades is an Eligible Cost.

“**NEPA**” means The National Environmental Policy Act, 42 U.S.C. § 4321 et seq., as amended and as it may be amended from time to time.

“**NEPA Approval**” means, [for each Project Site], the ADOT provided and agency approved NEPA document, as may be modified by any supplements and re-evaluations pertaining to the Project.

“**NEVI Formula Program**” is defined in Recital (A).

“**NEVI Federal Rule**” means 23 CFR 680, as updated and amended from time to time, which establishes regulations setting minimum standards and requirements for projects funded under the NEVI Formula Program, as restated in Exhibit 2 (Technical Requirements), Part A (NEVI Federal Standards and Requirements).

“**NEVI Federal Standards and Requirements**” means the provisions of the NEVI Federal Rule, and all federal statutory requirements applicable to the Project, as updated and amended from time to time.

“**NEVI Federal Uptime Requirement**” means the ninety-seven percent (97%) minimum EVSE uptime requirement, calculated in accordance with the NEVI Federal Rule (23 CFR 680.116(b)) and as set out in Section 6(b) (Minimum Uptime) of the NEVI Federal Standards and Requirements.

“**NEVI Zone [insert number]**” is defined in the RFP.

“**Noncompliance Event**” means each event identified as a “Noncompliance Event” in Exhibit 4 (Performance Deductions).

“**Noncompliance Event Start Date**” means for any Noncompliance Event, the earlier of the date that:

- (a) ADOT first obtains knowledge of the Noncompliance Event; or
- (b) the Developer should have reasonably known of the occurrence of the Noncompliance Event.

“**Notice**” means a written notice, notification, correspondence, order or other communication given under the Agreement to a Party that complies with the prescriptions set forth in Section 18.11 (Notices and Communications) of the Agreement.

“**Notice to Proceed**” means either NTP (Design and Materials) or NTP (Construction).

“**NTP (Construction)**” is defined in Section 2.5(a) (Notice to Proceed (Construction)).

“**NTP (Construction) Conditions Precedent**” is defined in Section 2.5(a) (Notice to Proceed (Construction)).

“**NTP (Design and Materials)**” is defined in Section 2.4.1(a) (Notice to Proceed (Design and Materials)).

“**O&M Payment**” is defined in Section 8.2.1(a).

“**O&M Payment Amount**” is defined in Section 8.2.1.

“**O&M Payment Invoice**” is defined in Section 8.2.2.

“**O&M Performance Requirements**” means the minimum performance requirements for the O&M Work set out in the Technical Requirements.

“**O&M Performance Security**” is defined in Section 12.2.1 (Performance Security during O&M Period).

“**O&M Period**” means[, with respect to each Project Site,] the period commencing on the Services Commencement Date [of the applicable Project Site] and ending five years from the Services Commencement Date [for such Project Site].

“**O&M Relief Event**” means:

- (a) any Force Majeure Event;
- (b) any excusable events related to the NEVI Federal Uptime Requirement covered by the NEVI Federal Standards and Requirements, including the following under 23 CFR 680.116(b):
 - (i) electric utility interruption;
 - (ii) failure to charge or meet the EV charging customer’s expectation for power delivery due to the fault of the vehicle;
 - (iii) scheduled maintenance;
 - (iv) vandalism; and
 - (v) natural disasters, including:
 - (A) any flood (as “flood” is defined in 44 CFR 59.1);
 - (B) any fire, explosion or earthquakes; and

- (C) any hurricane, tornado or named windstorm and ensuing storm surges;

except, in each case, to the extent attributable to any Developer Act.

“O&M Work” means the operation and use, and ongoing routine, preventative and emergency maintenance of the Project during the O&M Period.

“O&M Year” means[, with respect to each Project Site,] the one year period commencing on the Services Commencement Date [of the applicable Project Site] and ending on the anniversary thereof throughout the O&M Period. The O&M Period [for an applicable Project Site] shall be comprised of five O&M Years.

“One-time Data Submittal” is defined in Section 7.1.1 (Data Reporting).

“Open Charge Point Interface” or **“OCPI”** shall have the meaning given to such term in 23 CFR 680.

“Open Charge Point Protocol” or **“OCPP”** shall have the meaning given to such term in 23 CFR 680.

“P3 Law” is defined in Recital (C).

“Party” means ADOT or the Developer, as the context may require, and **“Parties”** means ADOT and the Developer, collectively.

“Performance Deductions” means performance deductions calculated in accordance with Exhibit 4 (Performance Deductions).

“Performance Security” means, during the D&C Period, the D&C Performance Bond and the D&C Payment Bond, and during the O&M Period, the O&M Performance Security.

“Persistent Developer Default” means, unless in dispute under the terms of the Agreement, failure by the Developer to achieve eighty percent (80%) minimum EVSE uptime (calculated in accordance with Section 9(a) (Minimum Quarterly Uptime) of the ADOT Standards and Requirements) in three consecutive Calendar Quarters.

“Person” means any individual, corporation, joint venture, limited liability company, company, voluntary association, general or limited partnership, trust, unincorporated organization or Governmental Entity.

“Plan” is defined in Recital (A).

“Plug and Charge” shall have the meaning given to such term in 23 CFR 680.

“Power Sharing” shall have the meaning given to such term in 23 CFR 680.

“Prohibited Person” means any Person who is:

- (a) debarred, suspended, proposed for debarment with a final determination still pending, declared ineligible or voluntarily excluded (as such terms are defined in any of the Debarment Regulations) from participating in procurement or nonprocurement transactions with the federal government or any department, agency or instrumentality of the federal government pursuant to any of the Debarment Regulations;
- (b) indicted, convicted or had a civil or administrative judgment rendered against such Person for any of the offenses listed in any of the Debarment Regulations and no event has occurred and no condition exists that is likely to result in the debarment or suspension of such Person from contracting with the federal government or any department, agency or instrumentality of the federal government;
- (c) listed on the “Lists of Parties Excluded from Federal Procurement and Nonprocurement Programs” issued by the U.S. General Services Administration;
- (d) located within, or doing business or operating from, a country or other territory subject to a general embargo administered by the United States Office of Foreign Assets Control (“**OFAC**”);
- (e) designated on the OFAC list of “Specially Designated Nationals”;
- (f) otherwise targeted under economic or financial sanctions administered by the United Nations, OFAC or any other U.S. federal economic sanctions authority or any divestment or sanctions program of the State;
- (g) a banking institution chartered or licensed in a jurisdiction against which the United States Secretary of the Treasury has imposed special measures under Section 311 of the USA PATRIOT Act (“**Section 311**”);
- (h) located within or is operating from a jurisdiction that has been designated as noncooperative with international anti-money laundering principles by the Financial Action Task Force on Money Laundering;
- (i) a financial institution against which the United States Secretary of the Treasury has imposed special measures under Section 311; or
- (j) a senior foreign political figure or a prohibited foreign shell bank within the meaning of 31 CFR 103.175.

“Project” is defined in Recital (B).

“Project Bond” means any of D&C Performance Bond, D&C Payment Bond, and the O&M Performance Security (if provided in the form of a bond) provided in accordance with the Agreement.

“Project Payment Cap” means \$[●].¹⁷

“Project Schedule” means the Developer’s plan to complete performance of the D&C Work, as is set forth in Exhibit 3 (Developer’s Proposal Commitments), Part B (Project Schedule).

“Project Schedule of Values” or **“Project SOV”** means the Developer’s baseline schedule of values submitted with the Proposal, as is set forth in Exhibit 3 (Developer’s Proposal Commitments), Part C (Project Schedule of Values).

“Project Site” is defined in Recital (B).

“Project Site Layout” the detailed plan sets, diagrams, maps, or schematic plans provided by the Developer in accordance with Section 2(a) (Prior to NTP (Construction)) of the ADOT Standards and Requirements.

“Proposal Due Date” is defined in the ITP.

“Proposal Schedule” means the schedule provided in response to Part C of ITP Form 2.

“Public Records Act” means A.R.S., Title 39, Chapter 1, Article 2.

“Quarterly Data Submittal” is defined in Section 7.1.1(b) (Data and Cybersecurity Reporting).

“Quarterly Performance Report” means each quarterly report to be delivered by the Developer in accordance with Section 9.6 (Quarterly Performance Reporting) in the form of and complying with the requirements of Exhibit 5 (Performance Reports), Part B (Quarterly Performance Report).

“Reference Information Documents” or **“RIDs”** means those documents listed in Volume III (Reference Information Documents) to the RFP. The Reference Information Documents are not part of Contract Documents and were provided to the Developer for informational purposes only and without representation or warranty by ADOT.

“Relief Event” means any D&C Relief Event or any O&M Relief Event, as applicable in the circumstances.

¹⁷ **NOTE TO PROPOSERS:** Project Payment Cap will be equal to the lesser of (i) \$800,000, and (ii) the total requested federal share reflected in Line 6 of ITP Form 6-1 (Price Summary) submitted by the Developer. This definition will be expanded to include Project Payment Cap for each applicable Project Site in the event that a single Project Agreement governs multiple Project Sites.

“Relief Event Notice” is defined in Section 10.2.2 (Notice and Information).

“Request for Proposals” or **“RFP”** is defined in Recital (D).

“Remedial Plan” is defined in Section 9.4 (Remedial Plan).

“Secure Payment Method” shall have the meaning given to such term in 23 CFR 680.

“Services Commencement” means the satisfaction of the Services Commencement Conditions.

“Services Commencement Certificate” is defined in Section 5.3.1 (Services Commencement).

“Services Commencement Conditions” is defined in Section 5.3.2 (Services Commencement).

“Services Commencement Date” means the date on which written certification that the Developer has achieved Services Commencement is issued in accordance with Section 5.3.2 (Services Commencement).

“Services Commencement Deadline” means the “Services Commencement Deadline” specified in the Project Schedule, as such date may be extended in accordance with this Agreement following any D&C Relief Events.

“Services Commencement Payment Invoice” is defined in Section 8.1.2.

“Services Commencement Long Stop Date” means the day that is 365 days after the Services Commencement Deadline, as such period may be extended in accordance with the terms of this Agreement.

“Services Commencement Payment” is defined in Section 8.1.1(a).

“Services Commencement Payment Amount” is defined in Section 8.1.1.

“Services Commencement Retainage” is defined in Section 8.1.1(b).

“Smart Charge Management” shall have the meaning given to such term in 23 CFR 680.

“State” means the State of Arizona.

“Subcontract” means any agreement by the Developer with any other Person to perform any part of the Work or provide any materials, equipment or supplies for any part of the Work, or any such agreement, supplement, or amendment at a lower tier, between a Subcontractor and its lower tier Subcontractor or a supplier and its lower tier supplier, at all tiers.

“Subcontractor” means any Person with whom the Developer has entered into any Contract to perform any part of the Work or provide any materials, equipment or supplies for the Project, on behalf of the Developer, and any other Person with whom any Subcontractor has further subcontracted any part of the Work, at all tiers.

“Submittal” means any document, work product or other written or electronic product or item required under the Agreement to be delivered or submitted to ADOT for approval, review, comment or otherwise. “Submittal” does not include any of the One-time Data Submittal, Quarterly Data Submittal or Annual Data Submittal.

“Surety” means each properly licensed surety company, insurance company or other Person approved by ADOT, which has issued any Project Bond.

“Technical Requirements” means the technical requirements set out in Exhibit 2 (Technical Requirements), Part A (NEVI Federal Standards and Requirements) and Exhibit 2 (Technical Requirements), Part B (ADOT Standards and Requirements).

“Term” is defined in Section 2.1 (Term).

“Termination Date” means:

- (a) the Expiry Date; or
- (b) if applicable, with respect to those Project Sites that are terminated hereunder pursuant to ARTICLE 14 (Developer Default), the Early Termination Date.

“Termination Sum” means, in respect of any Early Termination of this Agreement during:

- (a) the D&C Period, the amount calculated in accordance with Section 14.4.1 (Compensation on Termination); or
- (b) the O&M Period, the amount calculated in accordance with Section 14.4.2 (Compensation on Termination).

“Terrorism” means activities against Persons or property of any nature:

- (a) that involve the following or preparation for the following:
 - (i) use or threat of force or violence; or
 - (ii) commission or threat of an act that interferes with or disrupts an electronic, communication, information or mechanical system; and
- (b) when one or both of the following applies:

- (i) it appears that the intent is to intimidate or coerce ADOT, a Governmental Entity or the civilian population or any segment of the civilian population, or to disrupt any segment of the economy;
 - (ii) it appears that the intent is to intimidate or coerce ADOT or a Governmental Entity, or to further political, ideological, religious, social or economic objectives or to express (or express opposition to) a philosophy or ideology; and
- (c) that are criminally defined as terrorism for purposes of State, federal or international applicable Law.

“Third-Party Claim” means any claim, dispute, disagreement, cause of action, demand, suit, action, investigation or administrative proceeding brought by a Person that is not an Indemnified Party or the Developer with respect to Losses sustained or incurred by such Person (including in relation to any damage caused during the performance of the Work), in respect of matters for which the Developer is responsible under the Agreement. Third-Party Claim shall include any Indemnified Party’s employee, agent or contractor who asserts a claim against an Indemnified Party that is within the scope of the indemnities and that is not covered by the Indemnified Party’s worker’s compensation program.

“Third-Party Data Sharing” is defined in Section 7.1.2 (Data Reporting).

“UL” means Underwriters Lab or Underwriters Laboratories.

“Utility Owner” means any utility company identified as relevant to the Project.

“Work” means the D&C Work and the O&M Work, and all other work, services and obligations required to be furnished, performed, and provided by the Developer under this Agreement.

EXHIBIT 2
TECHNICAL REQUIREMENTS
(Attached)

Part A: NEVI Federal Standards and Requirements

The Developer acknowledges that this Part A of Exhibit 2 is a restatement of the standards and requirements of the NEVI Federal Rule, and has been updated for implementation of the Agreement. Nothing in this Part A of Exhibit 2 shall override the obligation of the Developer to comply with the NEVI Federal Standards and Requirements.

Section No. (23 CFR Ref)	Section Title	Sub No.	Sub Title	Requirements
1. (§ 680.106)	Installation, operation, and maintenance by qualified technicians of Electric Vehicle charging infrastructure	(b)	Number of Charging Ports	Direct Current Fast Chargers (DCFCs) located along and designed to serve users of designated Alternative Fuel Corridors (AFCs), charging stations must have at least four network-connected DCFC Charging Ports and be capable of simultaneously charging at least four Electric Vehicles (EVs).
		(c)	Connector Type	All charging Connectors must meet applicable industry standards. Each DCFC Charging Port must be capable of charging any combined charging system (CCS)-compliant vehicle and each DCFC Charging Port must have at least one permanently attached CCS Type 1 Connector.
		(d)	Power Level	DCFC Charging Ports must support output voltages between 250 volts DC and 920 volts DC. DCFCs located along and designed to serve users of designated AFCs must have a continuous power delivery rating of at least 150 kilowatt (kW) and supply power according to an EV's power delivery request up to 150 kW, simultaneously from each Charging Port at a charging station. These corridor-serving DCFC charging stations may conduct Power Sharing so long as each Charging Port continues to meet an EV's request for power up to 150 kW.
		(e)	Availability	Charging stations located along and designed to serve users of designated AFCs must be available for use and sited at locations physically accessible to the public 24 hours per day, 7 days per week, year-round. This section does not prohibit isolated or temporary interruptions in service or access because of maintenance or repairs or due to the exclusions outlined in Section 6(b)(3) (Minimum Uptime) of the NEVI Federal Standards and Requirements or the Agreement.
		(f)	Payment Methods	Unless charging is permanently provided free of charge to customers, charging stations must: (1) Provide for Secure Payment Methods, accessible to persons with disabilities, which at a minimum shall include a Contactless Payment Method that accepts major debit and credit cards, and either an automated toll-free phone number or a short message/messaging system (SMS) that provides the EV charging customer with the option to initiate a charging session and submit payment;

Section No. (23 CFR Ref)	Section Title	Sub No.	Sub Title	Requirements
				<p>(2) Not require a membership for use;</p> <p>(3) Not delay, limit, or curtail power flow to vehicles on the basis of payment method or membership; and</p> <p>(4) Provide access for users that are limited English proficient and accessibility for people with disabilities. Automated toll-free phone numbers and SMS payment options must clearly identify payment access for these populations.</p>
		(g)	Equipment Certification	All DCFC chargers shall be certified by an Occupational Safety and Health Administration Nationally Recognized Testing Laboratory and all chargers should be certified to the appropriate Underwriters Laboratories (UL) standards for electric vehicle supply equipment (EVSE).
		(h)	Security	<p>The Developer shall implement physical and cybersecurity strategies consistent with the Arizona Electric Vehicle Infrastructure Deployment Plan to ensure charging station operations protect consumer data and protect against the risk of harm to, or disruption of, EV charging infrastructure and the grid.</p> <p>(1) Physical security strategies may include lighting; siting and station design to ensure visibility from onlookers; driver and vehicle safety; video surveillance; emergency call boxes; fire prevention; charger locks; and strategies to prevent tampering and illegal surveillance of payment devices.</p> <p>(2) Cybersecurity strategies may include the following topics: user identity and access management; Cryptographic Agility and support of multiple public key infrastructures (PKIs); monitoring and detection; incident prevention and handling; configuration, vulnerability, and software update management; third-party cybersecurity testing and certification; and continuity of operation when communication between the charger and Charging Network is disrupted.</p> <p>Refer to Section 7 (Security) of the ADOT Standards and Requirements for additional requirements.</p>
		(i)	Long-Term Stewardship	Developer must ensure that chargers are maintained and operational in compliance with the Federal Rule for the Term, being a period of not less than five years from the Services Commencement Date.
		(j)	Qualified Technician	All workforce installing, maintaining, and operating chargers shall have appropriate licenses, certifications, and training to ensure that the installation and maintenance of chargers is performed safely by a qualified and increasingly diverse workforce of licensed technicians and other laborers. Further

Section No. (23 CFR Ref)	Section Title	Sub No.	Sub Title	Requirements
				<p>(1) Except as provided in paragraph (j)(2) of this section, all electricians installing, operating, or maintaining EVSE must meet one of the following requirements:</p> <ul style="list-style-type: none"> i. Certification from the Electric Vehicle Infrastructure Training Program (EVITP); ii. Graduation or a continuing education certificate from a registered apprenticeship program for electricians that includes charger-specific training and is developed as a part of a national guideline standard approved by the U.S. Department of Labor in consultation with the U.S. Department of Transportation. <p>(2) For projects requiring more than one electrician, at least one electrician must meet the requirements above, and at least one electrician must be enrolled in an electrical registered apprenticeship program.</p> <p>(3) All other onsite, nonelectrical workers directly involved in the installation, operation, and maintenance of chargers must have graduated from a registered apprenticeship program or have appropriate licenses, certifications, and training as required by the State.</p>
		(k)	Customer Service	Developer must ensure that EV charging customers have mechanisms to report outages, malfunctions, and other issues with charging infrastructure. The Developer must enable access to accessible platforms that provide multilingual services. Developer must comply with the American with Disabilities Act of 1990 requirements and multilingual access when creating reporting mechanisms.
		(l)	Customer Data Privacy	The Developer must collect, process, and retain only that personal information strictly necessary to provide the charging service to a consumer, including information to complete the charging transaction and to provide the location of charging stations to the consumer. Chargers and Charging Networks should be compliant with appropriate Payment Card Industry Data Security Standards (PCIDSS) for the processing, transmission, and storage of cardholder data. The Developer must also take reasonable measures to safeguard consumer data.
		(m)	Use of Program Income	<p>(1) Any net income from revenue from the sale, use, lease, or lease renewal of real property acquired shall be used for Title 23, United States Code, eligible projects.</p> <p>(2) For purposes of program income or revenue earned from the operation of the Project, the Developer should ensure that all revenues received from</p>

Section No. (23 CFR Ref)	Section Title	Sub No.	Sub Title	Requirements
				<p>operation of the Project are used only for:</p> <ul style="list-style-type: none"> i. Debt service with respect to the Project, including funding of reasonable reserves and debt service on refinancing; ii. A reasonable return on investment of any private person financing the Project, as determined by the State or the Developer; iii. Any costs necessary for the improvement and proper operation and maintenance of the Project, including reconstruction, resurfacing, restoration, and rehabilitation; iv. If the Project is subject to a public-private partnership agreement, payments that the party holding the right to the revenues owes to the other party under the public-private partnership agreement; and v. Any other purpose for which Federal funds may be obligated under Title 23, United States Code.
2. (§ 680.108)	Interoperability of Electric Vehicle charging infrastructure	(a)	Charger-to-EV Communication	Chargers must conform to ISO 15118-3 and must have hardware capable of implementing both ISO 15118-2 and ISO 15118-20. Charger software must conform to ISO 15118-2 and be capable of Plug and Charge. Conformance testing for charger software and hardware should follow ISO 15118-4 and ISO 15118-5, respectively.
		(b)	Charger-to-Charger -Network Communication	Chargers must conform to Open Charge Point Protocol (OCPP) 2.0.1 or higher.
		(c)	Charging-Network-to-Charging-Network Communication	Charging Networks must be capable of communicating with other Charging Networks in accordance with Open Charge Point Interface (OCPI) 2.2.1.
		(d)	Network Switching Capability	Chargers must be designed to securely switch Charging Network Providers without any changes to hardware.
3. (§ 680.110)	Traffic control devices or on-premises signs acquired, installed, or operated	(a)	Manual on Uniform Traffic Control Devices for Streets and Highways	All traffic control devices must comply with 23 CFR 655 (Traffic Operations).
		(b)	On-Premises Signs	On-property or on-premise advertising signs must comply with 23 CFR 650 (Highway Beautification). Refer to <u>Section 3(d) (Signage, Marking, Striping)</u> of the ADOT Standards and Requirements for additional requirements.
4.	Data Submittal	(a)	Quarterly Data	The Developer must ensure the following data are submitted on a quarterly basis in

Section No. (23 CFR Ref)	Section Title	Sub No.	Sub Title	Requirements
§ 680.112)			Submittal	<p>a manner prescribed by FHWA. Any quarterly data provided to ADOT or made public shall be aggregated and anonymized to protect confidential business information.</p> <ol style="list-style-type: none"> (1) Charging station identifier that the following data can be associated with. This must be the same charging station name or identifier used to identify the charging station in data made available to third parties in <u>Section 6(c)(1) (Third-Party Data Sharing)</u> of the NEVI Federal Standards and Requirements; (2) Charging Port identifier. This must be the same Charging Port identifier used to identify the Charging Port in data made available to third parties in <u>Section 6(c)(8)(ii) (Third-Party Data Sharing)</u> of the NEVI Federal Standards and Requirements; (3) Charging session start time, end time, and any error codes associated with an unsuccessful charging session by port; (4) Energy (kWh) dispensed to EVs per charging session by port; (5) Peak session power (kW) by port; (6) Payment method associated with each charging session; (7) Charging station port uptime, T_outage, and T_excluded calculated in accordance with the equation in <u>Section 6(b) (Minimum Uptime)</u> of the NEVI Federal Standards and Requirements for each of the previous three months; (8) Duration (minutes) of each outage.
		(b)	Annual Data Submittal	<p>Developer must ensure the following data are submitted on an annual basis, on or before March 1, in a manner prescribed by FHWA. Any annual data provided to ADOT or made public shall be aggregated and anonymized to protect confidential business information.</p> <ol style="list-style-type: none"> (1) Maintenance and repair cost per charging station for the previous year. (2) For private entities identified in Section 4(c) (One-time Data Submittal) of the NEVI Federal Standards and Requirements, identification of and participation in any State or local business opportunity certification programs including but not limited to minority-owned businesses, Veteran-owned businesses, woman-owned businesses, and businesses owned by economically

Section No. (23 CFR Ref)	Section Title	Sub No.	Sub Title	Requirements
				<p>disadvantaged individuals.</p> <p>This section applies only to both the NEVI Formula Program projects and grants awarded under 23 U.S.C. § 151(f) for projects that are for EV charging stations located along and designed to serve the users of designated AFCs. Developer must ensure the following data are collected and submitted once for each Project Site, on or before March 1 of each year, in a manner prescribed by FHWA. Any one-time data provided to ADOT or made public shall be aggregated and anonymized to protect confidential business information.</p> <ol style="list-style-type: none"> (1) The name and address of the private entity(ies) involved in the operation and maintenance of chargers. (2) Distributed Energy Resource installed capacity, in kW or kWh as appropriate, of asset by type (e.g., stationary battery, solar) per charging station; (3) Charging station real property acquisition cost, charging equipment acquisition and installation cost, and distributed energy resource acquisition and installation cost; and (4) Aggregate grid connection and upgrade costs paid to the electric utility as part of the project, separated into: <ol style="list-style-type: none"> i. Total distribution and system costs, such as extensions to overhead/underground lines, and upgrades from single-phase to three-phase lines; and ii. Total service costs, such as the cost of including poles, transformers, meters, and on-service connection equipment.
5. (§ 680.114)	Charging Network connectivity of Electric Vehicle charging infrastructure	(a)	Charger-to-Charger -Network Communication	<ol style="list-style-type: none"> (1) Chargers must communicate with a Charging Network via a secure communication method. See Section 2 (Interoperability of Electric Vehicle charging infrastructure) of the NEVI Federal Standards and Requirements for more information about OCPP requirements. (2) Chargers must have the ability to receive and implement secure, remote software updates and conduct real-time protocol translation, encryption and decryption, authentication, and authorization in their communication with Charging Networks. (3) Charging Networks must perform and chargers must support remote charger monitoring, diagnostics, control, and smart charge management.

Section No. (23 CFR Ref)	Section Title	Sub No.	Sub Title	Requirements
				(4) Chargers and Charging Networks must securely measure, communicate, store, and report energy and power dispensed, real-time charging-port status, real-time price to the customer, and historical charging-port uptime.
		(b)	Interoperability	See Section 2 (Interoperability of Electric Vehicle charging infrastructure) of the NEVI Federal Standards and Requirements for interoperability requirements.
		(c)	Charging-Network-to-Charging-Network Communication	A Charging Network must be capable of communicating with other Charging Networks to enable an EV driver to use a single method of identification to charge at Charging Stations that are a part of multiple Charging Networks. See Section 2 (Interoperability of Electric Vehicle charging infrastructure) of the NEVI Federal Standards and Requirements for more information about OCPI requirements.
		(d)	Charging-Network-to-Grid Communication	Charging Networks must be capable of secure communication with electric utilities, other energy providers, or local energy management systems.
		(e)	Disrupted Network Connectivity	Chargers must remain functional if communication with the charging network is temporarily disrupted, such that they initiate and complete charging sessions, providing the minimum required power level defined in Section 1(d) (Power Level) of the NEVI Federal Standards and Requirements.
6. (§ 680.116)	Information on EV Charging Infrastructure locations, pricing, real time availability, and accessibility through mapping	(a)	Communication of Price	<p>(1) The price for charging must be displayed prior to initiating a charging transaction and be based on the price for electricity to charge in \$/kWh.</p> <p>(2) The price for charging displayed and communicated via the Charging Network must be the real-time price (i.e., price at that moment in time). The price at the start of the session cannot change during the session.</p> <p>(3) Price structure including any other fees in addition to the price for electricity to charge must be clearly displayed and explained.</p>
		(b)	Minimum Uptime	<p>Each Charging Port shall have an average annual uptime of greater than 97%, subject to the following requirements:</p> <p>(1) A Charging Port is considered “up” when its hardware and software are both online and available for use, or in use, and the Charging Port successfully dispenses electricity in accordance with requirements for minimum power level (see Section 1(d) (Power Level) of the NEVI Federal Standards and Requirements).</p> <p>(2) Charging Port uptime must be calculated on a monthly basis for the previous 12 months.</p> <p>(3) Charging Port uptime percentage must be calculated using the following</p>

Section No. (23 CFR Ref)	Section Title	Sub No.	Sub Title	Requirements
				<p>equation: $\mu = ((525,600 - (\text{Outage} - \text{Excluded})) / 525,600) \times 100$ where: μ = port uptime percentage; Outage = total minutes of outage in the preceding 12 months; and Excluded = total minutes of outage in the preceding 12 months caused by the following reasons outside the Developer's control, provided that the Developer can demonstrate that the Charging Port would otherwise be operational: electric utility service interruptions, failure to charge or meet the EV charging customer's expectation for power delivery due to the fault of the vehicle, scheduled maintenance, vandalism, or natural disasters.</p>
		(c)	Third-Party Data Sharing	<p>The following data fields shall be made available, free of charge, to third-party software developers, via application programming interface (API):</p> <ol style="list-style-type: none"> (1) Unique charging station name or identifier; (2) Address (street address, city, State, and zip code) of the property where the charging station is located; (3) Geographic coordinates in decimal degrees of exact charging station location; (4) Developer name; (5) Charging Network Provider name; (6) Charging station status (operational, under construction, planned, or decommissioned); (7) Charging station access information: <ol style="list-style-type: none"> i. Charging station access type (public or limited to commercial vehicles); ii. Charging station access days/times (hours of operation for the charging station); (8) Charging Port information: <ol style="list-style-type: none"> i. Number of Charging Ports;

Section No. (23 CFR Ref)	Section Title	Sub No.	Sub Title	Requirements
				<ul style="list-style-type: none"> ii. Unique port identifier; iii. Connector types available by port; iv. Charging level by port (DCFC, AC Level 2, etc.); v. Power delivery rating in kilowatts by port; vi. Accessibility by vehicle with trailer (pull-through stall) by port (yes/no); vii. Real-time status by port in terms defined by OCPI 2.2.1; <p>(9) Pricing and payment information:</p> <ul style="list-style-type: none"> i. Pricing structure; ii. Real-time price to charge at each Charging Port, in terms defined by OCPI 2.2.1; and iii. Payment methods accepted at charging station.
7. (§ 680.118)	Other Federal Requirements			<p>All applicable federal statutory and regulatory requirements apply to the Project. These requirements include, but are not limited to:</p> <p>(a) All statutory and regulatory requirements that are applicable to funds apportioned under chapter 1 of Title 23, U.S.C., and the requirements of 2 CFR Part 200 apply. This includes the applicable requirements of 23, U.S.C., and Title 23, CFR, such as the applicable Buy America requirements at 23 U.S.C. § 313 and Buy America, Buy America Act (Pub. L. No 117-58, div. G sections 70901-70927).</p> <p>(b) As provided at 23 U.S.C. § 109(s)(2), projects to install EV chargers are treated as if the project is located on a Federal-aid highway. As a project located on a Federal-aid highway, 23 U.S.C. § 113 applies and Davis Bacon Federal wage rate requirements included at subchapter IV of chapter 31 of Title 40, U.S.C., must be paid for any project funded with NEVI Formula Program funds.</p> <p>(c) The Americans with Disabilities Act of 1990 (ADA), and implementing regulations, apply to EV charging stations by prohibiting discrimination on the basis of disability by public and private entities. EV charging stations must comply with applicable accessibility standards adopted by the Department of Transportation into its ADA regulations (49 CFR Part 37) in 2006, and adopted by the Department of Justice into its ADA regulations (28 CFR Parts 35 and 36) in 2010.</p> <p>(d) Title VI of the Civil Rights Act of 1964, and implementing regulations, apply to</p>

Section No. (23 CFR Ref)	Section Title	Sub No.	Sub Title	Requirements
				<p>this program to ensure that no person shall, on the grounds of race, color, or national origin, be excluded from participation in, be denied the benefits of, or be subjected to discrimination under any program or activity receiving Federal financial assistance.</p> <p>(e) All applicable requirements of Title VIII of the Civil Rights Act of 1968 (Fair Housing Act), and implementing regulations, apply to this program.</p> <p>(f) Reserved.</p> <p>(g) The Uniform Relocation Assistance and Real Property Acquisition Act, and implementing regulations, apply to this program by establishing minimum standards for federally funded programs and projects that involve the acquisition of real property (real estate) or the displacement or relocation of persons from their homes, businesses, or farms.</p> <p>(h) The National Environmental Policy Act of 1969 (NEPA), the Council on Environmental Quality's NEPA implementing regulations, and applicable agency NEPA procedures apply to this program by establishing procedural requirements to ensure that federal agencies consider the consequences of their proposed actions on the human environment and inform the public about their decision making for major federal actions significantly affecting the quality of the human environment.</p>

Part B: ADOT Standards and Requirements

Section No.	Section Title	Sub No.	Sub Title	Requirements
1.	General Requirements	(a)	Standards	<ul style="list-style-type: none"> • The following standards shall apply to the Work: • American Association of State Highway and Transportation Officials (AASHTO) Roadway Lighting Design Guide • Arizona Department of Transportation 2021 Standard Specifications for Road and Bridge Construction • Federal Risk and Authorization Management Program, PS-3, SA-9 (4), and SA-9 (5) • International Organization for Standardization (ISO) 15118-2: Road vehicles — Vehicle-to-Grid Communication Interface — Part 2: Network and application protocol requirements • ISO 15118-3: Road vehicles — Vehicle to grid communication interface — Part 3: Physical and data link layer requirements • ISO 15118-4: Road vehicles — Vehicle to grid communication interface — Part 4: Network and application protocol conformance test • ISO 15118-5: Road vehicles — Vehicle to grid communication interface — Part 5: Physical layer and data link layer conformance test • National Electrical Safety Code ANSI C2 (NESC) • National Fire Protection Association (NFPA) 70® (National Electrical Code) • National Institute of Standards and Technology (NIST) SP 800-63 Digital Identity Guidelines • NIST Cybersecurity Framework

Section No.	Section Title	Sub No.	Sub Title	Requirements
				<ul style="list-style-type: none"> • NIST SP 800-175 A Guideline for Using Cryptographic Standards • NIST SP 800-175 B Guideline for Using Cryptographic Standards • NIST SP 800-94 Guide to Intrusion Detection and Prevention Systems (IDPS) • NIST SP 800-92 Guide to Computer Security Log Management • NIST SP 800-40 Guide to Enterprise Patch Management • NIST SP 800-61 Computer Security Incident Handling Guide • NIST SP-800-161 Supply Chain Risk Management Practices for Federal Information Systems and Organizations • NIST SP-800-53 Security and Privacy Controls for Information Systems and Organizations • Open Charge Point Protocol (OCPP) 2.0.1 • Payment Card Industry Data Security Standard (PCIDSS) • Underwriters Lab (UL) - Standard 2231
2.	Project Management, Reporting, and Submittals	(a)	Prior to NTP (Construction)	<p>As a condition to NTP (Construction), the Developer shall submit to ADOT for review, comment, or acceptance, as applicable the following list of Submittals, which shall remain in effect until the Services Commencement Date:</p> <ul style="list-style-type: none"> • Organizational Chart: An organization chart of all the members of the Developer organization along with contact names, phone numbers, and email addresses of all individuals involved in design, permitting, EVSE procurement, installation, and construction of the Project. • Project Schedule: An updated Project Schedule, outlining any updates to the major activities and their associated

Section No.	Section Title	Sub No.	Sub Title	Requirements
				<p>timeframes from the Proposal. No update shall be made to the Services Commencement Deadline other than for D&C Relief Events (if any).</p> <ul style="list-style-type: none"> • Existing Site Documentation: A series of videos and/or photographs of the existing elements of the site and surrounding area that can be used to determine the condition, size, material, location, and other pertinent information. • Project Site Layout: A detailed plan sets using a diagram, map, or schematic showing locations of the following items and any additional items useful for understanding the Project Site Layout: <ul style="list-style-type: none"> ○ all existing buildings, structures, amenities, ○ existing and proposed designated charging parking spaces, ○ EVSE, ○ electric service distribution lines and utility connection build-out to the Project Site, ○ utility connection equipment (power meter, transformer, switch gear, etc.), ○ signage, marking, striping, ○ vehicle and pedestrian points of access, ○ space (if any) available for future use, ○ Americans with Disabilities Act (ADA) access, ○ lighting and security features; and ○ all other planned and/or proposed amenities. • Equipment Specifications: Detailed manufacturer and/or supplier equipment specifications, manuals, or guides for the EVSE.
		(b)	Prior to Services Commencement	As a condition to achieving Services Commencement, the Developer shall submit to ADOT for review, comment, or

Section No.	Section Title	Sub No.	Sub Title	Requirements
				<p>acceptance, as applicable the following list of Submittals, which shall remain in effect during the Term:</p> <ul style="list-style-type: none"> • Utility Owner Certification: Provide Utility Owner’s certification or commissioning report indicating that all electrical systems and components are properly installed and that the Project Site has the power capacity to operate per requirements outlined in Sections 1(d) (Power Level) of the NEVI Federal Standards and Requirements. • Cybersecurity Plan: Provide a narrative describing the Developer’s method for satisfying all cybersecurity requirements outlined in Section 7(a) (Cybersecurity Plan) of the ADOT Standards and Requirements. • Data Interface Control Document (ICD): Provide a Data ICD describing the technical details for satisfying all data interface requirements based on the specifications, including all data submission requirements outlined in Sections 4 (Data Submittal), 5 (Charging Network connectivity of Electric Vehicle charging infrastructure) and 6 (Information on EV Charging Infrastructure locations, pricing, real time availability, and accessibility through mapping) of the NEVI Federal Standards and Requirements and Section 8(c) (Data Interface Control Document (ICD) Requirements) of the ADOT Standards and Requirements. • Safety Training: Narrative and description of the Developer’s approach to safety training processes and hours of training to be provided at each Project Site. A minimum of four hours of safety training shall be provided to the Host Site Owner at each Project Site. • Emergency Responders Training: Narrative and description of Emergency Responders training processes and hours of training at each Project Site. The Developer shall provide

Section No.	Section Title	Sub No.	Sub Title	Requirements
				training to the local emergency responders at each Project Site. This training shall include electrical safety, shutdown procedures, and firefighting methods for dealing with emergencies that occur with EVs. A minimum of four hours of training shall be provided at each Project Site.
3.	Site Planning and Design	(a)	Lighting	Adequate lighting shall be considered during site planning. LED lighting may be implemented when placing the lighting. All Project Site lighting shall be consistent with existing and surrounding lighting features. New lighting in Project Site without any existing and surrounding lighting features is recommended to follow AASHTO Roadway Lighting Design Guide.
		(b)	Landscape and Curbside	As a condition to Services Commencement, the Developer shall replace any disturbed pavement, hardscape, landscape per associated Project Site Layout or replaced to its original conditions.
		(c)	Parking Spaces	Developer may elect to delineate parking spaces at the Project Site. Any stenciled or designated parking spaces shall comply with <u>Exhibit 2-2</u> requirements.
		(d)	Signage, Marking, Striping	Developer may elect to deploy signage at the Project Site. All signage deployed at the Project Site shall comply with FHWA Manual on Uniform Traffic Control Devices and <u>Exhibit 2-2</u> requirements clearly identifying the locations of the Charging Ports within the charging site.
		(e)	ADA Requirement	Project Site shall comply with ADA requirements and shall have at least one ADA-compliant parking space with access to an EVSE. The site shall provide ADA-accessible path to any facilities, amenities or other features. An EVSE that is accessible from an ADA-compliant parking space shall be positioned such that it can also be accessed from a non-ADA-compliant parking space that doesn't otherwise have access to an EVSE. The ADA parking space shall adhere to the

Section No.	Section Title	Sub No.	Sub Title	Requirements
				requirements of the US Access Board: https://www.access-board.gov/ta/tad/ev/#accessible-mobility-features .
		(f)	Project Site Access	Project Site shall be accessible from a public roadway with defined traffic control measures (signs, striping, or traffic signals). Project Site shall be physically accessible to the public 24 hours per day, seven days per week, year-round.
4.	Electrical Safety	(a)		<p>The Developer must ensure that electrical safety standards are met at all times according to Good Industry Practice including, but not limited to, the following:</p> <ul style="list-style-type: none"> • EVSE shall have a Charge Circuit Interrupting Device (CCID) or Ground Fault Circuit Interrupter (GFCI) to shut off flow of electric power to reduce risk of electric shock (see UL - Standard 2231). • EVSE shall have over-current protection rated for the application. All components, including electrical equipment, shall have to withstand current rating and other ratings appropriate for the application so as to not reduce the required safe power output capabilities of the chargers. • EVSE and any external accessories (if applicable) shall have outdoor-rated enclosure - NEMA 3R or greater. • Ensure conduits and other electrical apparatus follow all applicable state and local electrical and fire codes, protecting cable and other equipment from inadvertent damage by vehicles moving into place. Use cable management systems or other means to prevent cable insulation, wiring, and cooling systems from being damaged. • Subcontractors shall not modify components of existing or new equipment or structure in any way that will jeopardize UL or other safety ratings of the equipment or facility. • For placement of distribution cabinets and EVSE ensure

Section No.	Section Title	Sub No.	Sub Title	Requirements
				local codes are followed. Rather than wall-mounted (unit-strut) applications, consider commercial pedestals to house equipment including the meter, distribution panel, potential transformers, current transformers, etc.
5.	Fire Prevention and Safety	(a)		<p>The Developer must ensure that fire prevention and safety standards are met at all times according to industry best practices including, but not limited to, the following:</p> <ul style="list-style-type: none"> • At a minimum, EVSE must be installed per the latest National Electric Code (NFPA 70 or NEC) and National Fire Protection Association (NFPA 30A) standards, however all applicable state and local codes will also apply. • A fire department emergency power disconnect shall be provided within 50 feet of the EVSE installed at the Project Site, but no closer than 10 feet to any charger or cabinet. A Phenolic plaque with red background and 2-inch white lettering stating “FD Emergency Shutoff – Electric Vehicle Charging Station” shall be installed at each disconnect. • Existing or new construction and placement of hydrants, standpipe systems, and other means to extinguish a fire event shall adhere to all local building codes and NFPA standards. • A 24-hour call-in number must be provided by the Developer for customers, site hosts, and all other stakeholders to contact in case of issues. Matters involving the need for police, fire, and emergency medical services shall be directed to 911 operators.
6.	Utility Connection, Load Management, and Demand			<p>The Developer will be responsible for coordination with utility service providers and utility power connection and data communication network availability at the Project Site.</p> <p>The Developer shall coordinate with Utilities for applicable</p>

Section No.	Section Title	Sub No.	Sub Title	Requirements
	Response			<p>permitting requirements and any utility build-out required to provide power connection and data communication to the Project Site. Utility build-out may involve both Minor Utility Upgrade and Major Utility Upgrade, in each case the Developer shall coordinate with Utilities for applicable permitting. The Developer shall not be reimbursed for Major Utility Upgrade or any other Ineligible Costs. Utility build-out shall avoid all nonpermissible activities under the NEPA Approval that may trigger a NEPA re-evaluation. Refer to Section 4.4.5 (NEPA Approval) of the Agreement</p> <p>The Developer must coordinate with the local utility provider to confirm that expected power demand will remain within the capacity of the designed electrical system.</p> <p>The Developer shall ensure that the network communications, controls, and back-office support service shall have the ability to monitor energy usage (kWh) and energy demand (kW) of the EVSE at all times. Where applicable, network communications, controls, and back-office support service shall have the ability to respond to utility provided demand response signals via the Open Automated Demand Response 2.0b (latest or equivalent) protocol.</p>
7.	Security	(a)	Cybersecurity Plan	The Developer shall develop and adhere to the Cybersecurity Plan, which must satisfy the requirements set forth in the Cybersecurity Specifications.
		(b)	Cybersecurity Standards	The Developer shall ensure that all elements of the Project including charging, payment, data storage, data dissemination, and communication infrastructure meet the Cybersecurity Specifications.
		(c)		The Developer must ensure that physical security standards are

Section No.	Section Title	Sub No.	Sub Title	Requirements
			Physical Security	<p>met at all times according to Good Industry Practice including, but not limited to, the following:</p> <ul style="list-style-type: none"> • Project Site shall include security design features to remain tamper-resistant and vandalism resistant, such as tamper-resistant screws, anti-vandalism hardware, locked enclosures, and graffiti-resistant coating or paint. Vandal resistance is intended mostly to prevent, deter, and detect unauthorized physical access. Developer must submit IK impact rating in joules for touch screens and ensure they are rated for the application. • Unexpected or unauthorized accesses must be immediately communicated in writing to ADOT and all affected individuals. • Physical protection, such as bollards, shall be provided to protect the EVSE infrastructure from damage.
8.	Data Requirements	(a)	Data Submittal Requirements	In addition to the federal requirements outlined in in Section 4 (Data Submittal) of the NEVI Federal Standards and Requirements, the Developer shall adhere to the data submittal requirements outlined within <u>Exhibit 2-3 (Data Requirements), Section 2 (Data Submittal Requirements)</u> .
		(b)	Data Sharing Requirements	In addition to the federal requirements outlined in in <u>Section 6(c) (Third-Party Data Sharing)</u> of the NEVI Federal Standards and Requirements, the Developer shall adhere to the data sharing requirements outlined within <u>Exhibit 2-3 (Data Requirements), Section 3 (Data Sharing Requirements)</u> .
		(c)	Data Interface Control Document (ICD) Requirements	In addition to the federal requirements outlined in in <u>Section 4 (Data Submittal)</u> of the NEVI Federal Standards and Requirements, the Developer shall adhere to the data ICD requirements outlined within <u>Exhibit 2-3 (Data Requirements), Section 4 (Interface Control Document Requirements)</u> .

Section No.	Section Title	Sub No.	Sub Title	Requirements
9.	Minimum Quarterly Uptime	(a)	-	<p>Each Charging Port shall have an average annual uptime of greater than 97%, subject to the following requirements:</p> <ol style="list-style-type: none"> (1) A Charging Port is considered “up” when its hardware and software are both online and available for use, or in use, and the Charging Port successfully dispenses electricity in accordance with requirements for minimum power level (see Section 1(d) (Power Level) of the NEVI Federal Standards and Requirements). (2) Charging Port uptime must be calculated on a monthly basis for the previous Calendar Quarter. “Quarterly Uptime” equals the average port uptime for the months in the Calendar Quarter. (3) Charging Port uptime percentage must be calculated on a trailing 12-month average basis for each of the months included in the Quarterly Performance Report using the following equation: $\mu = ((X - (\text{Outage} - \text{Excluded})) / X) \times 100$ <p>where: μ = port uptime percentage; X = total minutes in the preceding 12 months Outage = total minutes of Outage in the preceding 12 months caused by the following instances of inoperability:</p> <ol style="list-style-type: none"> i. Charging Port is unable to accept all payment types; ii. Charging Port is not providing 100 percent of the power requested by the EV; and iii. Charging Port is not communicating with the EV connected to it.

Section No.	Section Title	Sub No.	Sub Title	Requirements
				<p>Excluded = total minutes of Outage in the preceding 12 months caused by an O&M Relief Event, including following reasons outside the charging Developer’s control, provided that the Developer can demonstrate that the Charging Port would otherwise be operational:</p> <ul style="list-style-type: none"> i. electric utility service interruptions, ii. failure to charge or meet the EV charging customer’s expectation for power delivery due to the fault of the vehicle, iii. scheduled maintenance, iv. vandalism, or v. natural disasters.
10.	Specifications, and Installation Guides	(a)	-	<p>The Developer must provide to ADOT complete manufacturers’ and/or suppliers’ specifications and installation guides for all EVSE. This information must also include any infrastructure required for the installation of a charger, including placement of bollards and curb stops.</p>
11.	Equipment Certification and Testing Requirements	(a)	-	<p>The Developer shall be responsible for confirming that standard factory testing has been completed and for conducting post-installation testing for each Charger to verify functionality and access to provide the data required under the NEVI Federal Rule, as further outlined in Sections 4 (Data Submittal) and 6 (Information on EV charging infrastructure locations, pricing, real time availability, and accessibility through mapping) of the NEVI Federal Standards and Requirements.</p> <p>EVSE and other equipment certification and testing results shall be provided to ADOT for review and approval in accordance with Section 5.3 (Services Commencement) of the Agreement. ADOT</p>

Section No.	Section Title	Sub No.	Sub Title	Requirements
				(or its designee) will perform independent testing and verification for conformance to the NEVI Federal Standards and Requirements and the Agreement.
12.	Customer Service	(a)	-	<p>The Developer shall establish and maintain a customer service phone line and online support (web-based or smartphone application-based) that is available 24 hours per day, seven days a week. The Developer shall use the customer service phone line to provide support and responses to all inquiries and comments from EVSE users who are using or attempting to use the EVSE.</p> <p>The Developer shall ensure that customer service meets the minimum NEVI Federal Standards and Requirements as outlined in Section 1 (Installation, operation, and maintenance by qualified technicians of Electric Vehicle charging infrastructure) of the NEVI Federal Standards and Requirements.</p>
13.	Additional Requirements	(a)	EVSE	<p>The Developer must ensure that all equipment installed at the Project Site as part of the D&C Work meets the following minimum requirements:</p> <ul style="list-style-type: none"> • Project Site and all EVSE shall be capable of operating in an ambient temperature range and relative humidity suited for the environment they will be installed to prevent corrosion, rust, and other issues related to extreme temperatures and condensation. • Project Site and all EVSE shall be able to withstand extreme weather conditions including sun exposure, minor flooding, heavy rains, high winds, snow, and ice, and is protected from malfunctions due to condensation. Cabinets and above ground structures shall be designed to withstand a 90 MPH wind load. • Any form of graphics including branding, logos, and/or art, included on or in the vicinity of the charging stations within

Section No.	Section Title	Sub No.	Sub Title	Requirements
				<p>the public right-of-way are subject to the rules and regulations as directed by ADOT. Vendors shall not use or post any ADOT branding, logos, or signs including ADOT branding or logos.</p> <ul style="list-style-type: none"> • Project Site and all EVSE screen displays shall be LCD, LED or equivalent or better, user friendly, easy to operate, daylight and night viewable, and UV-protected with human-machine interface capability and operable with gloves. • Project Site and all EVSE shall be accessible by ADOT, Arizona Department of Agriculture, or authorized agency representative, upon request for inspection, testing, etc. during the Term.
		(b)	Decommissioning Activities	<p>Developer must perform general restoration landscaping and hardscaping activities to replace any disturbed pavement, hardscape, landscape to its original conditions <u>(except to the extent waived in writing by the Host Site Owner)</u>. General restoration activities <u>shall</u> include:</p> <ul style="list-style-type: none"> • Removal of all EVSE charging infrastructure including: EV charging pedestals and ports, aerial or ground wires, physical security hardware and features, and all other related hardware <u>(provided, however, that removal of underground infrastructure may be waived in writing by the Host Site Owner)</u>. • Shallow grading, tilling, and planting to smooth surface and/or bring in soil prior to planting. • <u>For the avoidance of doubt, removal of EVSE charging infrastructure (except with respect to underground infrastructure as described above), is required notwithstanding any direction or waiver from Host Site Owner.</u>

Exhibit 2-1: Key Personnel Requirements

Table 1: Key Personnel Position

Position	Role	Minimum Qualifications	Commitment
Project Manager (PM)	Responsible to lead the Developer’s team during the D&C Period. This person serves as the single point of contact for all contract administration and correspondence with ADOT.	Experience in a management role for projects of similar size and complexity as the Project.	Full-Time On-Call upon NTP (Design and Materials) until end of the Term.
Design Manager	Responsible for ensuring compliance with design specifications, standards, and requirements for the Project during the D&C Period.	Experience in the same or similar role for projects of similar size and complexity as the Project. Must be Electric Vehicle Infrastructure Training Program (EVITP) certified.	Full-Time On-Call upon NTP (Design and Materials) to Services Commencement
Construction Manager/Electrician	Responsible for overseeing the day-to-day construction including EVSE installation, quality control, supervising construction activities and tasks, ensuring compliance with construction specifications, standards, and requirements for the Project, ensuring safety and environmental compliance during the D&C Period. Responsible for proactive utility coordination and responsive to public sensitivities.	Experience in the same or similar role for projects of similar size and complexity as the Project. Must be Electric Vehicle Infrastructure Training Program (EVITP) certified. ¹⁸	Full-Time On-Call upon NTP (Design and Materials) to Services Commencement
O&M Manager	Responsible to lead the Developer’s team during the O&M Period. Serves as the single point of contact for all issues related to O&M Work.	Experience in the same or similar role for projects of similar size and complexity as the Project.	Full-Time On-Call upon Services Commencement until end of the Term.

¹⁸ [NOTE TO PROPOSERS: Construction Manager/Electrician may be one or two people, at least one of whom must be EVITP certified.](#)

Exhibit 2-2: On-Premises Signing and Marking Requirements

1. Signing

1.1. Charging Space

Each Project Site shall have vertical signage (on same post). A Manual on Uniform Traffic Control Devices for Streets and Highways (MUTCD) D9-11b (Alternate) (symbol) or D9-11bP (text) shall be used to identify the space.



D9-11bP

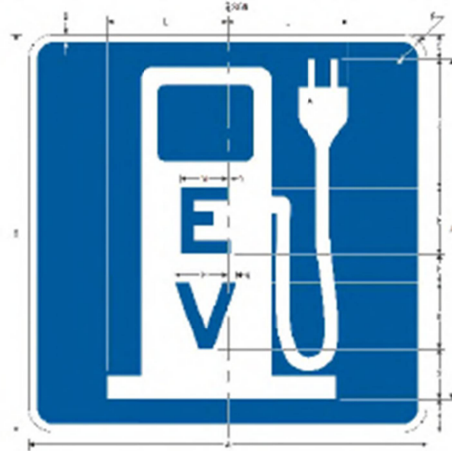

D9-11b

An additional plaque may be above the D9 sign to denote a particular space has fast charging capability.

A R7-11 sign may be used to indicate space is only for Electric Vehicle (EV) charging. A supplemental sign, R7-114, may be added to indicate specific charging time requirements.

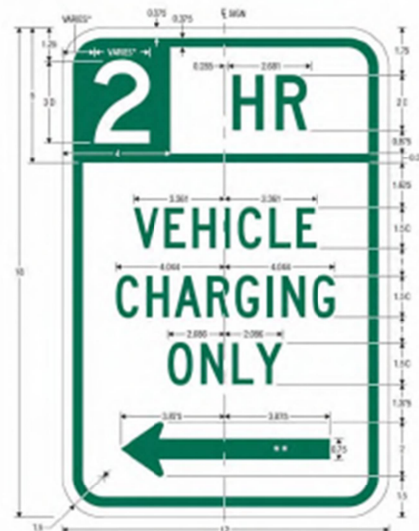

R7-11

R7-114

A R7-113aP and/or R7-113bP sign may be used to indicate vehicle must be plugged in to use the parking space and to vacate the space once charging is complete.



R7-113aP



R7-113bP

1.2. Wayfinding

D9-11b (Alternate) or D9-11bP with M series arrow may be added to direct drivers to the charging space(s) as necessary.



D9-11bp

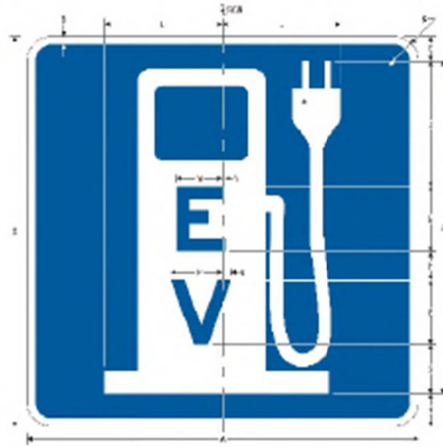

D9-11b

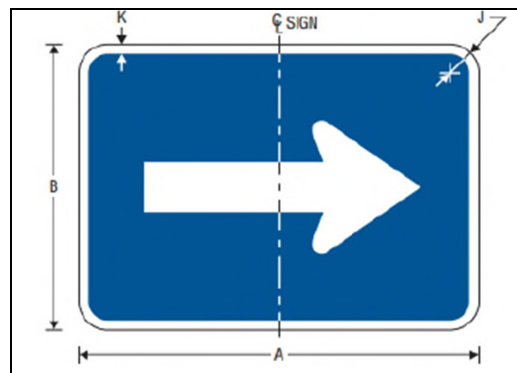

2. Pavement Marking

5" Solid Green (Pantone Number 354) pavement marking shall be used to delineate charging space. "EV CHARGING ONLY" and/or symbol should be centered in charging space.

Charging Space

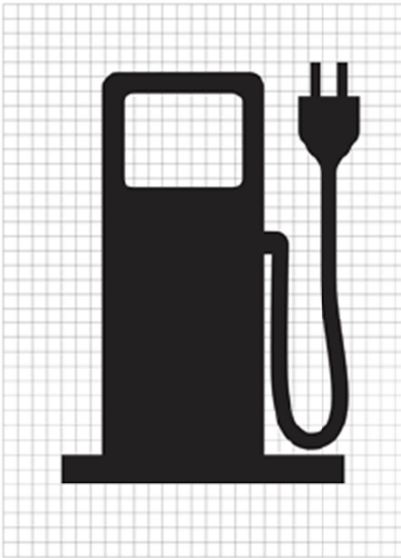

Exhibit 2-3: Data Requirements

1. Introduction

ADOT is responsible for ensuring EV charging infrastructure data is submitted to the Joint Office of Energy and Transportation (the “**Joint Office**”) under 23 CFR 680.112 and ensuring the Developer shares Electric Vehicle (EV) charging infrastructure data with other parties under 23 CFR 680.116.

The Joint Office is developing the Electric Vehicle Charging Analytics and Reporting Tool (“**EV-ChART**”), which will provide a web-based centralized hub for collecting EV charging infrastructure data.

This attachment details the requirements for the Developer to presubmit EV charging infrastructure data to EV-ChART for ADOT’s review, approval, and formal submittal and share data with other parties as prescribed below.

2. Data Submittal Requirements

The Joint Office has published an EV-ChART Data Format and Preparation Guidance document (for data required under 23 CFR 680.112), which defines the field name, definition, accepted values (i.e., format), and reporting frequency requirements for each EV charging infrastructure data attribute. The data attributes prescribed by the EV-ChART Data Format and Preparation Guidance document, including the reporting frequency, data format, and distribution requirements, are subject to change.

The Developer will gather the data necessary to presubmit to EV-ChART for ADOT review, approval and formal submittal.

The EV-ChART Data Format and Preparation Guidance document can be found at <https://driveelectric.gov/resources/>, which includes the reporting standards for data to be presubmitted.

2.1. General Data Submittal Requirements

The Developer shall ensure all required data attributes, prescribed by the EV-ChART Data Format and Preparation Guidance document, are collected, and submitted to EV-ChART based on the defined reporting frequency and data format in the EV-ChART Data Format and Preparation Guidance document and template.

The Developer shall ensure any data submitted to EV-ChART is aggregated and anonymized to protect confidential business and Personally Identifiable Information while also providing the data attributes required in Section 2.2, Section 2.3, and Section 2.4.

2.2. Quarterly Data Submittal Requirements

Developer shall ensure the following data attributes are collected and presubmitted to EV-ChART part of the Quarterly Data Submittal in accordance with Section 7.1.1(b) (Data Reporting), and in the manner prescribed by the EV-ChART Data Format and Preparation Guidance document:

- 1) Charger ID*
- 2) Connector ID*
- 3) Energy Charged
- 4) Network Provider ID*
- 5) Outage Duration
- 6) Outage ID
- 7) Payment Method
- 8) Payment Method Description*
- 9) Peak Power
- 10) Port ID
- 11) Session End
- 12) Session Error
- 13) Session Error Description*
- 14) Session ID
- 15) Session Start
- 16) Station ID
- 17) Total Excluded Outage
- 18) Total Outage
- 19) Uptime
- 20) Uptime Reporting End Date
- 21) Uptime Reporting Start Date

2.3. Annual Data Submittal Requirements

Developer shall ensure the following required data attributes are collected and presubmitted to EV-ChART as part of the Annual Data Submittal in accordance with Section 7.1.1(c) (Data Reporting), in a manner prescribed by the EV-ChART Data Format and Preparation Guidance document:

- 1) Charging as a Service*
- 2) Opportunity Program Description*
- 3) Opportunity Program Participation
- 4) Opportunity Program Reporting Year
- 5) Federal Maintenance and Repair Cost
- 6) Maintenance and Repair Cost Reporting End Date
- 7) Maintenance and Repair Cost Reporting Start Date
- 8) Station ID
- 9) Total Maintenance and Repair Cost

2.4. One-Time Data Submittal Requirements

Developer shall ensure the following data attributes are collected and presubmitted to EV-ChART as part of the One-time Data Submittal in accordance with Section 7.1.1(a) (Data Reporting), and in a manner prescribed by the EV-ChART Data Format and Preparation Guidance document:

- 1) Charging Equipment Acquisition Date*
- 2) Charging Equipment Acquisition Owned*
- 3) Charging Equipment Installation Cost – Construction Material*
- 4) Charging Equipment Installation Cost – Electric Material*
- 5) Charging Equipment Installation Cost – Labor*
- 6) Charging Equipment Installation Cost – Other*
- 7) Charging Equipment Installation Date*
- 8) DER Asset Type*
- 9) DER Upgrade*
- 10) Distributed Energy Acquisition Owned*
- 11) Distributed Energy Resource On-Site
- 12) Energy Storage Capacity
- 13) Federal Charging Equipment Acquisition Cost
- 14) Federal Charging Equipment Installation Cost
- 15) Federal Distributed Energy Acquisition Cost
- 16) Federal Distributed Energy Installation Cost
- 17) Federal Distribution Cost
- 18) Federal Real Property Acquisition Cost
- 19) Federal Service Cost
- 20) Federal System Cost
- 21) Power Output Capacity
- 22) Project ID*
- 23) Real Property Acquisition Date*
- 24) Real Property Acquisition Owned*
- 25) Station Address*
- 26) Station City*
- 27) Station Latitude*
- 28) Station Longitude*
- 29) Station State*
- 30) Station Upgrade*
- 31) Station Zip*
- 32) Station Zip Extended*
- 33) Station ID
- 34) Station Operator Address
- 35) Station Operator City
- 36) Station Operator Name
- 37) Station Operator State
- 38) Station Operator ZIP
- 39) Station Operator Zip Extended*

- 40) Total Charging Equipment Acquisition Cost
- 41) Total Charging Equipment Installation Cost
- 42) Total Distributed Energy Acquisition Cost
- 43) Total Distributed Energy Installation Cost
- 44) Total Distribution Cost
- 45) Total Real Property Acquisition Cost
- 46) Total Service Cost
- 47) Total System Cost

3. Data Sharing Requirements

The Developer shall develop an application programming interface (API) to share data in a machine-readable format (e.g., .JSON, .XML) with federal partners, third-party software developers, ADOT, and other interested parties.

3.1. General Data Sharing Requirements

The Developer shall utilize an industry standard API specification agreed upon by ADOT (e.g., OpenAPI).

The Developer shall ensure any data shared via an API is aggregated and anonymized to protect confidential business and Personally Identifiable Information while also providing the data attributes required in Section 3.2.

The Developer shall make the API accessible to federal partners, third-party software developers, ADOT, and any requesting party free of charge.

The Developer shall ensure data made available via the API is:

- 1) Formatted to align with the EV-ChART Data Format and Preparation Guidance document when applicable; and
- 2) Formatted based upon an agreed upon data format when not defined in the EV-ChART Data Format and Preparation Guidance document.

The Developer shall allow ADOT to consume data from the Developer's API and make it available to other parties.

3.2. Third-Party Data Sharing Requirements

Developer shall collect and make the following data attributes available, free of charge via an API:

Defined in EV-ChART Data Format and Preparation Guidance document:

- 1) Station ID
- 2) Station Address
- 3) Station City

- 4) Station State
- 5) Station ZIP
- 6) Station Latitude
- 7) Station Longitude
- 8) Station Operator Name

Not Defined in EV-ChART Data Format and Preparation Guidance document:

- 1) Charging Network Provider Name
- 2) Charging station status (operational, under construction, planned, or decommissioned)
- 3) Charging station access information:
 - a. Charging station access type (public or limited to commercial vehicles)
 - b. Charging station access days/times (hours of operation for the charging station)
- 4) Charging Port information:
 - a. Number of Charging Ports
 - b. Unique port identifier (defined in EV-ChART Data Format and Preparation Guidance document as Port ID)
 - c. Connector types available by port
 - d. Charging level by port (DCFC, AC Level 2, etc.)
 - e. Power delivery rating in kilowatts by port
 - f. Accessibility by vehicle with trailer (pull-through stall) by port (yes/no)
 - g. Real-time status by port in terms defined by Open Charge Point Interface 2.2.1
- 5) Pricing and payment information:
 - a. Pricing structure
 - b. Real-time price to charge at each Charging Port, in terms defined by Open Charge Point Interface 2.2.1

- c. Payment methods accepted at charging station

4. Interface Control Document Requirements

The Developer shall provide a comprehensive Interface Control Document (ICD).

4.1. General ICD Requirements

The ICD shall provide the technical details for:

- 1) Submitting data to EV-ChART; and
- 2) Sharing data with the federal partners, third-party software developers, ADOT, and any requesting party through the Developer's API.

The ICD shall provide all the API information necessary to help federal partners, third-party software developers, ADOT, and any requesting party use the API including:

- 1) The industry standard API specification;
- 2) Data field names, definitions, and accepted values (i.e., format) (similar to that defined in EV-ChART Data Format and Preparation Guidance);
- 3) Reporting frequency of data;
- 4) A description of the API functionality;
- 5) References (i.e., endpoints of the API); and
- 6) User guides and use-cases.

The Developer shall make the ICD easily available to federal partners, third-party software developers, ADOT, and any requesting party who wishes to use the API.

The Developer shall allow ADOT to share the Developer's ICD with other parties.

The ICD shall be formatted for 8.5" x 11" printing.

The ICD shall be delivered in Microsoft Word and PDF format.

Exhibit 2-4

EV Charging Infrastructure Cybersecurity Specifications



ADOT EV Charging Infrastructure Cybersecurity Specification

CHAPTER 1. TERMINOLOGY AND ABBREVIATIONS

ACRONYMS

Abbreviation	Meaning
ADOT	Arizona Department of Transportation
ARC-IT	Architecture Reference for Cooperative and Intelligent Transportation
CISA	Cybersecurity and Infrastructure Security Agency
CSO	Charging Station Operator
CSMS	Charging Station Management System
CVE	Common Vulnerabilities and Exposures
EV	Electric Vehicle
EVSE	Electric Vehicle Supply Equipment
ICS-CERT	Industrial Control Systems Cyber Emergency Response Team
ITS	Intelligent Transportation Systems
IVI	In-Vehicle Infotainment Center
NEVI	National Electric Vehicle Infrastructure
NERC-CIP	North American Electric Reliability Corporation Critical Infrastructure Protection
NIST	National Institute of Standards and Technology
OBE	On-Board Equipment
OCPP	Open Charge Point Protocol
PCI DSS	Payment Card Industry Data Security Standard

TERMS

Term	Definition
Charging Station	The physical system where Electric Vehicles can be charged.
Charging Station Operator	The mobility partner who operates the charging station infrastructure. For purposes of this specification this term will simultaneously refer to the Charging Station Vendor since the vendor is fulfilling this same role.
Connector/Plug	An independently operated and managed electrical outlet on a charging station which corresponds to a single physical connector.
Electric Vehicle Supply Equipment	An independently operated and managed part of the charging station that can deliver energy to one EV at a time.

REQUIREMENTS TERMINOLOGY

The key words "MUST," "MUST NOT," "REQUIRED," "SHALL," "SHALL NOT," "SHOULD," "SHOULD NOT," "RECOMMENDED," "MAY," and "OPTIONAL" in this document are to be interpreted as described in the Internet Engineering Task Force Requests for Comment 2110⁴¹ and 2119,⁴² which are defined in the below table.

Key Word	Definition
MUST	This word, or the terms "REQUIRED" or "SHALL," mean that the definition is an absolute requirement of the specification.
MUST NOT	This phrase, or the phrase "SHALL NOT," mean that the definition is an absolute prohibition of the specification.
SHOULD	This word, or the adjective "RECOMMENDED," mean that there may exist valid reasons in particular circumstances to ignore a particular item, but the full implications must be understood and carefully weighed before choosing a different course.
SHOULD NOT	This phrase, or the phrase "NOT RECOMMENDED" mean that there may exist valid reasons in particular circumstances when the particular behavior is acceptable or even useful, but when the full implications should be understood, and the case carefully weighed before implementing any behavior described in this label.
MAY	This word, or the adjective "OPTIONAL," mean that an item is truly optional. One vendor may choose to include the item because a particular marketplace requires it or because the vendor feels that it enhances the product while another vendor may omit the same item. An implementation which does not include a particular option MUST be prepared to interoperate with another implementation which does include the option, though perhaps with reduced functionality. In the same vein an implementation which does not include a particular option MUST be prepared to interoperate with another implementation which does not include the option (except, of course, for the feature the option provides.)

CHAPTER 2. INTRODUCTION

PURPOSE

The purpose of this specification is to establish a statewide cybersecurity standard for the deployment of Electric Vehicle (EV) charging infrastructure along the state's NEVI Formula Program funded EV charging installations by illustrating cybersecurity provisions derived from federal laws and regulations, and industry best standards to create cybersecurity requirements which the Charging Station Operator (CSO) MUST strictly and completely fulfill regarding the deploying and maintaining of EV charging infrastructure throughout the state of Arizona's EV charging installations.

Through strict adherence to the requirements in this document, the CSO can assure ADOT that the EV charging infrastructure met a baseline of substantial cybersecurity controls throughout ADOT's EV Infrastructure Deployment Plan.

SCOPE

- Requirements in this specification apply strictly to and are the responsibility of the CSO.
- Requirement items in this specification MUST be strictly and completely fulfilled by the CSO and submitted to ADOT for assessment.

CHAPTER 3. CYBERSECURITY RATIONALE

To establish the foundation of cybersecurity for the state of Arizona's EV charging installations, ADOT has constructed a set of requirements which correspond with both federal laws & regulations and industry best practice cybersecurity controls. These requirements are based primarily on cybersecurity provisions from the *NEVI Formula Program Guidance and the National Electric Vehicle Infrastructure Standards and Requirements (Title 23 CFR Part 680)*⁴³ and the *National ITS Architecture and Standards (ARC-IT)* conformity requirements from the *Intelligent Transportation System Architecture and Standards (Title 23 CFR Part 940)*.⁴⁴ The narrative for requirement creation and steps are described herein.

CONTROL MAPPING

A crosswalk mapping all relevant cybersecurity provisions present in the various requirement sources and NIST SP 800-53⁴⁵ was created. Primary and secondary requirement sources utilized in this mapping are described below.

PRIMARY

NEVI

In order to address the cybersecurity provisions in *Title 23 CFR Part 680*, each provision was mapped to applicable cybersecurity controls defined in NIST SP 800-53r5 *Security and Privacy Controls for Information Systems and Organizations*.⁴⁶

ARC-IT

Next, the cybersecurity requirements defined in ARC-IT's *Device Class 5 Areas*⁴⁷ (the security class applicable to ARC-IT's "Electric Charging Station" physical object) were mapped to applicable NIST SP 800-53 controls in much the same manner.

SECONDARY

Statewide Policy (8130): System Security Acquisition and Development

ADOT relied on its own *System Security Acquisition and Development Statewide Policy (P8130)*,⁴⁸ which contains relevant third-party information system acquisition and deployment controls for the Payment Card Industry Data Security Standard⁴⁹ (PCI DSS) and the Health Insurance Portability Act⁵⁰ in order to meet the customer and payment info cybersecurity considerations defined in *Title 23 CFR Part 680*. The PCI DSS and HIPAA controls⁵¹ contained within this statewide policy document were mapped to the applicable NIST SP 800-53 controls.

North American Electric Reliability Corporation Critical Infrastructure Protection (NERC CIP)

To address the cybersecurity consideration contained within *Title 23 CFR Part 680* defining the security of *Charging-Network-to-Grid Communication*, NERC CIP standards were utilized (*NERC CIP-011-2 "Information Protection" Requirements 1.1 & 1.2*)⁵² and mapped to NIST SP 800-53.

CONTROL BASELINE

An initial cybersecurity baseline was constructed in accordance with NIST SP 800-53Br5 *Control Baselines for Information Systems and Organizations*⁵³ tuned to the *Security Control Baseline* of “High”, which was further modified with supplemental controls which were a product of the mapping crosswalk.

CREATION OF REQUIREMENTS

Submission of NIST SP 800-53A Assessment

Title 23 CFR Part 940 pertains to additions of modifications to ITS systems which are funded partly or in whole by the Highway Trust Fund.⁵⁴ This requirement was created to fulfill the conformity provisions present in *Title 23 CFR Part 940* as it pertains to ITS conformity requirements with *The National ITS Architecture and Standards (ARC-IT)*, of which therein defines “Securing ITS” as a core architectural directive. Fulfillment of the current cybersecurity baseline (Appendix A) covers the physical components with the security class of *ARC-IT's Device Class 5 Areas*.⁵⁵

Fulfillment of Cybersecurity Compliance Controls Table

This requirement was created to meet cybersecurity provisions defined in *Title 23 CFR Part 680* by taking each particular cybersecurity provision and citing the cybersecurity baseline and component each provision should apply to. From there, the CSO MUST submit their plan to meet each requirement in the table.

Security Testing and Assessment - NIST SP 800-115

This section elaborates on the expectations with respect to security testing and assessment, guided by *NIST SP 800-115 Technical Guide to Information Security Testing and Assessment*.⁵⁶ The goal of this guidance is to ensure that vendors and owners regularly conduct security testing and assessments to demonstrate the effectiveness of security controls established in equipment, software, and networks utilized by EV charging infrastructure components. The CSO shall ensure that the activities outlined in NIST SP 800-115 are conducted on a regular interval, which includes policy reviews, vulnerability assessments, penetration testing, and others, as well as creating and maintaining a plan which shall define the logistical and technical details required to execute these activities.

CHAPTER 4. EV CHARGING INFRASTRUCTURE COMPONENTS

This section illustrates the multiple components which comprise electric vehicle charging infrastructure as defined in ARC-IT and OCPP diagrams and documentation. For the purpose of this specification, the CSO MUST address requirements for each relevant component listed when filling out requirements (see Chapter 5. Cybersecurity requirements for further details).

COMPONENT LIST

Below is a list of components owned by the CSO which facilitate the charging station's functionality.

Component	Description
Electric Vehicle Charging Station	Provides access to electric vehicle supply equipment that is used to charge hybrid and all-electric vehicles. For the purpose of this specification, this component will include the EVSE and connector(s). This component is provided, owned, and managed by the CSO.
CSMS	The system utilized by the CSO to manage charging stations. A majority of the CSMS core functions, including collection and management, overlap with that of the <i>Traffic Information Center</i> defined in ARC-IT. This system is owned and managed by the CSO.
PCI DSS Compliant Vehicle Payment Service	Supports vehicle payments for charging of EVs. Charging stations may utilize various methods of payment, to include an interface on the charging station itself which accepts debit/credit payment, or contactless methods in which the operator engages with the charging station remotely via either a mobile phone application or other OBE methods such as in-vehicle applications via the EV's IVI. Payment service mechanisms are provided, owned, and managed by the CSO.
PCI DSS Compliant Payment Administration Center	Provides general payment administration capabilities and supports the electronic transfer of funds from the customer to the CSO for charging services rendered. This system may be owned and managed by the CSO.

COMPONENT DIAGRAMS

Below are physical and interface diagrams of EV charging stations from ARC-IT and OCPP documentation. These are included as a resource for the CSO and others to describe the various components of EV charging infrastructure. [Note: “Electric Charging Station” as labeled by these ARC-IT diagrams is synonymous with “EV Charging Station” as utilized in this document.]

ARC-IT

ST05: Electric Charging Stations Management⁵⁷ – Physical Diagram

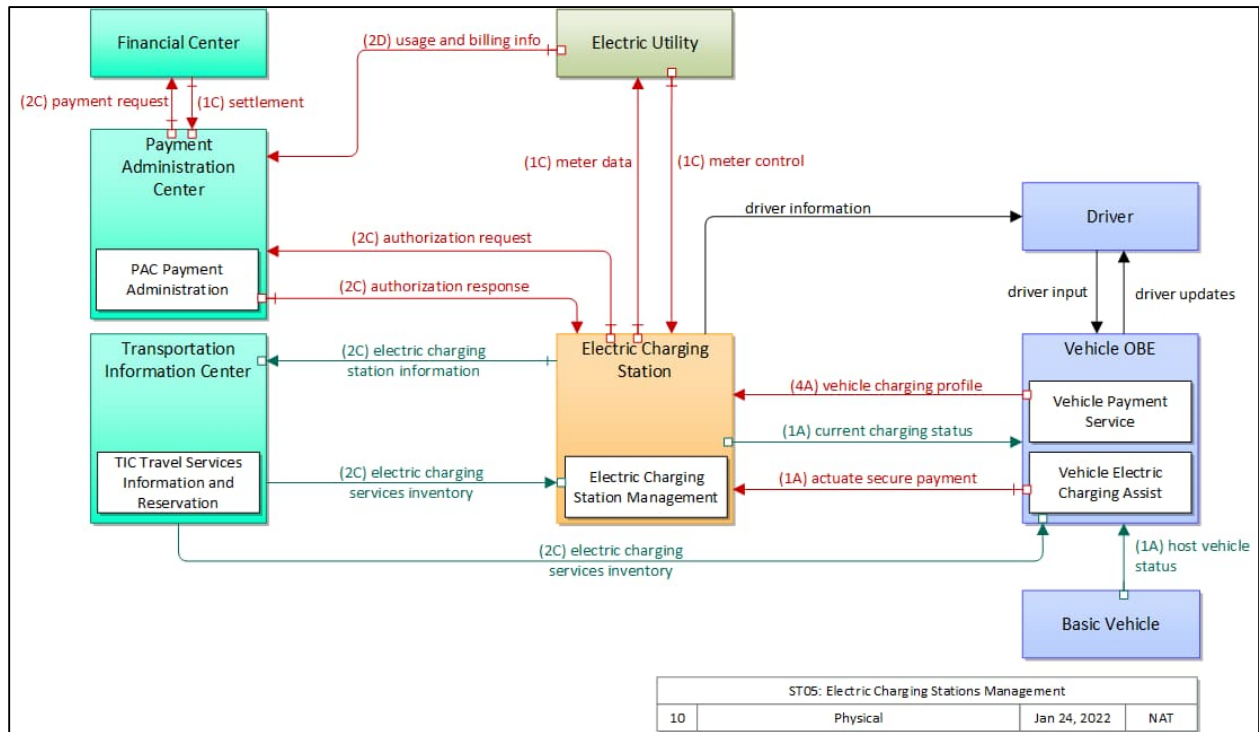

Figure E-4-1. ARC-IT Physical Diagram - ST05: Electric Charging Stations Management

Electric Charging Station – Interfaces Diagram

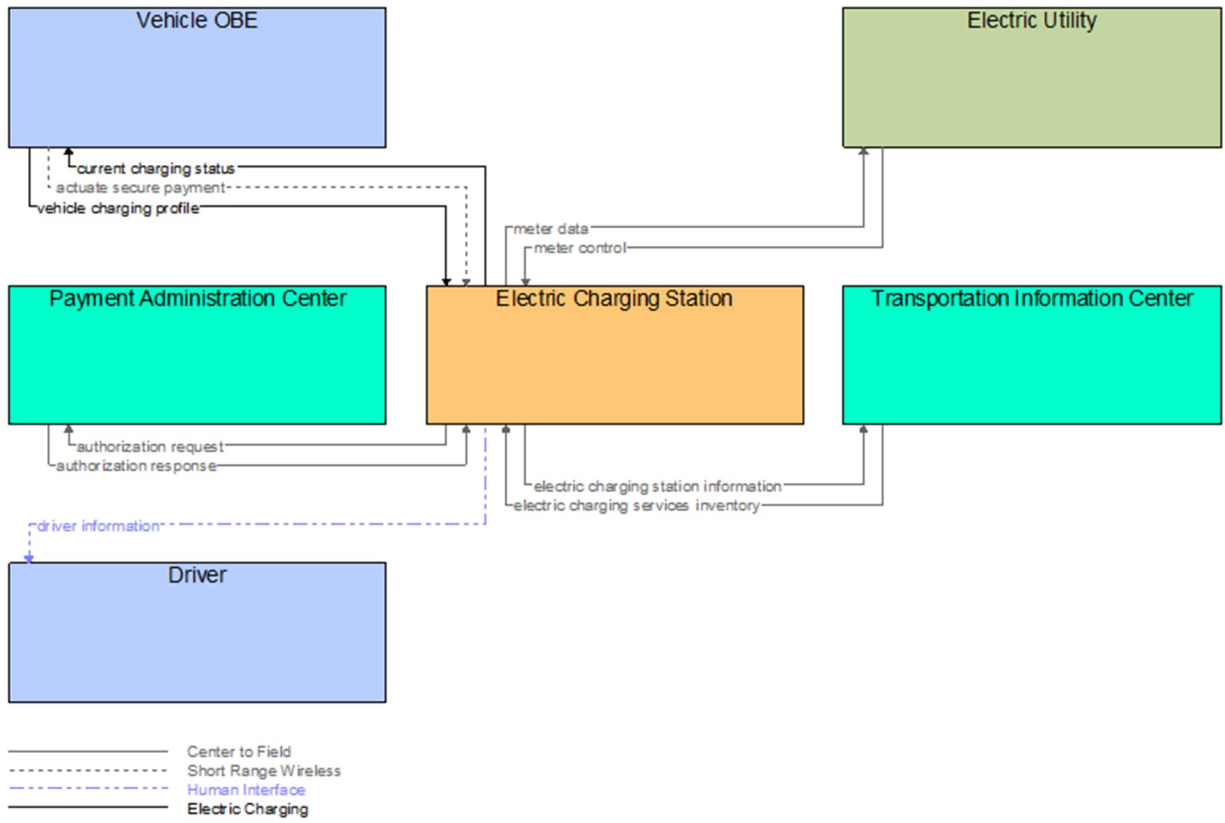

Figure E-4-2. ARC-IT Interfaces Diagram – Electric Charging Station

Open Charge Point Protocol

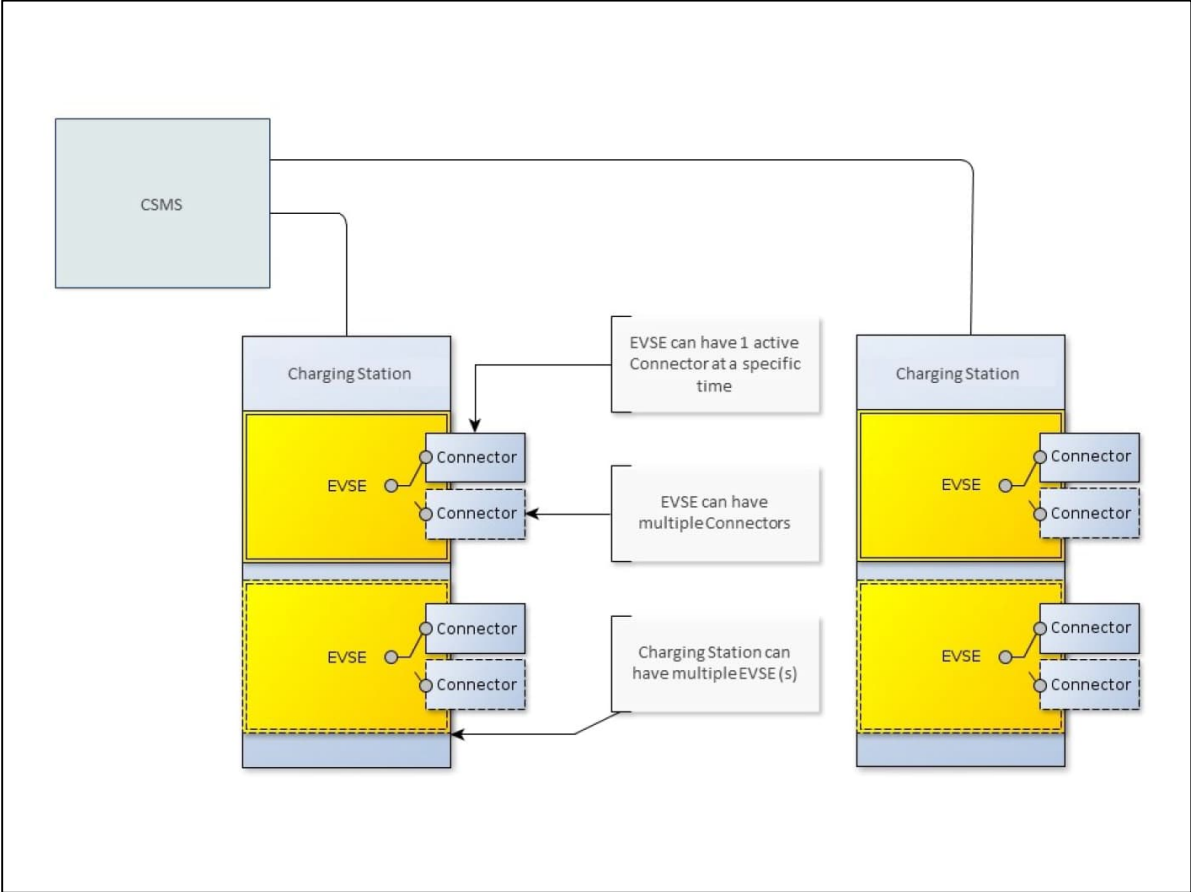

Figure E-4-3. 3-tier model as used in OCPP

CHAPTER 5. CYBERSECURITY REQUIREMENTS

This section contains mandatory cybersecurity requirements the CSO must fulfill. These requirements exist to fulfill the following cybersecurity provisions:

- Cybersecurity considerations present in the *NEVI Formula Program* and requirements defined the *NEVI Formula Program Guidance and the National Electric Vehicle Infrastructure Standards and Requirements (Title 23 CFR 680)*. View *Appendix B* for exact definitions.
- Device Class 5 Areas⁵⁸ (security Controls) defined in the *National ITS Architecture Reference/Architecture Reference for Cooperative and Intelligent Transportation (ARC-IT)* for *Electric Charging Station*⁵⁹ and *Vehicle Payment Service*.⁶⁰ View *Appendix B* for exact definitions.

•

The mandatory cybersecurity requirements are detailed in section *REQUIREMENT SUBMISSION GUIDELINES* below, and steps include:

7. Submission of NIST SP 800-53A Assessment⁶¹
8. Fulfillment of Cybersecurity Compliance Controls Table
9. Security Testing and Assessment – NISP SP 800-115⁶²

• Though these requirements may be addressed in any order, it is RECOMMENDED that the CSO address each requirement in numerical order. By completing step 1 *Submission of NIST SP 800-53A Assessment* first, this significantly expedites step 2 *Fulfillment of Cybersecurity Compliance Controls Table*.

•

REQUIREMENT SUBMISSION GUIDELINES

Submission of NIST SP 800-53A Assessment

The CSO is required to submit the attached *NIST SP 800-53A* assessment spreadsheet, fulfilling each control listed in *Table E-6A-1. Cybersecurity Control Baseline* in Appendix A. Fulfillment of each control must be met for each component as applicable. If a control is deemed as non-applicable for one or more components, then CSO must provide further detail in *Column I – “EXPLANATION & COMMENTS”* of the assessment document. For certain requirements with no present control, the CSO must provide a detailed explanation as to how exactly they are meeting the requirement for each component. While this baseline has been designed to incorporate PCI-DSS required controls outlined in ADOT P8130, the CSO shall be responsible for putting further controls in place as required by the latest version of the PCI DSS for payment systems.

While assessing each control, the CSO MUST annotate in *Column I – “EXPLANATION & COMMENTS”* how each control is applying to each component.

Cybersecurity Compliance Controls Table

Each requirement listed in the Cybersecurity Compliance Controls Table must be addressed and filled out in full by the CSO.

Column/Field Descriptions & Requirements

Cybersecurity Compliance Controls Table Columns	
Column	Description
#	Numeric identifier of each requirement.
Requirement	The stated cybersecurity requirement which must be met by the CSO.
Baseline Controls	The controls which fulfill the stated requirement.
Comp. Code	<p>Component code for each component a requirement applies to. The codes are as follows:</p> <ul style="list-style-type: none"> - CS: EV Charging Station - MS: CSMS - PS: Vehicle Payment Service - PA: Payment Administration Center <p>If one of more of the components listed above are deemed as non-applicable to the charging station deployment by the CSO, then the CSO must provide in detail which components meet non-applicable status and a detailed explanation as to why it's non-applicable. This explanation must be provided in the column titled "Compliance Description" on how they are to meet said requirement. The CSO may also add listed component codes to this cell which weren't previously listed by default and must provide a detailed explanation on that component's inclusion into the requirement. Requirements will apply to all newly added component(s).</p>
Compliance Status	<p>CSO must denote compliance status by inputting a bold and capitalized X in the sub-column:</p> <ul style="list-style-type: none"> - Yes if the requirement is fully and strictly met for all listed component codes for the relevant requirement. - No if requirements are not fully and strictly met for 1 or more of the listed component codes for the relevant requirement.
Compliance Description	<p>This is where the CSO must describe:</p> <ul style="list-style-type: none"> - Compliance status. - Plan to address compliance for the relevant requirement item.

- Any components which are deemed as *non-applicable* for the charging infrastructure deployment and a detailed explanation as to why.
- Any added components outside of the default listed components which are deemed as applicable to the charging infrastructure deployment, and a detailed explanation as to why.

Each cell contains default pre-filled text which may contain additional information or description needs which the CSO must address in their entry.

Cybersecurity Compliance Controls Table

#	Requirement	Initial Control Baseline	Comp. Code	Compliance Status		Compliance Description
				Yes	No	
1	Ensure contactless remote payment methods are secure.	NIST SP 800-53 Control Numbers: AC-4;AC-10;AC-25;CA-2;CA-7;CA-8;PE-3;PL-8;PM-4;RA-3;RA-5;SA-3;SA-4SA-5;SA-8;SA-10;SA-11;SA-15;SA-17;SC-7;SI-2;SI-3;SI-4;SI-5;SI-12;SI-13; SI-14;SI-16; SI-17;SR-2;SR-3;SR-4;SR-5;SR-6;SR-7;SR-8;SR-9;SR-10	CS; MS; PS; PA			A detailed plan shall be provided that addresses how contactless payment methods will be secured on the charging station. Include payment methods applicable to the charging station in explanation (i.e., mobile app, terminal payment, etc). This plan shall additionally incorporate and maintain compliance with all elements of the latest versions of PCI DSS and PCI SCC.
2	Physical security strategies to address EV charging station tampering and unauthorized access.	NIST SP 800-53 Control Numbers: PE-1;PE-2;PE-3;PE-4;PE-5;PE-6;PE-8;PE-9;PE-10;PE-11;PE-12;PE-13;PE-14;PE-15;PE-16;PE-17;PE-18	CS			A detailed plan shall be provided that addresses physical security strategies of the charging station.

3	Cybersecurity strategies to address user identity and access management, selection of appropriate encryption systems, intrusion and malware detection, event logging and reporting, management of software updates, and secure operation during communication outages.	NIST SP 800-53 Control Numbers: AC-1;AC-2;AC-3;AC-5;AC-6;AC-7;AC-8;AC-10;AC-11;AC-12;AC-14;AC-17;AC-18;AC-19;AC-20;AC-21;AC-22;AU-1;AU-2;AU-3;AU-4;AU-5;AU-6;AU-7;AU-8;AU-9;AU-10;AU-11;AU-12;IA-1;IA-2;IA-3;IA-4;IA-5;IA-6;IA-7;IA-8;IA-11;IA-12;MA-1;MA-2;MA-3;MA-4;MA-5;MA-6; SI-1;SI-2;SI-3;SI-4;SI-5;SI-6;SI-7;SI-8;SI-10;SI-11;SI-12;SI-16;SI-18	CS; MS; PS	A detailed plan shall be provided that addresses user identity and access management, selected encryption systems, intrusion and malware detection, event logging and reporting, management of software updates, and secure operation during communication outages.
4	Ensure secure collection, processing, and retention of only the personal information strictly necessary to provide charging service to the customer, to include information required to complete the charging transaction.	NIST SP 800-53 Control Numbers: AC-1;AC-2;AC-3;AC-5;AC-6;AC-7;AC-8;AC-10;AC-11;AC-12;AC-14;AC-17;AC-18;AC-19;AC-20;AC-21;AC-	CS; MS; PS; PA	A detailed plan shall be provided that addresses how the charging station will account for and enact secure collection, processing, and retention of personal information strictly necessary to provide charging service.
				To address "...secure operation during communication outages" describe the plan in detail on how you will persist service under this circumstance.

22;AT-1;AT-
2;AT-3;AT-
4;AU-1;AU-
2;AU-3;AU-
4;AU-5;AU-
6;AU-7;AU-
8;AU-9;AU-
10;AU-11;AU-
12;CA-1;CA-
2;CA-3;CA-
5;CA-6;CA-
7;CA-8;CA-
9;IR-1;IR-2;IR-
3;IR-4;IR-5;IR-
6;IR-7;IR-
8;MP-1;MP-
2;MP-3;MP-
4;MP-5;MP-
6;MP-7;PL-
1;PL-2;PL-
4;PL-8;PL-
10;PL-11;PM-
3;PM-5;PM-
18;PM-19;PM-
20;PM-21;PM-
22;PM-24;PM-
25;PM-26;PM-
27;PT-2;PT-
3;PT-4;PT-
5;PT-6;SA-
1;SA-2;SA-
3;SA-4;SA-
5;SA-8;SA-
9;SA-10;SA-
11;SA-15;SA-
16;SA-17;SA-
21;SA-22;SI-
1;SI-2;SI-3;SI-
4;SI-5;SI-6;SI-
7;SI-8;SI-10;SI-

		11;SI-12;SI-16;SI-18		
5	Enact <i>Charger-to-Charger-Network</i> communications using a secure communication method.	NIST SP 800-53 Control Numbers: SC-1;SC-2;SC-3;SC-4;SC-5;SC-7;SC-8;SC-10;SC-12;SC-13;SC-15;SC-17;SC-18;SC-20;SC-21;SC-22;SC-23;SC-24;SC-28;SC-39	CS; MS	A detailed plan shall be provided that addresses how the charging station will secure communications to its charging network.
6	Ensure charging stations have the ability to receive and implement secure remote software updates, conduct real-time protocol translations, encryption and decryption, authentication, and authorization in their communications with charging networks.	NIST SP 800-53 Control Numbers: AC-1;AC-2;AC-3;AC-5;AC-6;AC-7;AC-8;AC-10;AC-11;AC-12;AC-14;AC-17;AC-18;AC-19;AC-20;AC-21;AC-22;AU-1;AU-2;AU-3;AU-4;AU-5;AU-6;AU-7;AU-8;AU-9;AU-10;AU-11;AU-12;IA-2;IA-3;IA-4;IA-5;IA-6;IA-7;IA-8;IA-11;IA-12;MA-1;MA-2;MA-3;MA-4;MA-5;MA-6;SC-	CS; MS	A detailed plan shall be provided that addresses how the charging station will secure remote software update receipt and implementation, conducts real-time protocol translations, handles encryption and decryption, enacts authentication and authorization in communications within their charging networks.

		1;SC-2;SC-3;SC-4;SC-5;SC-7;SC-8;SC-10;SC-12;SC-13;SC-15;SC-17;SC-18;SC-20;SC-21;SC-22;SC-23;SC-24;SC-28;SC-39;SI-1;SI-2;SI-3;SI-4;SI-5;SI-6;SI-7;SI-8;SI-10;SI-11;SI-12;SI-16;SI-18		
7	Ensure charging stations and charging networks securely measure, communicate, store, and report energy and power dispensed, real-time charging-port status, real-time price to the customer, and historical charging-port uptime.	NIST SP 800-53 Control Numbers: AC-1;AC-2;AC-3;AC-5;AC-6;AC-7;AC-8;AC-10;AC-11;AC-12;AC-14;AC-17;AC-18;AC-19;AC-20;AC-21;AC-22;SC-1;SC-2;SC-3;SC-4;SC-5;SC-7;SC-8;SC-10;SC-12;SC-13;SC-15;SC-17;SC-18;SC-20;SC-21;SC-22;SC-23;SC-24;SC-28;SC-39	CS; MS	A detailed plan shall be provided that addresses how the charging station securely measures, stores, communicates, and reports required information within their charging networks.
8	Ensure charging stations utilize appropriate cybersecurity use cases	OCP v2.0.1 Part 2 – Section A2	CS	List and provide detail here regarding which applicable use cases and

	and requirements in their communications with any charging network provider.	<i>"Use cases & Requirements"</i>		requirements are fulfilled and how. Additionally, list and provide detail regarding which use cases and requirements are deemed non-applicable to your charging station system.
9	Ensure charging stations are designed to securely switch charging network providers without any changes to hardware.	N/A	CS; MS	A detailed plan shall be provided that addresses the design strategy for securely switching charging network providers without any changes to hardware.
10	Ensure the charging network must be capable of communicating with other charging networks to enable an EV operator to utilize a single credential to charge at charging stations that are a part of multiple charging networks.	N/A	CS; MS; PS	A detailed plan shall be provided that addresses how the charging network will enable utilization of a single credential for EV operators to charge at charging stations that are a member of multiple charging networks.
11	Ensure charging networks are capable of secure communication with electric utilities, other energy providers, or local energy management systems.	NIST SP 800-53 Control Numbers: SI-1; SI-2; SI-3; SI-4; SI-5; SI-6; SI-7; SI-8; SI-10; SI-11; SI-12; SI-16; SI-18; SR-1; SR-2; SR-3; SR-5; SR-6; SR-8; SR-9; SR-10; SR-11; SR-12	CS; MS	A detailed plan shall be provided that addresses how the charging network will secure its communication with electric utilities, energy providers, and local energy management systems.

Security Testing and Assessment - NIST SP 800-115

Active assessment and testing of security controls and policies from both procedural and technical standpoints are critical to verify proper security control implementation and procedure compliance, as well as to demonstrate their practical effectiveness against modern cyber-attack methodologies. NIST SP 800-115 shall be utilized by system integrators, vendors and owners (CSO) of EV charging infrastructure as the guiding standard for security testing and assessment of their equipment and networks. For vendors, efforts shall include code reviews, periodic vulnerability analysis and security testing (white box and black box) of their equipment. For the CSO and system integrators, similar assessment efforts shall be conducted at the system level, with a primary focus on the network, interfaces, and site-specific configuration. Vulnerability scanning and penetration testing shall be conducted at both the equipment level (by the vendor) and at the system/network level (internal and external) by a professionally certified tester (e.g., OSCP, PNPT, eCPPT, or similarly qualified with demonstrated hands-on experience) using modern techniques, frameworks, and tools.

The CSO shall both develop cybersecurity assessment plans in accordance with section 6 of NIST SP 800-115. Assessment planning shall adhere to the following steps, which are quoted from section 6.7 of this standard:

- Developing a security assessment policy. Organizations should develop an information security assessment policy to provide direction and guidance for their security assessments. This policy should identify security assessment requirements and hold accountable those individuals responsible for ensuring that assessments comply with the requirements. The approved policy should be disseminated to the appropriate staff, as well as third parties who are to conduct assessments for the organization. The policy should be reviewed at least annually and whenever there are new assessment-related requirements.
- Prioritizing and scheduling assessments. Organizations should decide which systems should undergo assessments and how often these assessments should be done. This prioritization is based on system categorization, expected benefits, scheduling requirements, applicable regulations where assessment is a requirement, and resource availability. Technical considerations can also help determine assessment frequency, such as waiting until known weaknesses are corrected or a planned upgrade to the system is performed before conducting testing.
- Selecting and customizing technical testing and examination techniques. There are many factors for organizations to consider when determining which techniques should be used for a particular assessment. Factors include the assessment objectives, the classes of techniques that can obtain information to support those objectives, and the appropriate techniques within each class. Some techniques also require the organization to determine the assessors' viewpoint (e.g., internal versus external) so that corresponding techniques can be selected.
- Determining the logistics of the assessment. This includes identifying all required resources, including the assessment team; selecting environments and locations from which to perform the assessment; and acquiring and configuring all necessary technical tools. - Developing the assessment plan. The assessment plan documents the activities planned for an assessment and

other related information. A plan should be developed for every assessment to provide the rules and boundaries to which assessors must adhere. The plan should identify the systems and networks to be assessed, the type and level of testing permitted, logistical details of the assessment, data handling requirements, and guidance for incident handling. -

- Addressing any legal considerations. Organizations should evaluate potential legal concerns before commencing an assessment, particularly if the assessment involves intrusive tests (e.g., penetration testing) or if the assessment is to be performed by an external entity. Legal departments may review the assessment plan, address privacy concerns, and perform other functions in support of assessment planning.

The CSO SHALL, in concert with the requirement defined in section 3544 of the *Federal Information Security Modernization Act of 2014*,⁶³ conduct “periodic testing and evaluation of the effectiveness of information security policies, procedures, and practices, to be performed with a frequency depending on risk, but no less than annually.” This is echoed in the recommendation provided by NIST SP 800-115, which also recommends conducting such reviews “whenever there are new assessment-related requirements.” NIST SP 800-53 provides further recommendations regarding the frequency of conducting security assessments. Vulnerability scanning and penetration testing shall be part of the activities conducted at least annually.

Assessments for payment systems must additionally comply with all PCI-DSS requirements. A PCI Security Standards Council (SCC) certified Quality Security Assessor (QSA) shall be utilized to determine the appropriate assessment frequency of EV charging payment systems, to verify that the latest PCI DSS requirements are being properly met, and to review/recommend changes to plans and controls as required for the payment system to maintain PCI DSS compliance. Payment software must additionally comply with PCI SSC Software Standards.

CSO SHALL also actively monitor and react to threat intelligence (including new CVEs and ICS-CERT advisories related to elements of their systems) which may necessitate re-assessment of their equipment and/or networks and may require patching or re-configuration to mitigate risk from emerging threats. Vendors shall immediately inform owners of any such information that may adversely impact their systems and provide guidance for temporary and long-term mitigation of associated risks.

CHAPTER 6. APPENDICES

APPENDIX A – CYBERSECURITY BASELINE

Table E-6A-1 contains a listing of identifiers for cybersecurity control families and their enhancements for environments with a *High* security control baseline in accordance with NIST SP 800-53B r5, which has been further modified to include additional controls to meet requirements of *Title 23 CFR Part 680*, *Title 23 CFR Part 940*, and the *Statewide Policy (8130): System Security Acquisition and Development*.

Table E-6A-1. Cybersecurity Control Baseline

CYBERSECURITY CONTROL BASELINE		
Control Number	Control Name	Initial Control Baselines
Access Control		
AC-1	Policy and Procedures	AC-1
AC-2	Account Management	AC-2 (1) (2) (3) (4) (5) (11) (12) (13)
AC-3	Access Enforcement	AC-3
AC-4	Information Flow Enforcement	AC-4 (4)
AC-5	Separation of Duties	AC-5
AC-6	Least Privilege	AC-6 (1) (2) (3) (5) (7) (9) (10)
AC-7	Unsuccessful Logon Attempts	AC-7
AC-8	System Use Notification	AC-8
AC-10	Concurrent Session Control	AC-10
AC-11	Device Lock	AC-11 (1)
AC-12	Session Termination	AC-12
AC-14	Permitted Actions Without Identification or Authentication	AC-14
AC-17	Remote Access	AC-17 (1) (2) (3) (4)
AC-18	Wireless Access	AC-18 (1) (3) (4) (5)
AC-19	Access Control for Mobile Devices	AC-19 (5)

CYBERSECURITY CONTROL BASELINE

Control Number	Control Name	Initial Control Baselines
----------------	--------------	---------------------------

AC-20	Use of External Systems	AC-20 (1) (2)
AC-21	Information Sharing	AC-21
AC-22	Publicly Accessible Content	AC-22

Awareness and Training

AT-1	Policy and Procedures	AT-1
AT-2	Literacy Training and Awareness	AT-2 (2) (3)
AT-3	Role-based Training	AT-3
AT-4	Training Records	AT-4

Audit and Accountability

AU-1	Policy and Procedures	AU-1
AU-2	Event Logging	AU-2
AU-3	Content of Audit Records	AU-3 (1)
AU-4	Audit Log Storage Capacity	AU-4
AU-5	Response to Audit Logging Process Failures	AU-5 (1) (2)
AU-6	Audit Record Review, Analysis, and Reporting	AU-6 (1) (3) (5) (6)
AU-7	Audit Record Reduction and Report Generation	AU-7 (1)
AU-8	Time Stamps	AU-8
AU-9	Protection of Audit Information	AU-9 (2) (3) (4)
AU-10	Non-repudiation	AU-10
AU-11	Audit Record Retention	AU-11
AU-12	Audit Record Generation	AU-12 (1) (3)

Assessment, Authorization, and Monitoring

CYBERSECURITY CONTROL BASELINE

Control Number	Control Name	Initial Control Baselines
----------------	--------------	---------------------------

CA-1	Policy and Procedures	CA-1
CA-2	Control Assessments	CA-2
CA-3	Information Exchange	CA-3 (6)
CA-5	Plan of Action and Milestones	CA-5
CA-6	Authorization	CA-6
CA-7	Continuous Monitoring	CA-7 (1) (4)
CA-8	Penetration Testing	CA-8 (1)
CA-9	Internal System Connections	CA-9

Configuration Management

CM-1	Policy and Procedures	CM-1
CM-2	Baseline Configuration	CM-2 (2) (3) (7)
CM-3	Configuration Change Control	CM-3 (1) (2) (4) (6)
CM-4	Impact Analyses	CM-4 (1) (2)
CM-5	Access Restrictions for Change	CM-5 (1)
CM-6	Configuration Settings	CM-6 (1) (2)
CM-7	Least Functionality	CM-7 (1) (2) (5)
CM-8	System Component Inventory	CM-8 (1) (2) (3) (4)
CM-9	Configuration Management Plan	CM-9
CM-10	Software Usage Restrictions	CM-10
CM-11	User-installed Software	CM-11
CM-12	Information Location	CM-12 (1)

Contingency Planning

CP-1	Policy and Procedures	CP-1
CP-2	Contingency Plan	CP-2 (1) (2) (3) (5) (8)

CYBERSECURITY CONTROL BASELINE

Control Number	Control Name	Initial Control Baselines
----------------	--------------	---------------------------

CP-3	Contingency Training	CP-3 (1)
CP-4	Contingency Plan Testing	CP-4 (1) (2)
CP-6	Alternate Storage Site	CP-6 (1) (2) (3)
CP-7	Alternate Processing Site	CP-7 (1) (2) (3) (4)
CP-8	Telecommunications Services	CP-8 (1) (2) (3) (4)
CP-9	System Backup	CP-9 (1) (2) (3) (5) (8)
CP-10	System Recovery and Reconstitution	CP-10 (2) (4)

Identification and Authentication

IA-1	Policy and Procedures	IA-1
IA-2	Identification and Authentication (organizational Users)	IA-2 (1) (2) (5) (8) (12)
IA-3	Device Identification and Authentication	IA-3
IA-4	Identifier Management	IA-4 (4)
IA-5	Authenticator Management	IA-5 (1) (2) (6)
IA-6	Authentication Feedback	IA-6
IA-7	Cryptographic Module Authentication	IA-7
IA-8	Identification and Authentication (non-organizational Users)	IA-8 (1) (2) (4)
IA-11	Re-authentication	IA-11
IA-12	Identity Proofing	IA-12 (3) (4) (5)

Incident Response

IR-1	Policy and Procedures	IR-1
IR-2	Incident Response Training	IR-2 (1) (2)
IR-3	Incident Response Testing	IR-3 (2)
IR-4	Incident Handling	IR-4 (1) (4) (11)

CYBERSECURITY CONTROL BASELINE

Control Number	Control Name	Initial Control Baselines
----------------	--------------	---------------------------

IR-5	Incident Monitoring	IR-5 (1)
------	---------------------	----------

IR-6	Incident Reporting	IR-6 (1) (3)
------	--------------------	--------------

IR-7	Incident Response Assistance	IR-7 (1)
------	------------------------------	----------

IR-8	Incident Response Plan	IR-8
------	------------------------	------

Maintenance

MA-1	Policy and Procedures	MA-1
------	-----------------------	------

MA-2	Controlled Maintenance	MA-2 (2)
------	------------------------	----------

MA-3	Maintenance Tools	MA-3 (1) (2) (3)
------	-------------------	------------------

MA-4	Nonlocal Maintenance	MA-4 (3)
------	----------------------	----------

MA-5	Maintenance Personnel	MA-5 (1)
------	-----------------------	----------

MA-6	Timely Maintenance	MA-6
------	--------------------	------

Media Protection

MP-1	Policy and Procedures	MP-1
------	-----------------------	------

MP-2	Media Access	MP-2
------	--------------	------

MP-3	Media Marking	MP-3
------	---------------	------

MP-4	Media Storage	MP-4
------	---------------	------

MP-5	Media Transport	MP-5
------	-----------------	------

MP-6	Media Sanitization	MP-6 (1) (2) (3) (7) (8)
------	--------------------	--------------------------

MP-7	Media Use	MP-7
------	-----------	------

Physical and Environmental Protection

PE-1	Policy and Procedures	PE-1
------	-----------------------	------

PE-2	Physical Access Authorizations	PE-2
------	--------------------------------	------

PE-3	Physical Access Control	PE-3 (1)
------	-------------------------	----------

PE-4	Access Control for Transmission	PE-4
------	---------------------------------	------

CYBERSECURITY CONTROL BASELINE

Control Number	Control Name	Initial Control Baselines
----------------	--------------	---------------------------

PE-5	Access Control for Output Devices	PE-5
PE-6	Monitoring Physical Access	PE-6 (1) (4)
PE-8	Visitor Access Records	PE-8 (1)
PE-9	Power Equipment and Cabling	PE-9
PE-10	Emergency Shutoff	PE-10
PE-11	Emergency Power	PE-11 (1)
PE-12	Emergency Lighting	PE-12
PE-13	Fire Protection	PE-13 (1) (2)
PE-14	Environmental Controls	PE-14
PE-15	Water Damage Protection	PE-15 (1)
PE-16	Delivery and Removal	PE-16
PE-17	Alternate Work Site	PE-17
PE-18	Location of System Components	PE-18

Planning

PL-1	Policy and Procedures	PL-1
PL-2	System Security and Privacy Plans	PL-2
PL-4	Rules of Behavior	PL-4
PL-8	Security and Privacy Architectures	PL-8
PL-10	Baseline Selection	PL-10
PL-11	Baseline Tailoring	PL-11

Program Management

PM-3	Information Security and Privacy Resources	PM-3
PM-5	System Inventory	PM-5 (1)

CYBERSECURITY CONTROL BASELINE

Control Number	Control Name	Initial Control Baselines
----------------	--------------	---------------------------

PM-18	Privacy Program Plan	PM-18
PM-19	Privacy Program Leadership Role	PM-19
PM-20	Dissemination of Privacy Program Information	PM-20
PM-21	Accounting of Disclosures	PM-21
PM-22	Personally Identifiable Information Quality Management	PM-22
PM-24	Data Integrity Board	PM-24
PM-25	Minimization of Personally Identifiable Information Used in Testing, Training, and Research	PM-25
PM-26	Complaint Management	PM-26
PM-27	Privacy Reporting	PM-27

Personnel Security

PS-1	Policy and Procedures	PS-1
PS-2	Position Risk Designation	PS-2
PS-3	Personnel Screening	PS-3
PS-4	Personnel Termination	PS-4 (2)
PS-5	Personnel Transfer	PS-5
PS-6	Access Agreements	PS-6
PS-7	External Personnel Security	PS-7
PS-8	Personnel Sanctions	PS-8
PS-9	Position Descriptions	PS-9

PII Processing and Transparency

PT-2	Authority to Process Personally Identifiable Information	PT-2
------	--	------

CYBERSECURITY CONTROL BASELINE

Control Number	Control Name	Initial Control Baselines
----------------	--------------	---------------------------

PT-3	Personally Identifiable Information Processing Purposes	PT-3
PT-4	Consent	PT-4
PT-5	Privacy Notice	PT-5 (1) (2)
PT-6	System of Records Notice	PT-6

Risk Assessment

RA-1	Policy and Procedures	RA-1
RA-2	Security Categorization	RA-2
RA-3	Risk Assessment	RA-3
RA-5	Vulnerability Monitoring and Scanning	RA-5 (2) (4) (5) (11)
RA-7	Risk Response	RA-7
RA-8	Privacy Impact Assessments	RA-8
RA-9	Criticality Analysis	RA-9

System and Services Acquisition

SA-1	Policy and Procedures	SA-1
SA-2	Allocation of Resources	SA-2
SA-3	System Development Life Cycle	SA-3
SA-4	Acquisition Process	SA-4
SA-5	System Documentation	SA-5
SA-8	Security and Privacy Engineering Principles	SA-8
SA-9	External System Services	SA-9
SA-10	Developer Configuration Management	SA-10
SA-11	Developer Testing and Evaluation	SA-11

CYBERSECURITY CONTROL BASELINE

Control Number	Control Name	Initial Control Baselines
----------------	--------------	---------------------------

SA-15	Development Process, Standards, and Tools	SA-15 (3)
SA-16	Developer-provided Training	SA-16
SA-17	Developer Security and Privacy Architecture and Design	SA-17
SA-21	Developer Screening	SA-21
SA-22	Unsupported System Components	SA-22

System and Communications Protection

SC-1	Policy and Procedures	SC-1
SC-2	Separation of System and User Functionality	SC-2
SC-3	Security Function Isolation	SC-3
SC-4	Information in Shared System Resources	SC-4
SC-5	Denial-of-service Protection	SC-5
SC-7	Boundary Protection	SC-7 (3) (4) (5) (7) (18) (21)
SC-8	Transmission Confidentiality and Integrity	SC-8 (1)
SC-10	Network Disconnect	SC-10
SC-12	Cryptographic Key Establishment and Management	SC-12 (1)
SC-13	Cryptographic Protection	SC-13
SC-15	Collaborative Computing Devices and Applications	SC-15
SC-17	Public Key Infrastructure Certificates	SC-17
SC-18	Mobile Code	SC-18
SC-20	Secure Name/address Resolution Service (authoritative Source)	SC-20

CYBERSECURITY CONTROL BASELINE

Control Number	Control Name	Initial Control Baselines
SC-21	Secure Name/address Resolution Service (recursive or Caching Resolver)	SC-21
SC-22	Architecture and Provisioning for Name/address Resolution Service	SC-22
SC-23	Session Authenticity	SC-23
SC-24	Fail in Known State	SC-24
SC-28	Protection of Information at Rest	SC-28 (1)
SC-39	Process Isolation	SC-39
System and Information Integrity		
SI-1	Policy and Procedures	SI-1
SI-2	Flaw Remediation	SI-2 (2)
SI-3	Malicious Code Protection	SI-3
SI-4	System Monitoring	SI-4 (2) (4) (5) (10) (12) (14) (20) (22)
SI-5	Security Alerts, Advisories, and Directives	SI-5 (1)
SI-6	Security and Privacy Function Verification	SI-6
SI-7	Software, Firmware, and Information Integrity	SI-7 (1) (2) (5) (7) (15)
SI-8	Spam Protection	SI-8 (2)
SI-10	Information Input Validation	SI-10
SI-11	Error Handling	SI-11
SI-12	Information Management and Retention	SI-12
SI-16	Memory Protection	SI-16
SI-18	Personally Identifiable Information Quality Operations	SI-18

CYBERSECURITY CONTROL BASELINE

Control Number	Control Name	Initial Control Baselines
----------------	--------------	---------------------------

Supply Chain Risk Management

SR-1	Policy and Procedures	SR-1
SR-2	Supply Chain Risk Management Plan	SR-2 (1)
SR-3	Supply Chain Controls and Processes	SR-3
SR-5	Acquisition Strategies, Tools, and Methods	SR-5
SR-6	Supplier Assessments and Reviews	SR-6
SR-8	Notification Agreements	SR-8
SR-9	Tamper Resistance and Detection	SR-9 (1)
SR-10	Inspection of Systems or Components	SR-10
SR-11	Component Authenticity	SR-11 (1) (2)
SR-12	Component Disposal	SR-12

APPENDIX B. DEFINITIVE TEXT

The excerpts below are extracted from normative references in this document and MUST NOT be accepted by the CSO as applicable cybersecurity requirements for the CSO, but instead the text is meant specifically as a reference.

The National Electric Vehicle Infrastructure (NEVI) Formula Program Guidance

Section III. STATE EV INFRASTRUCTURE DEPLOYMENT PLAN – B. Plan Format – Cybersecurity

This section of the Plan should discuss how the State will address cybersecurity. The Plan should identify considerations when software updates are made to ensure the station or vehicle is not compromised by malicious code, or that a vehicle infects other stations during future charges.

National Electric Vehicle Infrastructure (NEVI) Formula Program – NEVI Formula Program Guidance and the National Electric Vehicle Infrastructure Standards and Requirements - 23 C.F.R. § 680

§ 680.106 - Installation, operation, and maintenance by qualified technicians of electric vehicle charging infrastructure.

(f) Payment methods.

(1) Charging stations must provide for secure payment methods, accessible to persons with disabilities, which at a minimum shall include a contactless payment method that accepts major debit and credit cards, and Plug and Charge payment capabilities using the ISO 15118 standard (incorporated by reference, see § 680.120);

(h) Security. States must implement physical and cybersecurity strategies consistent with their respective State EV Infrastructure Deployment Plans to mitigate charging infrastructure, grid, and consumer vulnerability associated with the operation of charging stations.

(1) Physical security strategies may address lighting, siting, driver and vehicle safety, fire prevention, tampering, charger locks, and illegal surveillance of payment devices.

(2) Cybersecurity strategies may address user identity and access management, selection of appropriate encryption systems, intrusion and malware detection, event logging and reporting, management of software updates, and secure operation during communication outages.

(k) Customer service. States must ensure that EV charging customers have mechanisms to report outages, malfunctions, and other issues with charging infrastructure. States must comply with the American with Disabilities Act of 1990 requirements and multilingual access when creating reporting mechanisms.

(l) Customer data privacy. Charging Station Operators must collect, process, and retain only that personal information strictly necessary to provide the charging service to a consumer, including information to complete the charging transaction and to provide the location of charging stations to the consumer. Charging Stations Operators must also take reasonable measures to safeguard consumer data.

§ 680.114 - Charging network connectivity of electric vehicle charging infrastructure.

(a) Charger-to-Charger-Network communication.

(1) Chargers must communicate with a charging network via a secure communication method.

(2) Chargers must have the ability to receive and implement secure, remote software updates and conduct real-time protocol translation, encryption and decryption, authentication, and authorization in their communication with charging networks.

(3) Chargers and charging networks must securely measure, communicate, store, and report energy and power dispensed, real-time charging-port status, real-time price to the customer, and historical charging-port uptime.

(4) Chargers must be capable of using Open Charge Point Protocol (OCPP) (incorporated by reference, see § 680.120) to communicate with any Charging Network Provider.

(5) Chargers must be designed to securely switch Charging Network Providers without any changes to hardware.

(b) Charging-Network-to-Charging-Network communication. *A Charging Network must be capable of communicating with other Charging Networks to enable an EV driver to use a single credential to charge at Charging Stations that are a part of multiple Charging Networks.*

(c) Charging-Network-to-grid communication. *Charging Networks must be capable of secure communication with electric utilities, other energy providers, or local energy management systems.*

Architecture Reference for Cooperative and Intelligent Transportation (ARC-IT)

Device Class 5 Areas

Device Class 5:

- *Confidentiality: HIGH*
- *Integrity: HIGH*
- *Availability: HIGH*

Devices of this class must meet controls from NIST 800-53 and ISO/IEC 15408 in the following areas:

- *Access Control*
- *Audit and Accountability*
- *Configuration Management*
- *Contingency Planning*
- *Identification and Authentication*
- *Incident Response*
- *Media Protection*
- *Personal Privacy*
- *Risk Assessment*
- *System and Services Acquisition*
- *System and Communications Protection*
- *System and Information Integrity*

In addition, organizations that develop, operate or maintain devices of this class must meet controls from NIST 800-53 and ISO/IEC 15408 the areas above and the following additional areas:

- *Awareness and Training*
- *[Security] Assessment and Authorization*
- *Maintenance*
- *Physical and Environmental Protection*
- *Planning*
- *Personnel Security*

EXHIBIT 3

DEVELOPER'S PROPOSAL COMMITMENTS⁴⁸¹⁹

PART A: Developer Commitments

[To be populated based on Developer's Proposal.]

PART B: Project Schedule⁴⁹²⁰

No.	Milestone	Completion Date
1	Effective Date	[XX/XX/20XX]
2	Assumed NTP (Design and Materials)	[XX/XX/20XX]
3	Design and Permitting Completion	[XX/XX/20XX]
4	Power Utility Service Connection	[XX/XX/20XX]
5	Communication/Data Utility Service Connection	[XX/XX/20XX]
6	Project Site Preparation	[XX/XX/20XX]
7	EVSE and Associated Hardware Delivery	[XX/XX/20XX]
8	EVSE Installation	[XX/XX/20XX]
9	Services Commencement Deadline	[XX/XX/20XX]
10	Services Commencement Long Stop Date	[XX/XX/20XX]

PART C: Project Schedule of Values²⁰²¹

Row	Capital Cost Category	Total Eligible Capital Costs (\$)	Total Ineligible Capital Costs (\$)	Total Capital Costs (\$)
1	General conditions (includes insurance & bonds, administration, mobilization, overhead, and project management)			
2	Design and permitting			
3	Minor Utility Upgrade			
4	Onsite renewable energy & battery storage			
5	Site preparation			
6	Construction (excluding row 5 costs)			
7	EVSE hardware			
8	EVSE software			
9	Amenities and enhancements			
10	Project Site acquisition			
11	Major Utility Upgrade			

⁴⁸¹⁹ **NOTE TO PROPOSERS:** If applicable, multiple, individual project schedules and Schedules of Values for each applicable Project Site will be included.

⁴⁹²⁰ **NOTE TO PROPOSERS:** This will be ITP Form 2 Part C from the Developer.

²⁰²¹ **NOTE TO PROPOSERS:** This will be ITP Form 6-2 from the Developer.

12	Total (sum of above rows 1-11)			
13	Requested Federal Capital Cost Match			
14	Developer Share of Eligible Capital Costs			

PART D: Annual O&M Amount ²⁴²²

	O&M Period Year 1	O&M Period Year 2	O&M Period Year 3	O&M Period Year 4	O&M Period Year 5
Annual O&M Amount					

²⁴²² **NOTE TO PROPOSERS:** This chart will be populated by the amounts set forth in Line 4 of ITP Form 6-3 from the Developer.

Exhibit 4

PERFORMANCE DEDUCTIONS

Noncompliance Event		Threshold	Performance Deduction Amount
1.	Failure to comply with the reporting obligations under <u>Section 5.2 (D&C Period Reporting)</u> and <u>Section 9.6 (Quarterly Performance Reporting during the O&M Period)</u> .	N/A	\$250 per day for the D&C Period and O&M Period (as applicable)
2.	Failure to adhere to the NEVI Federal Uptime Requirement in the applicable O&M Year	Where the EVSE uptime for a Charging Port in an O&M Year is unavailable for an aggregate of: (a) zero to 11 days (b) between 12 to 73 days (c) between 74 and 183 days (d) 184 or more	Then, for each Charging Port, the Performance Deduction Amount is: (a) \$0; (b) \$250 per day per charging port; (c) \$500 per day per charging port; (d) \$1,000 per day per charging port.

Example of Performance Deductions calculation: If a charging port has a total annual uptime of 165 days (outage of 200 days with no excluded outages) in an O&M Year, the Performance Deductions would be assessed in the following order for the number of days where the charging port was not available:

Range	Downtime	Total Performance Deduction Amount Attributable to Range
Range 1	11 days of downtime	\$0
Range 2	62 days of downtime	\$15,500

Range	Downtime	Total Performance Deduction Amount Attributable to Range
Range 3	110 days of downtime	\$55,000
Range 4	17 days of downtime	\$17,000
Total Performance Deductions for charging port		\$87,500

Exhibit 5

PERFORMANCE REPORTS

PART A: D&C Period Progress Report

Instructions:

The Developer shall include the following components as part of each D&C Period Progress Report delivered in accordance with Section 5.2 (D&C Period Reporting):

1. Project Schedule Tracker in a tabular format such as MS Word or MS Excel using the Project Schedule, and identifying progress made against the Project Schedule using actual completion dates [for each applicable Project Site].
2. Project Schedule Narrative describing any risks, issues, or problems encountered or anticipated since the Effective Date and in the upcoming reporting periods, inclusive of any unusual labor, shift, equipment or material conditions, or restrictions encountered. The Developer shall include proposed and recommended solutions to each item identified.
3. Project Schedule of Values Tracker in MS Excel (.xlsx or equivalent) and PDF using the Project Schedule of Values [for each applicable Project Site], and identifying actual incurred costs. The Developer shall retain all records, bills of sale, and invoices related to all materials and labor for not less than five years from the Services Commencement Date and provide these records to ADOT upon request.

1. Project Schedule Tracker: ²²²³

No.	Milestone	Actual Completion Date	Comments
1	Effective Date	[XX/XX/20XX]	N/A
2	Assumed NTP (Design and Materials)	[XX/XX/20XX]	
3	Design and Permitting Completion	[XX/XX/20XX]	
4	Power Utility Service Connection	[XX/XX/20XX]	
5	Communication/Data Utility Service Connection	[XX/XX/20XX]	
6	Project Site Preparation	[XX/XX/20XX]	
7	EVSE and Associated Hardware Delivery	[XX/XX/20XX]	
8	EVSE Installation	[XX/XX/20XX]	
9	Services Commencement Deadlines	[XX/XX/20XX]	
10	Services Commencement Long Stop Date	[XX/XX/20XX]	N/A

2. Project Schedule Narrative:

- a. Description of (a) any risks, issues, or problems encountered since the Effective Date, and (b) recommendations to resolve such risks, issues, or problems:

- b. Description of (a) any risks, issues, or problems anticipated in the upcoming reporting periods, and (b) recommendations to resolve such risks, issues, or problems:

²²²³ **NOTE TO PROPOSERS:** Schedules to be included for each Project Site governed by the Project Agreement.

3. Project Schedule of Values Tracker:

Row	Capital Cost Category	Total Eligible Capital Costs (\$)	Total Ineligible Capital Costs (\$)	Total Capital Costs (\$)
1	General conditions (includes insurance & bonds, administration, mobilization, overhead, and project management)			
2	Design and permitting			
3	Minor Utility Upgrade			
4	Onsite renewable energy & battery storage			
5	Site preparation			
6	Construction (excluding row 5 costs)			
7	EVSE hardware			
8	EVSE software			
9	Amenities and enhancements			
10	Project Site acquisition			
11	Major Utility Upgrade			
12	Total (sum of above rows 1-11)			
13	Requested Federal Capital Cost Match			
14	Proposer Share of Eligible Capital Costs			

Submitted this _____ **[Date]** by:
 [_____] **[Developer]**
 By: _____
 Name: _____
 Title: _____

Arizona Department of Transportation
 By: _____
 Name: _____
 Title: _____

Approved this _____ **[Date]** by:

PART B: Quarterly Performance Reports

The Developer shall include the following components as part of each Quarterly Performance Report [for each applicable Project Site] in accordance with PA Section 9.6 (Quarterly Performance Reporting during the O&M Period).

Section 1: Session information

For each charging session that occurred in the prior Calendar Quarter, each Quarterly Performance Report shall include:

1. The unique session identifier.
2. The Charging Station identifier with which the following data can be associated. This must be the same Charging Station name or identifier used to identify the Charging Station in data made available to third parties in § 680.116(c)(1) of the Federal Requirements.
3. The Charging Port identifier. This must be the same Charging Port identifier used to identify the Charging Port in data made available to third parties in § 680.116(c)(8)(ii) of the Federal Requirements.
4. The charging session start time and date.
5. The charging session end time and date.
6. Any error codes associated with an unsuccessful charging session by port.
7. Energy (kWh) dispensed to EVs per charging session by port.
8. Peak session power (kW) by port.
9. Payment method associated with each charging session (plug-and-charge, app-base, card reader, toll-free phone).
10. Any outage that ends a session.

Note that only the above information should be included, and no personal identifying information should be included in the above elements.

Section 2: Annual maintenance and repair costs

For the Calendar Quarter ending on December 31, the Quarterly Performance Report shall include the total maintenance and repair costs incurred for each Charging Station.

Section 3: Minimum Quarterly Uptime Requirement

Each Quarterly Performance Report shall include the Developer's calculation of the Minimum Quarterly Uptime Requirement, calculated in accordance with Section 9(a) (Minimum Quarterly Uptime) of the ADOT Standards and Requirements.

Section 4: Customer Service

Each Quarterly Performance Report shall include the number and nature customer service requests received in connection with Part B of Exhibit 2 (ADOT Standards and Requirements), Section 12(a) (Customer Service).

Exhibit 6

INSURANCE

- (a) **Workers Compensation and Employer's Liability Insurance** with statutory workers compensation coverage and employer's liability limits of not less than \$1,000,000 each accident and \$1,000,000 bodily injury by disease applicable to employee and in the aggregate. If applicable, coverage shall be extended to include claims under the United States Longshoremen's and Harbor Workers Act, the Federal Employers Liability Act, and the Jones Act.
- (b) **Commercial General Liability Insurance** Commercial general liability insurance (CGL) with limits not less than \$1,000,000 each occurrence and \$2,000,000 general and completed operations aggregate (aggregate limit to apply on a per project or per location basis). Coverage shall include premises and operations, ~~independent contractors,~~ personal injury, products and completed operations, broad form property damage, and contractual liability. There shall be no endorsement or modification of the CGL coverage limiting the scope of coverage for liability arising from explosion, collapse, and underground property damage or for work within 50 feet of a railroad and there shall be a standard separation of insureds/cross-liability clause. ADOT, the State and the Indemnified Parties shall be named as additional insureds on a primary and noncontributory basis and include a waiver of subrogation.
- (c) **Automobile Liability Insurance** with a limit of not less than \$1,000,000 combined single limit. Such insurance shall cover liability, including bodily injury or death and property damage, arising out of any auto (including owned, hired, and non-owned autos) and ADOT, the State and the Indemnified Parties shall be added as additional insureds on a primary, non-contributory basis and include a waiver of subrogation. If no owned/leased vehicles, this coverage can be provided as part of the CGL policy noted above (i.e., include hired and non-owned auto coverage). Such policy must be endorsed as required to include Motor Carrier Act Endorsement-Hazardous Materials Clean-up (MCS-90) for those contractors who will at any time transport Hazardous Materials.
- (d) **Commercial Umbrella/Excess Liability Insurance** in excess of the above-noted limits for CGL, automobile liability and employer's liability with a limit of no less than \$3,000,000 per occurrence and in the aggregate. ADOT, the State and the Indemnified Parties shall be added as additional insureds on a primary, noncontributory basis. Excess/umbrella liability policy will follow form to the underlying primary general liability on a primary and noncontributory basis.
- (e) **Pollution Legal Liability Insurance** with a limit not less than \$1,000,000 encompassing all locations that are part of the Project. Such coverage may be written on either an occurrence or claim-made basis, however, if written on a claims-made basis, coverage shall continue to be carried for a period of three years following the end of the period. Coverage shall, at a minimum, be

extended to cover any transportation and non-owned off-site disposal and shall include all claims related to bodily injury, property damage (including diminution of value), and clean-up and remediation costs. ADOT, the State and the Indemnified Parties shall be added as additional insureds on the policy on a primary and noncontributory basis.

- (f) **Property Insurance** covering all risks of physical loss or damage to the project assets including, but not limited to, fire, lightning, explosion, collapse, wind, flood, named storm, resulting damage from faulty workmanship or design error, and earth movement/earthquake. Such coverage shall only be required once construction and installation is complete at any given location. The policy limit shall be written on a replacement cost basis and shall include extensions of coverage typical for a project of the nature of the Project. Coverage shall include, on a commercially-reasonable sublimited basis, demolition and debris removal, soft costs and increased costs for building code compliance. Business income interruption/loss of revenue to include extra expense, must also be included with a minimum limit of one year's loss of revenue. ADOT shall be added as an insured, as its interests may appear.
- (g) **Network Security/Privacy Liability Insurance** with a minimum limit of \$1,000,000 providing coverage for third-party network security or privacy liability claims as well as first-party insurance coverages for losses related to notification, credit monitoring, breach management and regulatory/legal compliance, technology errors and omissions, as well as business income interruption, extra expense, and ransomware/extortion. Such coverage shall only be required once any charging station is operational and information is being gathered and shared. ADOT and the Indemnified Parties shall be additional insureds with regard to Third-Party Claims arising from network security or privacy liability.
- (h) **Subcontractors.** Developer's certificate(s) shall include all Subcontractors as insureds under its policies, or Developer shall be responsible for ensuring and/or verifying that all Subcontractors have valid and collectable insurance as evidenced by the certificates of insurance and endorsements for each Subcontractor. All coverages for Subcontractors shall be subject to the minimum insurance requirements identified above. ADOT reserves the right to require, at any time throughout the life of this contract, proof from the Developer that its Subcontractors have the required coverage.

Exhibit 7

FORM OF D&C PERFORMANCE BOND AND D&C PAYMENT BOND

PART A: Form of D&C Performance Bond

Bond No. _____

DESIGN AND CONSTRUCTION (“D&C”) PERFORMANCE BOND

WHEREAS, the Arizona Department of Transportation (“**Obligee**”), has entered into that certain Project Agreement dated _____ (as may be amended and supplemented, the “**Agreement**”) with _____, a _____ (“**Principal**”) on the terms and conditions set forth therein; and

WHEREAS, the Principal is required to furnish a bond (this “**Bond**”) guaranteeing the faithful performance of its obligations under the Agreement.

NOW, THEREFORE, the Principal and _____, a _____ (“**Surety**”), holder of a certificate of authority to transact surety business in the State of Arizona, are held and firmly bound unto Obligee in the amount of [_____] Dollars (\$[____]) (the “**Bonded Sum**”) under the Agreement, for payment of which sum the Principal and Surety jointly and severally hereby bind themselves and their respective successors and assigns.

THE CONDITION OF THIS BOND IS SUCH THAT, if the Principal shall promptly and faithfully perform as required by the Agreement, including in respect of any payment obligations following a default by the Principal, and shall fully indemnify and save harmless the Obligee from all cost, expense, damage, injury or loss that the Obligee may suffer by reason of failure so to do, and shall fully reimburse and repay the Obligee all cost and expense that the Obligee may incur in making good any such default, then the obligation shall be null and void, otherwise this Bond shall remain in full force and effect.

PROVIDED, however, it shall be a condition precedent to any right of recovery hereunder that, in the event of any default on the part of the Principal, a written statement of the particular facts showing date and nature of such default shall be given by the Obligee to the Surety, and in any event, no later than 15 days hereafter, and shall be forwarded by registered mail to the Surety at its Branch Office.

AND PROVIDED FURTHER, that no action, suit or proceeding, except as hereinafter set forth shall be had or maintained against the Surety on this instrument unless the same be brought or instituted and process served upon the Surety within 12 months after termination of this Bond.

AND PROVIDED FURTHER, that the following terms and conditions shall apply with respect to this Bond:

1. The Agreement is incorporated by reference herein. Capitalized terms not separately defined herein have the meanings assigned such terms in the Agreement.

2. The Surety agrees that no change, extension of time, alterations, additions, omissions or other modifications of the terms of the Agreement, or in the work to be performed with respect to the Project, or in the specifications or plans, or any change or modification of any terms of payment or extension of time for any payment pertaining or relating to the Agreement, or any rescission or attempted rescission of the Agreement, or this Bond, or any conditions precedent or subsequent in this Bond attempting to limit the right of recovery of the Obligee, or any fraud practiced by any other person other than the Obligee seeking to recover from this Bond, shall in any way affect the obligations of the Surety on this Bond, and the Surety hereby waives notice of such changes, extensions of time, alterations, additions, omissions or other modifications. The Surety agrees that payments made under the D&C Payment Bond do not reduce the Surety's legal obligations under this Bond.

3. Correspondence or claims relating to this Bond should be sent to the Surety at the following address:

IN WITNESS WHEREOF, the said Principal and Surety have signed and sealed this instrument this ___ day of _____, 2023.

Principal: By: _____

Its: _____ (Seal)

Surety: By: _____

Its: _____ (Seal)

PART B: Form of D&C Payment Bond

Bond No. _____

DESIGN AND CONSTRUCTION (“D&C”) PAYMENT BOND

WHEREAS, the Arizona Department of Transportation (“Obligee”), has entered into that certain Project Agreement dated _____ (as may be amended and supplemented, the “Agreement”) with _____, a _____ (“Principal”) on the terms and conditions set forth therein; and WHEREAS, the Principal is required to furnish a bond (this “Bond”) guaranteeing payment of claims by Subcontractors and suppliers.

NOW, THEREFORE, the Principal and _____, a _____ corporation (“Surety”), holder of a certificate of authority to transact surety business in the State of Arizona, are held and firmly bound unto Obligee in the amount of \$_____ under the Agreement (the “Bonded Sum”), for payment of which sum the Principal and Surety firmly bind themselves and their respective successors and assigns.

THE CONDITION OF THIS BOND IS SUCH THAT, if Principal shall fail to pay any valid claims by Subcontractors and suppliers with respect to the Work, then the Surety shall pay for the same in an amount not to exceed the Bonded Sum.

PROVIDED, however, that the following terms and conditions shall apply with respect to this Bond:

1. The Agreement is incorporated by reference herein. Capitalized terms not separately defined herein have the meanings assigned such terms in the Agreement.

2. The Surety agrees that no change, extension of time, alterations, additions, omissions or other modifications of the terms of the Agreement, or in the Work to be performed with respect to the Project, or in the specifications or plans, or any change or modification of any terms of payment or extension of time for any payment pertaining or relating to the Agreement, or any rescission or attempted rescission of the Agreement, or this Bond, or any conditions precedent or subsequent in this Bond attempting to limit the right of recovery of the Obligee, or any fraud practiced by any other person other than the Obligee seeking to recover from this Bond, shall in any way affect the obligations of the Surety on this Bond, and the Surety hereby waives notice of such changes, extensions of time, alterations, additions, omissions or other modifications. The Surety agrees that payments made under the Performance Bond do not reduce the Surety’s legal obligations under this Bond.

3. Correspondence or claims relating to this Bond should be sent to the Surety at the following address:

4. This Bond shall inure to the benefit of Subcontractors and suppliers with respect to the Work so as to give a right of action to such persons and their assigns in any suit brought upon this Bond.

IN WITNESS WHEREOF, the said Principal and Surety have signed and sealed this instrument this day of _____, 2023.

Principal: By: _____

Its: _____ (Seal)

Surety: By: _____

Its: _____ (Seal)

Exhibit 8

**FORM OF ADOT LICENSE
LICENSE AGREEMENT**

This Agreement (“**Agreement**”) is made as of the ____ day of _____ (the “**Effective Date**”), by and between _____ (hereinafter “**Licensor**”), whose principal place of business is _____ and the **ARIZONA DEPARTMENT OF TRANSPORTATION**, a public agency of the State of Arizona (hereinafter “**ADOT**”), whose principal office is located at 206 S. 17th Avenue, Phoenix, Arizona 85007.

WITNESSETH:

WHEREAS, the Infrastructure Investment and Jobs Act (“**IJA**”), as set forth under Pub. L. No. 117-58, §§ 70901-52, dedicated funding to U.S. states for the strategic placement of electric vehicle charging stations and associated infrastructure and the establishment of an interconnected network to facilitate data collection, access, and reliability (the “**Program**”);

WHEREAS, under the Program, ADOT has awarded Licensor a contract as part of the ADOT’s implementation of the Arizona National Electric Vehicle Infrastructure (“**NEVI**”) Deployment Program;

WHEREAS, the Licensor will be required to install, construct, operate and maintain electric vehicle charging infrastructure (“**EV Charging Infrastructure**”) along the Alternative Fuel Corridors for the traveling public and ADOT will reimburse a certain percentage of Licensor’s cost and pursuant to an agreement between ADOT and the Licensor dated on or about the date of this Agreement (“**Project Agreement**”);

WHEREAS, Licensor owns and/or has obtained an interest in real property located in the City of _____, _____ County, Arizona, and more particularly described by Appendix A attached hereto (the “**Property**”) and incorporated herein by reference;

[**WHEREAS**, Licensor will install, construct, operate and maintain EV Charging Infrastructure at the Property pursuant to an agreement between the Licensor and the Property owner dated on or about the date of this Agreement (“**Host Site Agreement**”);]²³²⁴

WHEREAS, ADOT is responsible for administering funding to Licensor under the Program; and

²³²⁴ **NOTE TO PROPOSERS:** Add when the Licensor is not the owner of the Property.

WHEREAS, to ensure Licensor’s compliance with the Program, Licensor has agreed to grant access to the Property to ADOT for the purposes of inspecting the Property and inspection of EV Charging Infrastructure, subject to the limitations set forth herein.

NOW, THEREFORE, for and in consideration of the foregoing premises, the mutual covenants and agreements set forth herein, and other good and valuable consideration, the receipt and sufficiency of which is hereby acknowledged, the Licensor and ADOT, intending to be legally bound, do hereby covenant and agree as follows:

1. Grant of License. Subject to and in accordance with the terms and conditions set forth herein, Licensor has the legal authority[, pursuant to the Host Site Agreement or other legal instrument,]²⁴²⁵ to and does hereby grant to ADOT (including ADOT’s employees, agents, contractors and invitees) a nonexclusive right to enter the Property for the purposes of inspection of the EV Charging Infrastructure (the “**License**”).

2. Term of License. This License shall commence on Effective Date and remain in effect until the end of the five year O&M Period (as defined and pursuant to the Project Agreement), unless terminated earlier by the parties (the “**Term**”).

3. Assurances. The Property may be utilized solely by ADOT, and its invitees, for the purposes of inspection of the EV Charging Infrastructure. If ADOT wishes to use the Property for a use not described in this Section 3(a), ADOT will obtain prior written approval from Licensor.

4. Termination of Agreement. This License shall automatically terminate at the expiration of the Term unless renewed by the parties. This License may also be terminated immediately at any time by ADOT upon written notice to the Licensor for any reason including Licensor’s failure to comply with the Project Agreement. Licensor may only terminate this License at the expiration of the Term [or by written notice to ADOT in the event that the Host Site Agreement is terminated]²⁵²⁶.

5. Responsibilities. Subject to Section 6, ADOT will be responsible for its own actions, errors, and omissions as it relates to the terms and conditions set forth in this Agreement. Licensor shall be responsible for its own actions, errors, and omissions as it relates to the terms and conditions set forth in this Agreement.

6. Indemnity. The Licensor shall indemnify, defend and hold harmless the Indemnified Parties (as defined in the Project Agreement) from and against all claims, actions, liabilities, damages, losses, or expenses (including court costs, attorneys’ fees, and costs of claim processing, investigation and litigation) imposed on or incurred by the Indemnified Parties, whether or not arising from third party claims, by reason of any

²⁴²⁵ **NOTE TO PROPOSERS:** Add when the Licensor is not the owner of the Property.

²⁵²⁶ **NOTE TO PROPOSERS:** Add when the Licensor is not the owner of the Property.

exercise by ADOT (or ADOT's employees, agents, contactors or invitees) of ADOT's inspection rights pursuant to Section 1.

7. Assignability. The License is for the sole use of ADOT and its invitees, but ADOT may assign the License or this Agreement and any rights granted herein to any other person or party whomsoever, if first approved by Licensor in writing in Licensor's sole reasonable discretion. Any assignment of this License and Agreement by ADOT without such prior written approval shall be void and of no force or effect.

8. Binding Effect. This Agreement shall be binding upon and shall inure to the benefit of the parties hereto and to the successors and assigns of the parties.

9. Governing Law; Venue. This Agreement shall be construed, interpreted and enforced in accordance with the laws of the State of Arizona. The parties hereby consent to the jurisdiction of the Superior Court located in Maricopa County, Arizona, which shall have exclusive jurisdiction and venue.

10. Notice. All notices, demands and all other communications that may be given to or made by either party to the other in connection with this Agreement shall be delivered in accordance with Section 18.11 of the Project Agreement.

11. Counterparts. This Agreement may be signed in one or more counterparts with the same force and effect as if all signatures were contained in a single original instrument.

12. Authorization. Each of the signatories to this Agreement hereby represents that he or she has the authority to bind their respective entities and that they have undertaken to accomplish any and all actions required by their respective boards, or they have been granted the authority previously by their respective boards to enter into this Agreement.

**(REMAINDER OF PAGE LEFT BLANK INTENTIONALLY. SIGNATURES
CONTAINED ON FOLLOWING PAGE)**

IN WITNESS WHEREOF, the parties hereto have executed this agreement as of the Effective Date.

Unofficial Witness

Sworn to and subscribed before me
this ____ day of _____.

My commission expires: _____

Notary Public

(Notary Seal)

ADOT:
**ARIZONA DEPARTMENT OF
TRANSPORTATION**

By: _____

Signature

Printed Name: Paula Gibson
Title: ADOT Right of Way Administrator

(SEAL)

LICENSOR:

Unofficial Witness ²⁶²⁷

Sworn to and subscribed before me
this _____ day of _____.

My commission expires: _____

Notary Public
(Notary Seal)

By:

Signature

Printed:

Name: _____

Title: _____

—

(CORPORATE SEAL)

²⁶²⁷

NOTE TO PROPOSERS: The Unofficial Witness is not needed if this document is notarized.

APPENDIX A
THE PROPERTY

Exhibit 9

FEDERAL AND STATE REQUIREMENTS

PART A. FEDERAL REQUIREMENTS

- Attachment 1** Federal Requirements for Federal-Aid Construction Facilities
- Attachment 2** Required Contract Provisions, Federal-Aid Construction Contracts - FHWA Form 1273
- Attachment 3** Federal Prevailing Wage Rate
- Attachment 4** Standard Federal Equal Employment Opportunity Construction Contract Specifications (Executive Order 11246) (41 CFR 60-4.3)
- Attachment 5** Certification Regarding Use of Contract Funds for Lobbying
- Attachment 6** Suspension and Debarment Certification
- Attachment 7** Compliance with Buy America and Build America, Buy America Requirements
- Attachment 8** Form 1391 – Federal-Aid Highway Construction Contractors Annual EEO Report
- Attachment 9** [Intentionally Deleted]
- Attachment 10** Title VI Assurances
- Attachment 11** Prohibition on Requiring Certain Internal Confidential Agreements or Statements
- Attachment 12** Additional Requirements

PART B. STATE REQUIREMENTS

- Attachment 1** Participation In Boycott Of Israel Certification Form
- Attachment 2** Forced Labor Of Ethnic Uyghurs Ban Certification Form
- Attachment 3** Immigration Certification Statement

Attachment 1 to Exhibit 9, Part A

FEDERAL REQUIREMENTS FOR FEDERAL-AID CONSTRUCTION FACILITIES

GENERAL. — The work herein proposed will be financed in whole or in part with federal funds, and therefore all of the statutes, rules and regulations promulgated by the federal government and applicable to work financed in whole or in part with federal funds will apply to such work. The “Required Contract Provisions, Federal-Aid Construction Contracts, Form FHWA-1273,” are included in this Exhibit 9, Part A (Federal Requirements).

Whenever in said required contract provisions references are made to:

- (a) “contracting officer,” or “authorized representative,” such references shall be construed to mean ADOT or a duly appointed ADOT representative;
- (b) “contractor,” “prime contractor,” “bidder” or “prospective primary participant,” such references shall be construed to mean the Developer or its authorized representative, as may be appropriate under the circumstances;
- (c) “contract” or “prime contract,” such references shall be construed to mean the Project Agreement;
- (d) “subcontractor,” “supplier,” “vendor,” “prospective lower tier participant” or “lower tier subcontractor,” such references shall be construed to mean, as appropriate, contractors other than the Developer; and
- (e) “department,” “agency” or “department or agency entering into this transaction,” such references shall be construed to mean ADOT, except where a different department or agency is specified.

PERFORMANCE OF PREVIOUS CONTRACT. — In addition to the provisions in Section II, “NONDISCRIMINATION,” and Section VI, “SUBLETTING OR ASSIGNING THE CONTRACT,” of the Form FHWA-1273 required contract provisions, Developer shall cause the contractor to comply with the following:

The bidder shall execute the CERTIFICATION WITH REGARD TO THE PERFORMANCE OF PREVIOUS CONTRACTS OR SUBCONTRACTS SUBJECT TO THE EQUAL OPPORTUNITY CLAUSE AND THE FILING OF REQUIRED REPORTS located in the proposal. No request for subletting or assigning any portion of the contract in excess of \$10,000 will be considered under the provisions of Section VI of the required contract provisions unless such request is accompanied by the CERTIFICATION referred to above, executed by the proposed subcontractor.

NON-COLLUSION PROVISION. — The provisions in this section are applicable to all contracts except contracts for Federal Aid Secondary Projects. Title 23, United States Code, Section 112, requires as a condition precedent to approval by the Federal Highway Administrator of the contract for this work that each bidder file a sworn statement executed by, or on behalf of, the person, firm, association, or corporation to

whom such contract is to be awarded, certifying that such person, firm, association, or corporation has not, either directly or indirectly, entered into any agreement, participated in any collusion, or otherwise taken any action in restraint of free competitive bidding in connection with the submitted bid. The statement shall either be in the form of an affidavit executed and sworn to by the bidder before a person who is authorized by the laws of the State to administer oaths or in the form of an unsworn declaration executed under penalty of perjury of the laws of the United States as permitted by 28 U.S.C. § 1746. A form to make the non-collusion affidavit statement required by 23 U.S.C. § 112 as a certification under penalty of perjury rather than as a sworn statement as permitted by 28 U.S.C. § 1746, is included in the Proposal.

CONVICT PRODUCED MATERIALS

(a) FHWA Federal-aid highway construction projects are subject to 23 CFR 635.417, convict produced materials.

(b) Materials produced after July 1, 1991, by convict labor may only be incorporated in a Federal-aid highway construction project if such materials have been: (i) produced by convicts who are on parole, supervised release, or probation from a prison, or (ii) produced in a qualified prison facility, any prison facility in which convicts, during the 12-month period ending July 1, 1987, produced materials for use in Federal-aid highway construction projects, and the cumulative annual production amount of such materials for use in Federal-aid highway construction does not exceed the amount of such materials produced in such facility for use in Federal-aid highway construction during the 12 month period ending July 1, 1987.

ACCESS TO RECORDS

(a) Developer and its Contractors shall allow FHWA and the Comptroller General of the United States, or their duly authorized representatives, access to all books, documents, papers, and records of Developer and Contractors that are directly pertinent to any grantee or subgrantee contract, for the purpose of making audit, examination, excerpts, and transcriptions thereof. In addition, Developer and its Contractors shall retain all such books, documents, papers, and records for five years after final payment is made pursuant to any such contract and all other pending matters are closed.

(b) Developer agrees to include this section in each Contract at each tier, without modification except as appropriate to identify the Contractor who will be subject to its provisions.

Attachment 2 to Exhibit 9, Part A

Required Contract Provisions

Federal-Aid Construction Contracts

FHWA-1273 – Revised October 23, 2023

- I. General
- II. Nondiscrimination
- III. Non-segregated Facilities IV. Davis-Bacon and Related Act Provisions
- V. Contract Work Hours and Safety Standards Act Provisions
- VI. Subletting or Assigning the Contract
- VII. Safety: Accident Prevention
- VIII. False Statements Concerning Highway Projects IX. Implementation of Clean Air Act and Federal Water Pollution Control Act
- X. Certification Regarding Debarment, Suspension, Ineligibility and Voluntary Exclusion
- XI. Certification Regarding Use of Contract Funds for Lobbying
- XII. Use of United States-Flag Vessels

ATTACHMENTS

- A. Employment and Materials Preference for Appalachian Development Highway System or Appalachian Local Access Road Contracts (included in Appalachian contracts only)

I. GENERAL

1. Form FHWA-1273 must be physically incorporated in each construction contract funded under title 23, United States Code, as required in 23 CFR 633.102(b) (excluding emergency contracts solely intended for debris removal). The contractor (or subcontractor) must insert this form in each subcontract and further require its inclusion in all lower tier subcontracts (excluding purchase orders, rental agreements and other agreements for supplies or services). 23 CFR 633.102(e).

The applicable requirements of Form FHWA-1273 are incorporated by reference for work done under any purchase order, rental agreement or agreement for other services. The prime contractor shall be responsible for compliance by any subcontractor, lower-tier subcontractor or service provider. 23 CFR 633.102(e).

Form FHWA-1273 must be included in all Federal-aid design build contracts, in all subcontracts and in lower tier subcontracts (excluding subcontracts for design services, purchase orders, rental agreements and other agreements for supplies or services) in accordance with 23 CFR 633.102. The design-builder shall be responsible for compliance by any subcontractor, lower-tier subcontractor or service provider.

Contracting agencies may reference Form FHWA-1273 in solicitation-for-bids or request-for-proposals documents, however, the Form FHWA-1273 must be physically incorporated (not referenced) in all contracts, subcontracts and lower-tier subcontracts (excluding purchase orders, rental agreements and other agreements for supplies or services related to a construction contract). 23 CFR 633.102(b).

2. Subject to the applicability criteria noted in the following sections, these contract provisions shall apply to all work performed on the contract by the contractor's own organization and with the assistance of workers under the contractor's immediate superintendence and to all work performed on the contract by piecework, station work, or by subcontract. 23 CFR 633.102(d).

3. A breach of any of the stipulations contained in these Required Contract Provisions may be sufficient grounds for withholding of progress payments, withholding of final payment, termination of the contract, suspension / debarment or any other action determined to be appropriate by the contracting agency and FHWA.

4. Selection of Labor: During the performance of this contract, the contractor shall not use convict labor for any purpose within the limits of a construction project on a Federal-aid highway unless it is labor performed by convicts who are on parole, supervised release, or probation. 23 U.S.C. 114(b). The term Federal-aid highway does not include roadways functionally classified as local roads or rural minor collectors. 23 U.S.C. 101(a).

II. **NONDISCRIMINATION** (23 CFR 230.107(a); 23 CFR Part 230, Subpart A, Appendix A; EO 11246)

The provisions of this section related to 23 CFR Part 230, Subpart A, Appendix A are applicable to all Federal-aid construction contracts and to all related construction subcontracts of \$10,000 or more. The provisions of 23 CFR Part 230 are not applicable to material supply, engineering, or architectural service contracts.

In addition, the contractor and all subcontractors must comply with the following policies: Executive Order 11246, 41 CFR Part 60, 29 CFR Parts 1625-1627, 23 U.S.C. 140, Section 504 of the Rehabilitation Act of 1973, as amended (29 U.S.C. 794), Title VI of the Civil Rights Act of 1964, as amended (42 U.S.C. 2000d et seq.), and related regulations including 49 CFR Parts 21, 26, and 27; and 23 CFR Parts 200, 230, and 633.

The contractor and all subcontractors must comply with: the requirements of the Equal Opportunity Clause in 41 CFR 601.4(b) and, for all construction contracts exceeding \$10,000, the Standard Federal Equal Employment Opportunity Construction Contract Specifications in 41 CFR 60-4.3.

Note: The U.S. Department of Labor has exclusive authority to determine compliance with Executive Order 11246 and the policies of the Secretary of Labor including 41 CFR Part 60, and 29 CFR Parts 1625-1627. The contracting agency and the FHWA have the authority and the responsibility to ensure compliance with 23 U.S.C. 140, Section 504 of the Rehabilitation Act of 1973, as amended (29 U.S.C. 794), and

Title VI of the Civil Rights Act of 1964, as amended (42 U.S.C. 2000d et seq.), and related regulations including 49 CFR Parts 21, 26, and 27; and 23 CFR Parts 200, 230, and 633.

The following provision is adopted from 23 CFR Part 230, Subpart A, Appendix A, with appropriate revisions to conform to the U.S. Department of Labor (US DOL) and FHWA requirements.

1. Equal Employment Opportunity: Equal Employment Opportunity (EEO) requirements not to discriminate and to take affirmative action to assure equal opportunity as set forth under laws, executive orders, rules, regulations (see 28 CFR Part 35, 29 CFR Part 1630, 29 CFR Parts 1625-1627, 41 CFR Part 60 and 49 CFR Part 27) and orders of the Secretary of Labor as modified by the provisions prescribed herein, and imposed pursuant to 23 U.S.C. 140, shall constitute the EEO and specific affirmative action standards for the contractor's project activities under this contract. The provisions of the Americans with Disabilities Act of 1990 (42 U.S.C. 12101 et seq.) set forth under 28 CFR Part 35 and 29 CFR Part 1630 are incorporated by reference in this contract. In the execution of this contract, the contractor agrees to comply with the following minimum specific requirement activities of EEO:

a. The contractor will work with the contracting agency and the Federal Government to ensure that it has made every good faith effort to provide equal opportunity with respect to all of its terms and conditions of employment and in their review of

activities under the contract. 23 CFR 230.409 (g)(4) & (5).

b. The contractor will accept as its operating policy the following statement:

"It is the policy of this Company to assure that applicants are employed, and that employees are treated during employment, without regard to their race, religion, sex, sexual orientation, gender identity, color, national origin, age or disability. Such action shall include: employment, upgrading, demotion, or transfer; recruitment or recruitment advertising; layoff or termination; rates of pay or other forms of compensation; and selection for training, including apprenticeship, pre-apprenticeship, and/or on-the-job training."

2. EEO Officer: The contractor will designate and make known to the contracting officers an EEO Officer who will have the responsibility for and must be capable of effectively administering and promoting an active EEO program and who must be assigned adequate authority and responsibility to do so.

3. Dissemination of Policy: All members of the contractor's staff who are authorized to hire, supervise, promote, and discharge employees, or who recommend such action or are substantially involved in such action, will be made fully cognizant of and will

implement the contractor's EEO policy and contractual responsibilities to provide EEO in each grade and classification of employment. To ensure that the above agreement will be met, the following actions will be taken as a minimum:

a. Periodic meetings of supervisory and personnel office employees will be conducted before the start of work and then not less often than once every six months, at which time the contractor's EEO policy and its implementation will be reviewed and explained. The meetings will be conducted by the EEO Officer or other knowledgeable company official.

b. All new supervisory or personnel office employees will be given a thorough indoctrination by the EEO Officer, covering all major aspects of the contractor's EEO obligations within thirty days following their reporting for duty with the contractor.

c. All personnel who are engaged in direct recruitment for the project will be instructed by the EEO Officer in the contractor's procedures for locating and hiring minorities and women.

d. Notices and posters setting forth the contractor's EEO policy will be placed in areas readily accessible to employees, applicants for employment and potential employees.

e. The contractor's EEO policy and the procedures to implement such policy will be brought to the attention of employees by means of meetings, employee handbooks, or other appropriate means.

4. Recruitment: When advertising for employees, the contractor will include in all advertisements for employees the notation: "An Equal Opportunity Employer." All such advertisements will be placed in publications having a large circulation among minorities and women in the area from which the project work force would normally be derived.

a. The contractor will, unless precluded by a valid bargaining agreement, conduct systematic and direct recruitment through public and private employee referral sources likely to yield qualified minorities and women. To meet this requirement, the contractor will identify sources of potential minority group employees and establish with such identified sources procedures whereby minority and women applicants may be referred to the contractor for employment consideration.

b. In the event the contractor has a valid bargaining agreement providing for exclusive hiring hall referrals, the contractor is expected to observe the provisions of that agreement to the extent that the system meets the contractor's compliance with EEO contract provisions. Where implementation of such an agreement has the effect of discriminating against minorities or women, or obligates the contractor to do the same, such implementation violates Federal nondiscrimination provisions.

c. The contractor will encourage its present employees to refer minorities and women as applicants for employment. Information and procedures with regard to referring

such applicants will be discussed with employees.

5. Personnel Actions: Wages, working conditions, and employee benefits shall be established and administered, and personnel actions of every type, including hiring, upgrading, promotion, transfer, demotion, layoff, and termination, shall be taken without regard to race, color, religion, sex, sexual orientation, gender identity, national origin, age or disability. The following procedures shall be followed:

a. The contractor will conduct periodic inspections of project sites to ensure that working conditions and employee facilities do not indicate discriminatory treatment of project site personnel.

b. The contractor will periodically evaluate the spread of wages paid within each classification to determine any evidence of discriminatory wage practices.

c. The contractor will periodically review selected personnel actions in depth to determine whether there is evidence of discrimination. Where evidence is found, the contractor will promptly take corrective action. If the review indicates that the discrimination may extend beyond the actions reviewed, such corrective action shall include all affected persons.

d. The contractor will promptly investigate all complaints of alleged discrimination made to the contractor in connection with its obligations under this contract, will attempt to resolve such complaints, and will take appropriate corrective action within a reasonable time. If the

investigation indicates that the discrimination may affect persons other than the complainant, such corrective action shall include such other persons. Upon completion of each investigation, the contractor will inform every complainant of all of their avenues of appeal.

6. Training and Promotion:

a. The contractor will assist in locating, qualifying, and increasing the skills of minorities and women who are applicants for employment or current employees. Such efforts should be aimed at developing full journey level status employees in the type of trade or job classification involved.

b. Consistent with the contractor's work force requirements and as permissible under Federal and State regulations, the contractor shall make full use of training programs (i.e., apprenticeship and on-the-job training programs for the geographical area of contract performance). In the event a special provision for training is provided under this contract, this subparagraph will be superseded as indicated in the special provision. The contracting agency may reserve training positions for persons who receive welfare assistance in accordance with 23 U.S.C. 140(a).

c. The contractor will advise employees and applicants for employment of available training programs and entrance requirements for each.

d. The contractor will periodically review the training and promotion potential of employees who are minorities and women and will

encourage eligible employees to apply for such training and promotion.

7. Unions: If the contractor relies in whole or in part upon unions as a source of employees, the contractor will use good faith efforts to obtain the cooperation of such unions to increase opportunities for minorities and women. 23 CFR 230.409. Actions by the contractor, either directly or through a contractor's association acting as agent, will include the procedures set forth below:

a. The contractor will use good faith efforts to develop, in cooperation with the unions, joint training programs aimed toward qualifying more minorities and women for membership in the unions and increasing the skills of minorities and women so that they may qualify for higher paying employment.

b. The contractor will use good faith efforts to incorporate an EEO clause into each union agreement to the end that such union will be contractually bound to refer applicants without regard to their race, color, religion, sex, sexual orientation, gender identity, national origin, age, or disability.

c. The contractor is to obtain information as to the referral practices and policies of the labor union except that to the extent such information is within the exclusive possession of the labor union and such labor union refuses to furnish such information to the contractor, the contractor shall so certify to the contracting agency and shall set forth what efforts have been made to obtain such information.

d. In the event the union is unable to provide the contractor with a reasonable flow of referrals within the time limit set forth in the collective bargaining agreement, the contractor will, through independent recruitment efforts, fill the employment vacancies without regard to race, color, religion, sex, sexual orientation, gender identity, national origin, age, or disability; making full efforts to obtain qualified and/or qualifiable minorities and women. The failure of a union to provide sufficient referrals (even though it is obligated to provide exclusive referrals under the terms of a collective bargaining agreement) does not relieve the contractor from the requirements of this paragraph. In the event the union referral practice prevents the contractor from meeting the obligations pursuant to Executive Order 11246, as amended, and these special provisions, such contractor shall immediately notify the contracting agency.

8. Reasonable Accommodation for Applicants / Employees with Disabilities: The contractor must be familiar with the requirements for and comply with the Americans with Disabilities Act and all rules and regulations established thereunder. Employers must provide reasonable accommodation in all employment activities unless to do so would cause an undue hardship.

9. Selection of Subcontractors, Procurement of Materials and Leasing of Equipment: The contractor shall not discriminate on the grounds of race, color, religion, sex, sexual orientation, gender identity, national origin, age, or disability in the selection and retention of subcontractors, including procurement of materials and

leases of equipment. The contractor shall take all necessary and reasonable steps to ensure nondiscrimination in the administration of this contract.

a. The contractor shall notify all potential subcontractors, suppliers, and lessors of their EEO obligations under this contract.

b. The contractor will use good faith efforts to ensure subcontractor compliance with their EEO obligations.

10. Assurances Required:

a. Reserved.

b. The contractor, subrecipient or subcontractor shall not discriminate on the basis of race, color, national origin, or sex in the performance of this contract. The contractor shall carry out applicable requirements of 49 CFR part 26 in the award and administration of DOT-assisted contracts. Failure by the contractor to carry out these requirements is a material breach of this contract, which may result in the termination of this contract or such other remedy as the recipient deems appropriate, which may include, but is not limited to:

(1) Withholding monthly progress payments;

(2) Assessing sanctions;

(3) Liquidated damages; and/or

(4) Disqualifying the contractor from future bidding as non-responsible.

c. The Title VI and nondiscrimination provisions of U.S. DOT Order 1050.2A at Appendixes A and E are incorporated by reference. 49 CFR Part 21.

11. Records and Reports: The contractor shall keep such records as necessary to document compliance with the EEO requirements. Such records shall be retained for a period of five years following the date of the final payment to the contractor for all contract work and shall be available at reasonable times and places for inspection by authorized representatives of the contracting agency and the FHWA.

a. The records kept by the contractor shall document the following:

(1) The number and work hours of minority and nonminority group members and women employed in each work classification on the project;

(2) The progress and efforts being made in cooperation with unions, when applicable, to increase employment opportunities for minorities and women; and

(3) The progress and efforts being made in locating, hiring, training, qualifying, and upgrading minorities and women.

b. The contractors and subcontractors will submit an annual report to the contracting agency each July for the duration of the project indicating the number of minority, women, and nonminority group employees currently engaged in each work classification required by the contract work. This information is to be

reported on Form FHWA-1391. The staffing data should represent the project work force on board in all or any part of the last payroll period preceding the end of July. If on-the-job training is being required by special provision, the contractor will be required to collect and report training data. The employment data should reflect the work force on board during all or any part of the last payroll period preceding the end of July.

III. NONSEGREGATED FACILITIES

This provision is applicable to all Federal-aid construction contracts and to all related construction subcontracts of more than \$10,000. 41 CFR 60-1.5.

As prescribed by 41 CFR 60-1.8, the contractor must ensure that facilities provided for employees are provided in such a manner that segregation on the basis of race, color, religion, sex, sexual orientation, gender identity, or national origin cannot result. The contractor may neither require such segregated use by written or oral policies nor tolerate such use by employee custom. The contractor's obligation extends further to ensure that its employees are not assigned to perform their services at any location under the contractor's control where the facilities are segregated. The term "facilities" includes waiting rooms, work areas, restaurants and other eating areas, time clocks, restrooms, washrooms, locker rooms and other storage or dressing areas, parking lots, drinking fountains, recreation or entertainment areas, transportation, and housing provided for employees. The contractor shall provide separate or single-user restrooms and necessary dressing or sleeping areas to assure privacy between sexes.

IV. DAVIS-BACON AND RELATED ACT PROVISIONS

This section is applicable to all Federal-aid construction projects exceeding \$2,000 and to all related subcontracts and lower-tier subcontracts (regardless of subcontract size), in accordance with 29 CFR 5.5. The requirements apply to all projects located within the right-of-way of a roadway that is functionally classified as Federal-aid highway. 23 U.S.C. 113. This excludes roadways functionally classified as local roads or rural minor collectors, which are exempt. 23 U.S.C. 101. Where applicable law requires that projects be treated as a project on a Federal-aid highway, the provisions of this subpart will apply regardless of the location of the project. Examples include: Surface Transportation Block Grant Program projects funded under 23 U.S.C. 133 [excluding recreational trails projects], the Nationally Significant Freight and Highway Projects funded under 23 U.S.C. 117, and National Highway Freight Program projects funded under 23 U.S.C. 167.

The following provisions are from the U.S. Department of Labor regulations in 29 CFR 5.5 "Contract provisions and related matters" with minor revisions to conform to the FHWA1273 format and FHWA program requirements.

1. Minimum wages (29 CFR 5.5)

a. Wage rates and fringe benefits. All laborers and mechanics employed or working upon the site of the work (or otherwise working in construction or development of the project under a development statute), will be paid unconditionally and not less often than once a week, and without

subsequent deduction or rebate on any account (except such payroll deductions as are permitted by regulations issued by the Secretary of Labor under the Copeland Act (29 CFR part 3)), the full amount of basic hourly wages and bona fide fringe benefits (or cash equivalents thereof) due at time of payment computed at rates not less than those contained in the wage determination of the Secretary of Labor which is attached hereto and made a part hereof, regardless of any contractual relationship which may be alleged to exist between the contractor and such laborers and mechanics. As provided in paragraphs (d) and (e) of 29 CFR 5.5, the appropriate wage determinations are effective by operation of law even if they have not been attached to the contract. Contributions made or costs reasonably anticipated for bona fide fringe benefits under the Davis-Bacon Act (40 U.S.C. 3141(2)(B)) on behalf of laborers or mechanics are considered wages paid to such laborers or mechanics, subject to the provisions of paragraph 1.e. of this section; also, regular contributions made or costs incurred for more than a weekly period (but not less often than quarterly) under plans, funds, or programs which cover the particular weekly period, are deemed to be constructively made or incurred during such weekly period. Such laborers and mechanics must be paid the appropriate wage rate and fringe benefits on the wage determination for the classification(s) of work actually performed, without regard to skill, except as provided in paragraph 4. of this section. Laborers or mechanics performing work in more than one classification may be compensated at the rate specified for each classification for the time actually

worked therein: Provided, That the employer's payroll records accurately set forth the time spent in each classification in which work is performed. The wage determination (including any additional classifications and wage rates conformed under paragraph 1.c. of this section) and the Davis-Bacon poster (WH-1321) must be posted at all times by the contractor and its subcontractors at the site of the work in a prominent and accessible place where it can be easily seen by the workers.

b. Frequently recurring classifications. (1) In addition to wage and fringe benefit rates that have been determined to be prevailing under the procedures set forth in 29 CFR part 1, a wage determination may contain, pursuant to § 1.3(f), wage and fringe benefit rates for classifications of laborers and mechanics for which conformance requests are regularly submitted pursuant to paragraph 1.c. of this section, provided that:

(i) The work performed by the classification is not performed by a classification in the wage determination for which a prevailing wage rate has been determined;

(ii) The classification is used in the area by the construction industry; and (iii) The wage rate for the classification bears a reasonable relationship to the prevailing wage rates contained in the wage determination.

(2) The Administrator will establish wage rates for such classifications in accordance with paragraph 1.c.(1)(iii) of this section. Work performed in such a classification must be paid at no less than the wage

and fringe benefit rate listed on the wage determination for such classification.

c. *Conformance.* (1) The contracting officer must require that any class of laborers or mechanics, including helpers, which is not listed in the wage determination and which is to be employed under the contract be classified in conformance with the wage determination. Conformance of an additional classification and wage rate and fringe benefits is appropriate only when the following criteria have been met:

(i) The work to be performed by the classification requested is not performed by a classification in the wage determination; and

(ii) The classification is used in the area by the construction industry; and

(iii) The proposed wage rate, including any bona fide fringe benefits, bears a reasonable relationship to the wage rates contained in the wage determination.

(2) The conformance process may not be used to split, subdivide, or otherwise avoid application of classifications listed in the wage determination.

(3) If the contractor and the laborers and mechanics to be employed in the classification (if known), or their representatives, and the contracting officer agree on the classification and wage rate (including the amount designated for fringe benefits where appropriate), a report of the action taken will be sent by the contracting officer by

email to DBAconformance@dol.gov. The Administrator, or an authorized representative, will approve, modify, or disapprove every additional classification action within 30 days of receipt and so advise the contracting officer or will notify the contracting officer within the 30-day period that additional time is necessary.

(4) In the event the contractor, the laborers or mechanics to be employed in the classification or their representatives, and the contracting officer do not agree on the proposed classification and wage rate (including the amount designated for fringe benefits, where appropriate), the contracting officer will, by email to DBAconformance@dol.gov, refer the questions, including the views of all interested parties and the recommendation of the contracting officer, to the Administrator for determination. The Administrator, or an authorized representative, will issue a determination within 30 days of receipt and so advise the contracting officer or will notify the contracting officer within the 30-day period that additional time is necessary.

(5) The contracting officer must promptly notify the contractor of the action taken by the Wage and Hour Division under paragraphs 1.c.(3) and (4) of this section. The contractor must furnish a written copy of such determination to each affected worker or it must be posted as a part of the wage determination. The wage rate (including fringe benefits where appropriate) determined pursuant to paragraph 1.c.(3) or (4) of this section must be paid to all workers performing work in the classification under this contract from

the first day on which work is performed in the classification.

d. *Fringe benefits not expressed as an hourly rate.* Whenever the minimum wage rate prescribed in the contract for a class of laborers or mechanics includes a fringe benefit which is not expressed as an hourly rate, the contractor may either pay the benefit as stated in the wage determination or may pay another bona fide fringe benefit or an hourly cash equivalent thereof.

e. *Unfunded plans.* If the contractor does not make payments to a trustee or other third person, the contractor may consider as part of the wages of any laborer or mechanic the amount of any costs reasonably anticipated in providing bona fide fringe benefits under a plan or program, Provided, That the Secretary of Labor has found, upon the written request of the contractor, in accordance with the criteria set forth in § 5.28, that the applicable standards of the Davis-Bacon Act have been met. The Secretary of Labor may require the contractor to set aside in a separate account assets for the meeting of obligations under the plan or program.

f. *Interest.* In the event of a failure to pay all or part of the wages required by the contract, the contractor will be required to pay interest on any underpayment of wages.

2. Withholding (29 CFR 5.5)

a. *Withholding requirements.* The contracting agency may, upon its own action, or must, upon written request of an authorized representative of the Department of Labor, withhold or

cause to be withheld from the contractor so much of the accrued payments or advances as may be considered necessary to satisfy the liabilities of the prime contractor or any subcontractor for the full amount of wages and monetary relief, including interest, required by the clauses set forth in this section for violations of this contract, or to satisfy any such liabilities required by any other Federal contract, or federally assisted contract subject to Davis-Bacon labor standards, that is held by the same prime contractor (as defined in § 5.2). The necessary funds may be withheld from the contractor under this contract, any other Federal contract with the same prime contractor, or any other federally assisted contract that is subject to Davis-Bacon labor standards requirements and is held by the same prime contractor, regardless of whether the other contract was awarded or assisted by the same agency, and such funds may be used to satisfy the contractor liability for which the funds were withheld. In the event of a contractor's failure to pay any laborer or mechanic, including any apprentice or helper working on the site of the work all or part of the wages required by the contract, or upon the contractor's failure to submit the required records as discussed in paragraph 3.d. of this section, the contracting agency may on its own initiative and after written notice to the contractor, take such action as may be necessary to cause the suspension of any further payment, advance, or guarantee of funds until such violations have ceased.

b. *Priority to withheld funds.* The Department has priority to funds withheld or to be withheld in accordance with paragraph 2.a. of this section or

Section V, paragraph 3.a., or both, over claims to those funds by:

(1) A contractor's surety(ies), including without limitation performance bond sureties and payment bond sureties;

(2) A contracting agency for its procurement costs;

(3) A trustee(s) (either a court-appointed trustee or a U.S. trustee, or both) in bankruptcy of a contractor, or a contractor's bankruptcy estate;

(4) A contractor's assignee(s);

(5) A contractor's successor(s); or

(6) A claim asserted under the Prompt Payment Act, 31 U.S.C. 3901-3907.

3. Records and certified payrolls (29 CFR 5.5)

a. Basic record requirements

(1) *Length of record retention.* All regular payrolls and other basic records must be maintained by the contractor and any subcontractor during the course of the work and preserved for all laborers and mechanics working at the site of the work (or otherwise working in construction or development of the project under a development statute) for a period of at least 3 years after all the work on the prime contract is completed.

(2) *Information required.* Such records must contain the name; Social Security number; last known address, telephone number, and email address of each such worker; each worker's

correct classification(s) of work actually performed; hourly rates of wages paid (including rates of contributions or costs anticipated for bona fide fringe benefits or cash equivalents thereof of the types described in 40 U.S.C. 3141(2)(B) of the Davis-Bacon Act); daily and weekly number of hours actually worked in total and on each covered contract; deductions made; and actual wages paid.

(3) *Additional records relating to fringe benefits.* Whenever the Secretary of Labor has found under paragraph 1.e. of this section that the wages of any laborer or mechanic include the amount of any costs reasonably anticipated in providing benefits under a plan or program described in 40 U.S.C. 3141(2)(B) of the Davis-Bacon Act, the contractor must maintain records which show that the commitment to provide such benefits is enforceable, that the plan or program is financially responsible, and that the plan or program has been communicated in writing to the laborers or mechanics affected, and records which show the costs anticipated or the actual cost incurred in providing such benefits.

(4) *Additional records relating to apprenticeship.* Contractors with apprentices working under approved programs must maintain written evidence of the registration of apprenticeship programs, the registration of the apprentices, and the ratios and wage rates prescribed in the applicable programs.

b. Certified payroll requirements (1) Frequency and method of submission. The contractor or subcontractor must submit weekly, for each week in which any DBA- or

Related Acts covered work is performed, certified payrolls to the contracting agency. The prime contractor is responsible for the submission of all certified payrolls by all subcontractors. A contracting agency or prime contractor may permit or require contractors to submit certified payrolls through an electronic system, as long as the electronic system requires a legally valid electronic signature; the system allows the contractor, the contracting agency, and the Department of Labor to access the certified payrolls upon request for at least 3 years after the work on the prime contract has been completed; and the contracting agency or prime contractor permits other methods of submission in situations where the contractor is unable or limited in its ability to use or access the electronic system.

(2) *Information required.* The certified payrolls submitted must set out accurately and completely all of the information required to be maintained under paragraph 3.a.(2) of this section, except that full Social Security numbers and last known addresses, telephone numbers, and email addresses must not be included on weekly transmittals. Instead, the certified payrolls need only include an individually identifying number for each worker (e.g., the last four digits of the worker’s Social Security number). The required weekly certified payroll information may be submitted using Optional Form WH–347 or in any other format desired. Optional Form WH–347 is available for this purpose from the Wage and Hour Division website at <https://www.dol.gov/sites/dolgov/files/WHD/legacy/files/wh347/.pdf> or its successor website. It is not a violation of this section for a prime contractor to

require a subcontractor to provide full Social Security numbers and last known addresses, telephone numbers, and email addresses to the prime contractor for its own records, without weekly submission by the subcontractor to the contracting agency.

(3) *Statement of Compliance.* Each certified payroll submitted must be accompanied by a “Statement of Compliance,” signed by the contractor or subcontractor, or the contractor’s or subcontractor’s agent who pays or supervises the payment of the persons working on the contract, and must certify the following:

(i) That the certified payroll for the payroll period contains the information required to be provided under paragraph 3.b. of this section, the appropriate information and basic records are being maintained under paragraph 3.a. of this section, and such information and records are correct and complete;

(ii) That each laborer or mechanic (including each helper and apprentice) working on the contract during the payroll period has been paid the full weekly wages earned, without rebate, either directly or indirectly, and that no deductions have been made either directly or indirectly from the full wages earned, other than permissible deductions as set forth in 29 CFR part 3; and (iii) That each laborer or mechanic has been paid not less than the applicable wage rates and fringe benefits or cash equivalents for the classification(s) of work actually performed, as specified in the applicable wage determination incorporated into the contract.

(4) *Use of Optional Form WH-347.* The weekly submission of a properly executed certification set forth on the reverse side of Optional Form WH-347 will satisfy the requirement for submission of the “Statement of Compliance” required by paragraph 3.b.(3) of this section.

(5) *Signature.* The signature by the contractor, subcontractor, or the contractor’s or subcontractor’s agent must be an original handwritten signature or a legally valid electronic signature.

(6) *Falsification.* The falsification of any of the above certifications may subject the contractor or subcontractor to civil or criminal prosecution under 18 U.S.C. 1001 and 31 U.S.C. 3729.

(7) *Length of certified payroll retention.* The contractor or subcontractor must preserve all certified payrolls during the course of the work and for a period of 3 years after all the work on the prime contract is completed.

c. *Contracts, subcontracts, and related documents.* The contractor or subcontractor must maintain this contract or subcontract and related documents including, without limitation, bids, proposals, amendments, modifications, and extensions. The contractor or subcontractor must preserve these contracts, subcontracts, and related documents during the course of the work and for a period of 3 years after all the work on the prime contract is completed.

d. *Required disclosures and access (1) Required record disclosures*

and access to workers. The contractor or subcontractor must make the records required under paragraphs 3.a. through 3.c. of this section, and any other documents that the contracting agency, the State DOT, the FHWA, or the Department of Labor deems necessary to determine compliance with the labor standards provisions of any of the applicable statutes referenced by § 5.1, available for inspection, copying, or transcription by authorized representatives of the contracting agency, the State DOT, the FHWA, or the Department of Labor, and must permit such representatives to interview workers during working hours on the job.

(2) *Sanctions for non-compliance with records and worker access requirements.* If the contractor or subcontractor fails to submit the required records or to make them available, or refuses to permit worker interviews during working hours on the job, the Federal agency may, after written notice to the contractor, sponsor, applicant, owner, or other entity, as the case may be, that maintains such records or that employs such workers, take such action as may be necessary to cause the suspension of any further payment, advance, or guarantee of funds. Furthermore, failure to submit the required records upon request or to make such records available, or to permit worker interviews during working hours on the job, may be grounds for debarment action pursuant to § 5.12. In addition, any contractor or other person that fails to submit the required records or make those records available to WHD within the time WHD requests that the records be produced will be precluded from introducing as evidence in an administrative

proceeding under 29 CFR part 6 any of the required records that were not provided or made available to WHD. WHD will take into consideration a reasonable request from the contractor or person for an extension of the time for submission of records. WHD will determine the reasonableness of the request and may consider, among other things, the location of the records and the volume of production.

(3) *Required information disclosures.* Contractors and subcontractors must maintain the full Social Security number and last known address, telephone number, and email address of each covered worker, and must provide them upon request to the contracting agency, the State DOT, the FHWA, the contractor, or the Wage and Hour Division of the Department of Labor for purposes of an investigation or other compliance action.

4. Apprentices and equal employment opportunity (29 CFR 5.5)

a. *Apprentices (1) Rate of pay.* Apprentices will be permitted to work at less than the predetermined rate for the work they perform when they are employed pursuant to and individually registered in a bona fide apprenticeship program registered with the U.S. Department of Labor, Employment and Training Administration, Office of Apprenticeship (OA), or with a State Apprenticeship Agency recognized by the OA. A person who is not individually registered in the program, but who has been certified by the OA or a State Apprenticeship Agency (where appropriate) to be eligible for probationary employment as an apprentice, will be permitted to work at less than the predetermined rate for the

work they perform in the first 90 days of probationary employment as an apprentice in such a program. In the event the OA or a State Apprenticeship Agency recognized by the OA withdraws approval of an apprenticeship program, the contractor will no longer be permitted to use apprentices at less than the applicable predetermined rate for the work performed until an acceptable program is approved.

(2) *Fringe benefits.* Apprentices must be paid fringe benefits in accordance with the provisions of the apprenticeship program. If the apprenticeship program does not specify fringe benefits, apprentices must be paid the full amount of fringe benefits listed on the wage determination for the applicable classification. If the Administrator determines that a different practice prevails for the applicable apprentice classification, fringe benefits must be paid in accordance with that determination.

(3) *Apprenticeship ratio.* The allowable ratio of apprentices to journeymen on the job site in any craft classification must not be greater than the ratio permitted to the contractor as to the entire work force under the registered program or the ratio applicable to the locality of the project pursuant to paragraph 4.a.(4) of this section. Any worker listed on a payroll at an apprentice wage rate, who is not registered or otherwise employed as stated in paragraph 4.a.(1) of this section, must be paid not less than the applicable wage rate on the wage determination for the classification of work actually performed. In addition, any apprentice performing work on the job site in excess of the ratio permitted under this section must be paid not less

than the applicable wage rate on the wage determination for the work actually performed.

(4) *Reciprocity of ratios and wage rates.* Where a contractor is performing construction on a project in a locality other than the locality in which its program is registered, the ratios and wage rates (expressed in percentages of the journeyworker's hourly rate) applicable within the locality in which the construction is being performed must be observed. If there is no applicable ratio or wage rate for the locality of the project, the ratio and wage rate specified in the contractor's registered program must be observed.

b. *Equal employment opportunity.* The use of apprentices and journeyworkers under this part must be in conformity with the equal employment opportunity requirements of Executive Order 11246, as amended, and 29 CFR part 30.

c. *Apprentices and Trainees (programs of the U.S. DOT).*

Apprentices and trainees working under apprenticeship and skill training programs which have been certified by the Secretary of Transportation as promoting EEO in connection with Federal-aid highway construction programs are not subject to the requirements of paragraph 4 of this Section IV. 23 CFR 230.111(e)(2). The straight time hourly wage rates for apprentices and trainees under such programs will be established by the particular programs. The ratio of apprentices and trainees to journeyworkers shall not be greater than

permitted by the terms of the particular program.

5. Compliance with Copeland Act requirements. The contractor shall comply with the requirements of 29 CFR part 3, which are incorporated by reference in this contract as provided in 29 CFR 5.5.

6. Subcontracts. The contractor or subcontractor must insert FHWA-1273 in any subcontracts, along with the applicable wage determination(s) and such other clauses or contract modifications as the contracting agency may by appropriate instructions require, and a clause requiring the subcontractors to include these clauses and wage determination(s) in any lower tier subcontracts. The prime contractor is responsible for the compliance by any subcontractor or lower tier subcontractor with all the contract clauses in this section. In the event of any violations of these clauses, the prime contractor and any subcontractor(s) responsible will be liable for any unpaid wages and monetary relief, including interest from the date of the underpayment or loss, due to any workers of lower-tier subcontractors, and may be subject to debarment, as appropriate. 29 CFR 5.5.

7. Contract termination: debarment. A breach of the contract clauses in 29 CFR 5.5 may be grounds for termination of the contract, and for debarment as a contractor and a subcontractor as provided in 29 CFR 5.12.

8. Compliance with Davis-Bacon and Related Act requirements. All rulings and interpretations of the Davis-Bacon and Related Acts contained in 29 CFR parts 1, 3, and 5

are herein incorporated by reference in this contract as provided in 29 CFR 5.5.

9. Disputes concerning labor standards. As provided in 29 CFR 5.5, disputes arising out of the labor standards provisions of this contract shall not be subject to the general disputes clause of this contract. Such disputes shall be resolved in accordance with the procedures of the Department of Labor set forth in 29 CFR parts 5, 6, and 7. Disputes within the meaning of this clause include disputes between the contractor (or any of its subcontractors) and the contracting agency, the U.S. Department of Labor, or the employees or their representatives.

10. Certification of eligibility. a. By entering into this contract, the contractor certifies that neither it nor any person or firm who has an interest in the contractor's firm is a person or firm ineligible to be awarded Government contracts by virtue of 40 U.S.C. 3144(b) or § 5.12(a).

b. No part of this contract shall be subcontracted to any person or firm ineligible for award of a Government contract by virtue of 40 U.S.C. 3144(b) or § 5.12(a).

c. The penalty for making false statements is prescribed in the U.S. Code, Title 18 Crimes and Criminal Procedure, 18 U.S.C. 1001.

11. Anti-retaliation. It is unlawful for any person to discharge, demote, intimidate, threaten, restrain, coerce, blacklist, harass, or in any other manner discriminate against, or to cause any person to discharge, demote, intimidate, threaten, restrain, coerce, blacklist,

harass, or in any other manner discriminate against, any worker or job applicant for:

a. Notifying any contractor of any conduct which the worker reasonably believes constitutes a violation of the DBA, Related Acts, this part, or 29 CFR part 1 or 3;

b. Filing any complaint, initiating or causing to be initiated any proceeding, or otherwise asserting or seeking to assert on behalf of themselves or others any right or protection under the DBA, Related Acts, this part, or 29 CFR part 1 or 3;

c. Cooperating in any investigation or other compliance action, or testifying in any proceeding under the DBA, Related Acts, this part, or 29 CFR part 1 or 3; or

d. Informing any other person about their rights under the DBA, Related Acts, this part, or 29 CFR part 1 or 3.

V. CONTRACT WORK HOURS AND SAFETY STANDARDS ACT

Pursuant to 29 CFR 5.5(b), the following clauses apply to any Federal-aid construction contract in an amount in excess of \$100,000 and subject to the overtime provisions of the Contract Work Hours and Safety Standards Act. These clauses shall be inserted in addition to the clauses required by 29 CFR 5.5(a) or 29 CFR 4.6. As used in this paragraph, the terms laborers and mechanics include watchpersons and guards.

1. Overtime requirements. No contractor or subcontractor contracting

for any part of the contract work which may require or involve the employment of laborers or mechanics shall require or permit any such laborer or mechanic in any workweek in which he or she is employed on such work to work in excess of forty hours in such workweek unless such laborer or mechanic receives compensation at a rate not less than one and one-half times the basic rate of pay for all hours worked in excess of forty hours in such workweek. 29 CFR 5.5.

2. Violation; liability for unpaid wages; liquidated damages. In the event of any violation of the clause set forth in paragraph 1. of this section the contractor and any subcontractor responsible therefor shall be liable for the unpaid wages and interest from the date of the underpayment. In addition, such contractor and subcontractor shall be liable to the United States (in the case of work done under contract for the District of Columbia or a territory, to such District or to such territory), for liquidated damages. Such liquidated damages shall be computed with respect to each individual laborer or mechanic, including watchpersons and guards, employed in violation of the clause set forth in paragraph 1. of this section, in the sum currently provided in 29 CFR 5.5(b)(2)* for each calendar day on which such individual was required or permitted to work in excess of the standard workweek of forty hours without payment of the overtime wages required by the clause set forth in paragraph 1. of this section.

* \$31 as of January 15, 2023 (See 88 FR 88 FR 2210) as may be adjusted annually by the Department of Labor,

pursuant to the Federal Civil Penalties Inflation Adjustment Act of 1990.

3. Withholding for unpaid wages and liquidated damages

a. Withholding process. The FHWA or the contracting agency may, upon its own action, or must, upon written request of an authorized representative of the Department of Labor, withhold or cause to be withheld from the contractor so much of the accrued payments or advances as may be considered necessary to satisfy the liabilities of the prime contractor or any subcontractor for any unpaid wages; monetary relief, including interest; and liquidated damages required by the clauses set forth in this section on this contract, any other Federal contract with the same prime contractor, or any other federally assisted contract subject to the Contract Work Hours and Safety Standards Act that is held by the same prime contractor (as defined in § 5.2). The necessary funds may be withheld from the contractor under this contract, any other Federal contract with the same prime contractor, or any other federally assisted contract that is subject to the Contract Work Hours and Safety Standards Act and is held by the same prime contractor, regardless of whether the other contract was awarded or assisted by the same agency, and such funds may be used to satisfy the contractor liability for which the funds were withheld.

b. Priority to withheld funds. The Department has priority to funds withheld or to be withheld in accordance with Section IV paragraph 2.a. or paragraph 3.a. of this section, or both, over claims to those funds by:

(1) A contractor's surety(ies), including without limitation performance bond sureties and payment bond sureties;

(2) A contracting agency for its procurement costs;

(3) A trustee(s) (either a court-appointed trustee or a U.S. trustee, or both) in bankruptcy of a contractor, or a contractor's bankruptcy estate;

(4) A contractor's assignee(s);

(5) A contractor's successor(s); or

(6) A claim asserted under the Prompt Payment Act, 31 U.S.C. 3901–3907.

4. Subcontracts. The contractor or subcontractor must insert in any subcontracts the clauses set forth in paragraphs 1. through 5. of this section and a clause requiring the subcontractors to include these clauses in any lower tier subcontracts. The prime contractor is responsible for compliance by any subcontractor or lower tier subcontractor with the clauses set forth in paragraphs 1. through 5. In the event of any violations of these clauses, the prime contractor and any subcontractor(s) responsible will be liable for any unpaid wages and monetary relief, including interest from the date of the underpayment or loss, due to any workers of lower tier subcontractors, and associated liquidated damages and may be subject to debarment, as appropriate.

5. Anti-retaliation. It is unlawful for any person to discharge, demote,

intimidate, threaten, restrain, coerce, blacklist, harass, or in any other manner discriminate against, or to cause any person to discharge, demote, intimidate, threaten, restrain, coerce, blacklist, harass, or in any other manner discriminate against, any worker or job applicant for:

a. Notifying any contractor of any conduct which the worker reasonably believes constitutes a violation of the Contract Work Hours and Safety Standards Act (CWHSSA) or its implementing regulations in this part;

b. Filing any complaint, initiating or causing to be initiated any proceeding, or otherwise asserting or seeking to assert on behalf of themselves or others any right or protection under CWHSSA or this part;

c. Cooperating in any investigation or other compliance action, or testifying in any proceeding under CWHSSA or this part; or

d. Informing any other person about their rights under CWHSSA or this part.

VI. SUBLETTING OR ASSIGNING THE CONTRACT

This provision is applicable to all Federal-aid construction contracts on the National Highway System pursuant to 23 CFR 635.116.

1. The contractor shall perform with its own organization contract work amounting to not less than 30 percent (or a greater percentage if specified elsewhere in the contract) of the total original contract price, excluding any specialty items designated by the

contracting agency. Specialty items may be performed by subcontract and the amount of any such specialty items performed may be deducted from the total original contract price before computing the amount of work required to be performed by the contractor's own organization (23 CFR 635.116).

a. The term "perform work with its own organization" in paragraph 1 of Section VI refers to workers employed or leased by the prime contractor, and equipment owned or rented by the prime contractor, with or without operators. Such term does not include employees or equipment of a subcontractor or lower tier subcontractor, agents of the prime contractor, or any other assignees. The term may include payments for the costs of hiring leased employees from an employee leasing firm meeting all relevant Federal and State regulatory requirements. Leased employees may only be included in this term if the prime contractor meets all of the following conditions: (based on longstanding interpretation)

(1) the prime contractor maintains control over the supervision of the day-to-day activities of the leased employees;

(2) the prime contractor remains responsible for the quality of the work of the leased employees;

(3) the prime contractor retains all power to accept or exclude individual employees from work on the project; and

(4) the prime contractor remains ultimately responsible for the payment of predetermined minimum

wages, the submission of payrolls, statements of compliance and all other Federal regulatory requirements.

b. "Specialty Items" shall be construed to be limited to work that requires highly specialized knowledge, abilities, or equipment not ordinarily available in the type of contracting organizations qualified and expected to bid or propose on the contract as a whole and in general are to be limited to minor components of the overall contract. 23 CFR 635.102.

2. Pursuant to 23 CFR 635.116(a), the contract amount upon which the requirements set forth in paragraph (1) of Section VI is computed includes the cost of material and manufactured products which are to be purchased or produced by the contractor under the contract provisions.

3. Pursuant to 23 CFR 635.116(c), the contractor shall furnish (a) a competent superintendent or supervisor who is employed by the firm, has full authority to direct performance of the work in accordance with the contract requirements, and is in charge of all construction operations (regardless of who performs the work) and (b) such other of its own organizational resources (supervision, management, and engineering services) as the contracting officer determines is necessary to assure the performance of the contract.

4. No portion of the contract shall be sublet, assigned or otherwise disposed of except with the written consent of the contracting officer, or authorized representative, and such consent when given shall not be construed to relieve the contractor of

any responsibility for the fulfillment of the contract. Written consent will be given only after the contracting agency has assured that each subcontract is evidenced in writing and that it contains all pertinent provisions and requirements of the prime contract. (based on longstanding interpretation of 23 CFR 635.116).

5. The 30-percent self-performance requirement of paragraph (1) is not applicable to design-build contracts; however, contracting agencies may establish their own self-performance requirements. 23 CFR 635.116(d).

VII. SAFETY: ACCIDENT PREVENTION

This provision is applicable to all Federal-aid construction contracts and to all related subcontracts.

1. In the performance of this contract the contractor shall comply with all applicable Federal, State, and local laws governing safety, health, and sanitation (23 CFR Part 635). The contractor shall provide all safeguards, safety devices and protective equipment and take any other needed actions as it determines, or as the contracting officer may determine, to be reasonably necessary to protect the life and health of employees on the job and the safety of the public and to protect property in connection with the performance of the work covered by the contract. 23 CFR 635.108.

2. It is a condition of this contract, and shall be made a condition of each subcontract, which the contractor enters into pursuant to this contract, that the contractor and any subcontractor shall not permit any employee, in

performance of the contract, to work in surroundings or under conditions which are unsanitary, hazardous or dangerous to his/her health or safety, as determined under construction safety and health standards (29 CFR Part 1926) promulgated by the Secretary of Labor, in accordance with Section 107 of the Contract Work Hours and Safety Standards Act (40 U.S.C.3704). 29 CFR 1926.10.

3. Pursuant to 29 CFR 1926.3, it is a condition of this contract that the Secretary of Labor or authorized representative thereof, shall have right of entry to any site of contract performance to inspect or investigate the matter of compliance with the construction safety and health standards and to carry out the duties of the Secretary under Section 107 of the Contract Work Hours and Safety Standards Act (40 U.S.C. 3704).

VIII. FALSE STATEMENTS CONCERNING HIGHWAY PROJECTS

This provision is applicable to all Federal-aid construction contracts and to all related subcontracts.

In order to assure high quality and durable construction in conformity with approved plans and specifications and a high degree of reliability on statements and representations made by engineers, contractors, suppliers, and workers on Federal-aid highway projects, it is essential that all persons concerned with the project perform their functions as carefully, thoroughly, and honestly as possible. Willful falsification, distortion, or misrepresentation with respect to any facts related to the project is a violation of Federal law. To prevent any misunderstanding regarding the

seriousness of these and similar acts, Form FHWA-1022 shall be posted on each Federal-aid highway project (23 CFR Part 635) in one or more places where it is readily available to all persons concerned with the project:

18 U.S.C. 1020 reads as follows:

“Whoever, being an officer, agent, or employee of the United States, or of any State or Territory, or whoever, whether a person, association, firm, or corporation, knowingly makes any false statement, false representation, or false report as to the character, quality, quantity, or cost of the material used or to be used, or the quantity or quality of the work performed or to be performed, or the cost thereof in connection with the submission of plans, maps, specifications, contracts, or costs of construction on any highway or related project submitted for approval to the Secretary of Transportation; or Whoever knowingly makes any false statement, false representation, false report or false claim with respect to the character, quality, quantity, or cost of any work performed or to be performed, or materials furnished or to be furnished, in connection with the construction of any highway or related project approved by the Secretary of Transportation; or Whoever knowingly makes any false statement or false representation as to material fact in any statement, certificate, or report submitted pursuant to provisions of the Federal-aid Roads Act approved July 11, 1916, (39 Stat. 355), as amended and supplemented;

Shall be fined under this title or imprisoned not more than 5 years or both.”

IX. IMPLEMENTATION OF CLEAN AIR ACT AND FEDERAL WATER POLLUTION CONTROL ACT (42 U.S.C. 7606; 2 CFR 200.88; EO 11738)

This provision is applicable to all Federal-aid construction contracts in excess of \$150,000 and to all related subcontracts. 48 CFR 2.101; 2 CFR 200.327.

By submission of this bid/proposal or the execution of this contract or subcontract, as appropriate, the bidder, proposer, Federal-aid construction contractor, subcontractor, supplier, or vendor agrees to comply with all applicable standards, orders or regulations issued pursuant to the Clean Air Act (42 U.S.C. 7401-7671q) and the Federal Water Pollution Control Act, as amended (33 U.S.C. 1251-1387). Violations must be reported to the Federal Highway Administration and the Regional Office of the Environmental Protection Agency. 2 CFR Part 200, Appendix II.

The contractor agrees to include or cause to be included the requirements of this Section in every subcontract, and further agrees to take such action as the contracting agency may direct as a means of enforcing such requirements. 2 CFR 200.327.

X. CERTIFICATION REGARDING DEBARMENT, SUSPENSION, INELIGIBILITY AND VOLUNTARY EXCLUSION

This provision is applicable to all Federal-aid construction contracts, design-build contracts, subcontracts, lower-tier subcontracts, purchase orders, lease agreements, consultant contracts or any other covered

transaction requiring FHWA approval or that is estimated to cost \$25,000 or more – as defined in 2 CFR Parts 180 and 1200. 2 CFR 180.220 and 1200.220.

1. Instructions for Certification – First Tier Participants:

a. By signing and submitting this proposal, the prospective first tier participant is providing the certification set out below.

b. The inability of a person to provide the certification set out below will not necessarily result in denial of participation in this covered transaction. The prospective first tier participant shall submit an explanation of why it cannot provide the certification set out below. The certification or explanation will be considered in connection with the department or agency’s determination whether to enter into this transaction. However, failure of the prospective first tier participant to furnish a certification or an explanation shall disqualify such a person from participation in this transaction. 2 CFR 180.320.

c. The certification in this clause is a material representation of fact upon which reliance was placed when the contracting agency determined to enter into this transaction. If it is later determined that the prospective participant knowingly rendered an erroneous certification, in addition to other remedies available to the Federal Government, the contracting agency may terminate this transaction for cause of default. 2 CFR 180.325.

d. The prospective first tier participant shall provide immediate

written notice to the contracting agency to whom this proposal is submitted if any time the prospective first tier participant learns that its certification was erroneous when submitted or has become erroneous by reason of changed circumstances. 2 CFR 180.345 and 180.350.

e. The terms “covered transaction,” “debarred,” “suspended,” “ineligible,” “participant,” “person,” “principal,” and “voluntarily excluded,” as used in this clause, are defined in 2 CFR Parts 180, Subpart I, 180.900-180.1020, and 1200. “First Tier Covered Transactions” refers to any covered transaction between a recipient or subrecipient of Federal funds and a participant (such as the prime or general contract). “Lower Tier Covered Transactions” refers to any covered transaction under a First Tier Covered Transaction (such as subcontracts). “First Tier Participant” refers to the participant who has entered into a covered transaction with a recipient or subrecipient of Federal funds (such as the prime or general contractor). “Lower Tier Participant” refers any participant who has entered into a covered transaction with a First Tier Participant or other Lower Tier Participants (such as subcontractors and suppliers).

f. The prospective first tier participant agrees by submitting this proposal that, should the proposed covered transaction be entered into, it shall not knowingly enter into any lower tier covered transaction with a person who is debarred, suspended, declared ineligible, or voluntarily excluded from participation in this covered transaction, unless authorized by the department or

agency entering into this transaction. 2 CFR 180.330.

g. The prospective first tier participant further agrees by submitting this proposal that it will include the clause titled “Certification Regarding Debarment, Suspension, Ineligibility and Voluntary Exclusion-Lower Tier Covered Transactions,” provided by the department or contracting agency, entering into this covered transaction, without modification, in all lower tier covered transactions and in all solicitations for lower tier covered transactions exceeding the \$25,000 threshold. 2 CFR 180.220 and 180.300.

h. A participant in a covered transaction may rely upon a certification of a prospective participant in a lower tier covered transaction that is not debarred, suspended, ineligible, or voluntarily excluded from the covered transaction, unless it knows that the certification is erroneous. 2 CFR 180.300; 180.320, and 180.325. A participant is responsible for ensuring that its principals are not suspended, debarred, or otherwise ineligible to participate in covered transactions. 2 CFR 180.335. To verify the eligibility of its principals, as well as the eligibility of any lower tier prospective participants, each participant may, but is not required to, check the System for Award Management website (<https://www.sam.gov/>). 2 CFR 180.300, 180.320, and 180.325.

i. Nothing contained in the foregoing shall be construed to require the establishment of a system of records in order to render in good faith the certification required by this clause. The knowledge and information of the prospective participant is not required to

exceed that which is normally possessed by a prudent person in the ordinary course of business dealings.

j. Except for transactions authorized under paragraph (f) of these instructions, if a participant in a covered transaction knowingly enters into a lower tier covered transaction with a person who is suspended, debarred, ineligible, or voluntarily excluded from participation in this transaction, in addition to other remedies available to the Federal Government, the department or agency may terminate this transaction for cause or default. 2 CFR 180.325.

2. Certification Regarding Debarment, Suspension, Ineligibility and Voluntary Exclusion – First Tier Participants:

a. The prospective first tier participant certifies to the best of its knowledge and belief, that it and its principals:

(1) Are not presently debarred, suspended, proposed for debarment, declared ineligible, or voluntarily excluded from participating in covered transactions by any Federal department or agency, 2 CFR 180.335;.

(2) Have not within a three-year period preceding this proposal been convicted of or had a civil judgment rendered against them for commission of fraud or a criminal offense in connection with obtaining, attempting to obtain, or performing a public (Federal, State, or local) transaction or contract under a public transaction; violation of Federal or State antitrust statutes or commission of embezzlement, theft, forgery, bribery,

falsification or destruction of records, making false statements, or receiving stolen property, 2 CFR 180.800;

(3) Are not presently indicted for or otherwise criminally or civilly charged by a governmental entity (Federal, State or local) with commission of any of the offenses enumerated in paragraph (a)(2) of this certification, 2 CFR 180.700 and 180.800; and

(4) Have not within a three-year period preceding this application/proposal had one or more public transactions (Federal, State or local) terminated for cause or default. 2 CFR 180.335(d).

(5) Are not a corporation that has been convicted of a felony violation under any Federal law within the two-year period preceding this proposal (USDOT Order 4200.6 implementing appropriations act requirements); and

(6) Are not a corporation with any unpaid Federal tax liability that has been assessed, for which all judicial and administrative remedies have been exhausted, or have lapsed, and that is not being paid in a timely manner pursuant to an agreement with the authority responsible for collecting the tax liability (USDOT Order 4200.6 implementing appropriations act requirements).

b. Where the prospective participant is unable to certify to any of the statements in this certification, such prospective participant should attach an explanation to this proposal. 2 CFR 180.335 and 180.340.

3. Instructions for Certification - Lower Tier Participants:

(Applicable to all subcontracts, purchase orders, and other lower tier transactions requiring prior FHWA approval or estimated to cost \$25,000 or more - 2 CFR Parts 180 and 1200). 2 CFR 180.220 and 1200.220.

a. By signing and submitting this proposal, the prospective lower tier participant is providing the certification set out below.

b. The certification in this clause is a material representation of fact upon which reliance was placed when this transaction was entered into. If it is later determined that the prospective lower tier participant knowingly rendered an erroneous certification, in addition to other remedies available to the Federal Government, the department, or agency with which this transaction originated may pursue available remedies, including suspension and/or debarment.

c. The prospective lower tier participant shall provide immediate written notice to the person to which this proposal is submitted if at any time the prospective lower tier participant learns that its certification was erroneous by reason of changed circumstances. 2 CFR 180.365.

d. The terms “covered transaction,” “debarred,” “suspended,” “ineligible,” “participant,” “person,” “principal,” and “voluntarily excluded,” as used in this clause, are defined in 2 CFR Parts 180, Subpart I, 180.900 – 180.1020, and 1200. You may contact the person to which this proposal is submitted for assistance in obtaining a

copy of those regulations. “First Tier Covered Transactions” refers to any covered transaction between a recipient or subrecipient of Federal funds and a participant (such as the prime or general contract). “Lower Tier Covered Transactions” refers to any covered transaction under a First Tier Covered Transaction (such as subcontracts). “First Tier Participant” refers to the participant who has entered into a covered transaction with a recipient or subrecipient of Federal funds (such as the prime or general contractor). “Lower Tier Participant” refers any participant who has entered into a covered transaction with a First Tier Participant or other Lower Tier Participants (such as subcontractors and suppliers).

e. The prospective lower tier participant agrees by submitting this proposal that, should the proposed covered transaction be entered into, it shall not knowingly enter into any lower tier covered transaction with a person who is debarred, suspended, declared ineligible, or voluntarily excluded from participation in this covered transaction, unless authorized by the department or agency with which this transaction originated. 2 CFR 1200.220 and 1200.332.

f. The prospective lower tier participant further agrees by submitting this proposal that it will include this clause titled “Certification Regarding Debarment, Suspension, Ineligibility and Voluntary Exclusion-Lower Tier Covered Transaction,” without modification, in all lower tier covered transactions and in all solicitations for lower tier covered transactions exceeding the \$25,000 threshold. 2 CFR 180.220 and 1200.220.

g. A participant in a covered transaction may rely upon a certification of a prospective participant in a lower tier covered transaction that is not debarred, suspended, ineligible, or voluntarily excluded from the covered transaction, unless it knows that the certification is erroneous. A participant is responsible for ensuring that its principals are not suspended, debarred, or otherwise ineligible to participate in covered transactions. To verify the eligibility of its principals, as well as the eligibility of any lower tier prospective participants, each participant may, but is not required to, check the System for Award Management website (<https://www.sam.gov/>), which is compiled by the General Services Administration. 2 CFR 180.300, 180.320, 180.330, and 180.335.

h. Nothing contained in the foregoing shall be construed to require establishment of a system of records in order to render in good faith the certification required by this clause. The knowledge and information of participant is not required to exceed that which is normally possessed by a prudent person in the ordinary course of business dealings.

i. Except for transactions authorized under paragraph e of these instructions, if a participant in a covered transaction knowingly enters into a lower tier covered transaction with a person who is suspended, debarred, ineligible, or voluntarily excluded from participation in this transaction, in addition to other remedies available to the Federal Government, the department or agency with which this transaction originated may pursue available remedies, including

suspension and/or debarment. 2 CFR 180.325.

* * * * *

4. Certification Regarding Debarment, Suspension, Ineligibility and Voluntary Exclusion--Lower Tier Participants:

a. The prospective lower tier participant certifies, by submission of this proposal, that neither it nor its principals:

(1) is presently debarred, suspended, proposed for debarment, declared ineligible, or voluntarily excluded from participating in covered transactions by any Federal department or agency, 2 CFR 180.355;

(2) is a corporation that has been convicted of a felony violation under any Federal law within the two-year period preceding this proposal (USDOT Order 4200.6 implementing appropriations act requirements); and

(3) is a corporation with any unpaid Federal tax liability that has been assessed, for which all judicial and administrative remedies have been exhausted, or have lapsed, and that is not being paid in a timely manner pursuant to an agreement with the authority responsible for collecting the tax liability. (USDOT Order 4200.6 implementing appropriations act requirements)

b. Where the prospective lower tier participant is unable to certify to any of the statements in this certification, such prospective participant should attach an explanation to this proposal.

* * * * *

XI. CERTIFICATION REGARDING USE OF CONTRACT FUNDS FOR LOBBYING

This provision is applicable to all Federal-aid construction contracts and to all related subcontracts which exceed \$100,000. 49 CFR Part 20, App. A.

1. The prospective participant certifies, by signing and submitting this bid or proposal, to the best of his or her knowledge and belief, that:

a. No Federal appropriated funds have been paid or will be paid, by or on behalf of the undersigned, to any person for influencing or attempting to influence an officer or employee of any Federal agency, a Member of Congress, an officer or employee of Congress, or an employee of a Member of Congress in connection with the awarding of any Federal contract, the making of any Federal grant, the making of any Federal loan, the entering into of any cooperative agreement, and the extension, continuation, renewal, amendment, or modification of any Federal contract, grant, loan, or cooperative agreement.

b. If any funds other than Federal appropriated funds have been paid or will be paid to any person for influencing or attempting to influence an officer or employee of any Federal agency, a Member of Congress, an officer or employee of Congress, or an employee of a Member of Congress in connection with this Federal contract, grant, loan, or cooperative agreement, the undersigned shall complete and submit Standard Form-LLL, "Disclosure

Form to Report Lobbying,” in accordance with its instructions.

2. This certification is a material representation of fact upon which reliance was placed when this transaction was made or entered into. Submission of this certification is a prerequisite for making or entering into this transaction imposed by 31 U.S.C. 1352. Any person who fails to file the required certification shall be subject to a civil penalty of not less than \$10,000 and not more than \$100,000 for each such failure.

3. The prospective participant also agrees by submitting its bid or proposal that the participant shall require that the language of this certification be included in all lower tier subcontracts, which exceed \$100,000 and that all such recipients shall certify and disclose accordingly.

XII. USE OF UNITED STATES-FLAG VESSELS

This provision is applicable to all Federal-aid construction contracts, design-build contracts, subcontracts, lower-tier subcontracts, purchase orders, lease agreements, or any other covered transaction. 46 CFR Part 381.

This requirement applies to material or equipment that is acquired for a specific Federal-aid highway project. 46 CFR 381.7. It is not applicable to goods or materials that come into inventories independent of an FHWA funded-contract. When oceanic shipments (or shipments across the Great Lakes) are necessary for materials or equipment acquired for a specific Federal-aid construction project,

the bidder, proposer, contractor, subcontractor, or vendor agrees:

1. To utilize privately owned United States-flag commercial vessels to ship at least 50 percent of the gross tonnage (computed separately for dry bulk carriers, dry cargo liners, and tankers) involved, whenever shipping any equipment, material, or commodities pursuant to this contract, to the extent such vessels are available at fair and reasonable rates for United States-flag commercial vessels. 46 CFR 381.7.

2. To furnish within 20 days following the date of loading for shipments originating within the United States or within 30 working days following the date of loading for shipments originating outside the United States, a legible copy of a rated, ‘on-board’ commercial ocean bill-of-lading in English for each shipment of cargo described in paragraph (b)(1) of this section to both the Contracting Officer (through the prime contractor in the case of subcontractor bills-of-lading) and to the Office of Cargo and Commercial Sealift (MAR-620), Maritime Administration, Washington, DC 20590. (MARAD requires copies of the ocean carrier’s (master) bills of lading, certified onboard, dated, with rates and charges. These bills of lading may contain business sensitive information and therefore may be submitted directly to MARAD by the Ocean Transportation Intermediary on behalf of the contractor). 46 CFR 381.7.

ATTACHMENT A - EMPLOYMENT AND MATERIALS PREFERENCE FOR APPALACHIAN DEVELOPMENT HIGHWAY SYSTEM OR APPALACHIAN LOCAL ACCESS ROAD CONTRACTS

(23 CFR 633, Subpart B, Appendix B)
This provision is applicable to all Federal-aid projects funded under the Appalachian Regional Development Act of 1965.

1. During the performance of this contract, the contractor undertaking to do work which is, or reasonably may be, done as on-site work, shall give preference to qualified persons who regularly reside in the labor area as designated by the DOL wherein the contract work is situated, or the subregion, or the Appalachian counties of the State wherein the contract work is situated, except:

a. To the extent that qualified persons regularly residing in the area are not available.

b. For the reasonable needs of the contractor to employ supervisory or specially experienced personnel necessary to assure an efficient execution of the contract work.

c. For the obligation of the contractor to offer employment to present or former employees as the result of a lawful collective bargaining contract, provided that the number of nonresident persons employed under this subparagraph (1c) shall not exceed 20 percent of the total number of employees employed by the contractor on the contract work, except as provided in subparagraph (4) below.

2. The contractor shall place a job order with the State Employment Service indicating (a) the classifications of the laborers, mechanics and other employees required to perform the contract work, (b) the number of employees required in each classification, (c) the date on which the participant estimates such employees will be required, and (d) any other pertinent information required by the State Employment Service to complete the job order form. The job order may be placed with the State Employment Service in writing or by telephone. If during the course of the contract work, the information submitted by the contractor in the original job order is substantially modified, the participant shall promptly notify the State Employment Service.

3. The contractor shall give full consideration to all qualified job applicants referred to him by the State Employment Service. The contractor is not required to grant employment to any job applicants who, in his opinion, are not qualified to perform the classification of work required.

4. If, within one week following the placing of a job order by the contractor with the State Employment Service, the State Employment Service is unable to refer any qualified job applicants to the contractor, or less than the number requested, the State Employment Service will forward a certificate to the contractor indicating the unavailability of applicants. Such certificate shall be made a part of the contractor's permanent project records. Upon receipt of this certificate, the contractor may employ persons who do not normally reside in the labor area to fill positions covered by the certificate,

notwithstanding the provisions of subparagraph (1c) above.

5. The provisions of 23 CFR 633.207(e) allow the contracting agency to provide a contractual preference for

the use of mineral resource materials native to the Appalachian region.

6. The contractor shall include the provisions of Sections 1 through 4 of this Attachment A in every subcontract for work which is, or reasonably may be, done as on-site work.

Attachment 3 to Exhibit 9, Part A
FEDERAL PREVAILING WAGE RATE
(Subject to change)
(Attached)

Superseded General Decision Number: AZ20230008

State: Arizona

Construction Type: Highway

Counties: Coconino, Maricopa, Mohave, Pima, Pinal, Yavapai and Yuma Counties in Arizona.

HIGHWAY CONSTRUCTION PROJECTS

Note: Contracts subject to the Davis-Bacon Act are generally required to pay at least the applicable minimum wage rate required under Executive Order 14026 or Executive Order 13658. Please note that these Executive Orders apply to covered contracts entered into by the federal government that are subject to the Davis-Bacon Act itself, but do not apply to contracts subject only to the Davis-Bacon Related Acts, including those set forth at 29 CFR 5.1(a)(1).

If the contract is entered into on or after January 30, 2022, or the contract is renewed or extended (e.g., an option is exercised) on or after January 30, 2022:	<ul style="list-style-type: none">. Executive Order 14026 generally applies to the contract.. The contractor must pay all covered workers at least \$17.20 per hour (or the applicable wage rate listed on this wage determination, if it is higher) for all hours spent performing on the contract in 2024.
If the contract was awarded on or between January 1, 2015 and January 29, 2022, and the contract is not renewed or extended on or after January 30, 2022:	<ul style="list-style-type: none">. Executive Order 13658 generally applies to the contract.. The contractor must pay all covered workers at least \$12.90 per hour (or the applicable wage rate listed on this wage determination, if it is higher) for all hours spent performing on that contract in 2024.

The applicable Executive Order minimum wage rate will be adjusted annually. If this contract is covered by one of the Executive Orders and a classification considered necessary for performance of work on the contract does not appear on this wage determination, the contractor must still submit a conformance request.

Additional information on contractor requirements and worker protections under the Executive Orders is available at <http://www.dol.gov/whd/govcontracts>.

CARP0408-005 07/01/2023

	Rates	Fringes
CARPENTER (Including Cement Form Work).....	\$ 34.50	14.17

ENGI0428-001 06/01/2023

	Rates	Fringes
POWER EQUIPMENT OPERATOR		
Group 1.....	\$ 31.69	13.52
Group 2.....	\$ 34.96	13.52
Group 3.....	\$ 36.04	13.52
Group 4.....	\$ 37.07	13.52

POWER EQUIPMENT OPERATORS CLASSIFICATIONS:

GROUP 1: A-frame boom truck, air compressor, Beltcrete, boring bridge and texture, brakeman, concrete mixer (skip type), conductor, conveyor, cross timing and pipe float, curing machine, dinky (under 20 tons), elevator hoist (Husky and similar), firemen, forklift, generator (all), handler, highline cableway signalman, hydrographic mulcher, joint inserter, jumbo finishing machine, Kolman belt loader, machine conveyor, multiple power concrete saw, pavement breaker, power grizzly, pressure grout machine, pump, self-propelled chip spreading machine, slurry seal machine (Moto paver driver), small self-propelled compactor (with blade-backfill, ditch operation), straw blower, tractor (wheel type), tripper, tugger (single drum), welding machine, winch truck

GROUP 2:
ALL COUNTIES INCLUDING MARICOPA: Aggregate Plant, Asphalt plant Mixer, Bee Gee, Boring Machine, Concrete Pump, Concrete Mechanical Tamping-Spreading Finishing Machine, Concrete Batch Plant, Concrete Mixer (paving & mobile), Elevating Grader (except as otherwise classified), Field Equipment Serviceman, Locomotive Engineer (including Dinky 20 tons & over), Moto-Paver, Oiler-Driver, Operating Engineer Rigger, Power Jumbo Form Setter, Road Oil Mixing Machine, Self-Propelled Compactor (with blade-grade operation), Slip Form (power driven lifting device for concrete forms), Soil Cement Road Mixing Machine, Pipe-Wrapping & Cleaning Machine (stationary or traveling), Surface Heater & Planer, Trenching Machine, Tugger (2 or more drums).

MARICOPA COUNTY ONLY: Backhoe < 1 cu yd, Motor Grader (rough), Scraper (pneumatic tired), Roller (all types asphalt), Screed, Skip Loader (all types 3<6 cu yd), Tractor (dozer, pusher-all).

GROUP 3:
ALL COUNTIES INCLUDING MARICOPA: Auto Grade Machine, Barge, Boring Machine (including Mole, Badger & similar type directional/horizontal), Crane (crawler & pneumatic 15>100 tons), Crawler type Tractor with boom attachment & slope bar, Derrick, Gradall, Heavy Duty Mechanic-Welder, Helicopter Hoist or Pilot, Highline Cableway, Mechanical Hoist, Mucking Machine, Overhead Crane, Pile Driver

Engineer (portable, stationary or skid), Power Driven Ditch Lining or Ditch Trimming Machine, Remote Control Earth Moving Machine, Slip Form Paving Machine (including Gunnert, Zimmerman & similar types), Tower Crane or similar type.

MARICOPA COUNTY ONLY: Backhoe<10 cu yd, Clamshell < 10 cu yd, Concrete Pump (truck mounted with boom only), Dragline <10 cu yd, Grade Checker, Motor Grader (finish-any type power blade), Shovel < 10 cu yd.

GROUP 4: Backhoe 10 cu yd and over, Clamshell 10 cu yd and over, Crane (pneumatic or crawler 100 tons & over), Dragline 10 cu yd and over, Shovel 10 cu yd and over.

All Operators, Oilers, and Motor Crane Drivers on equipment with Booms, except concrete pumping truck booms, including Jibs, shall receive \$0.01 per hour per foot over 80 ft in addition to regular rate of pay

Premium pay for performing hazardous waste removal \$0.50 per hour over base rate.

 * IRON0075-004 10/01/2023

COCONINO, MARICOPA, MOHAVE, YAVAPAI & YUMA COUNTIES

	Rates	Fringes
Ironworker, Rebar.....	\$ 32.00	18.91

- Zone 1: 0 to 50 miles from City Hall in Phoenix or Tucson
- Zone 2: 050 to 100 miles - Add \$4.00
- Zone 3: 100 to 150 miles - Add \$5.00
- Zone 4: 150 miles & over - Add \$6.50

 LAB01184-008 06/01/2023

	Rates	Fringes
Laborers:		
Group 1.....	\$ 24.18	7.59
Group 2.....	\$ 25.82	7.59
Group 3.....	\$ 26.68	7.59
Group 4.....	\$ 27.65	7.59
Group 5.....	\$ 28.75	7.59

LABORERS CLASSIFICATIONS:

GROUP 1: All Counties: Chipper, Rip Rap Stoneman. Pinal County Only: General/Cleanup Laborer. Maricopa County Only: Flagger.

GROUP 2: Asphalt Laborer (Shoveling-excluding Asphalt Raker or Ironer), Bander, Cement Mason Tender, Concrete Mucker, Cutting Torch Operator, Fine Grader, Guinea Chaser, Power Type Concrete Buggy

GROUP 3: Chain Saw, Concrete Small Tools, Concrete Vibrating Machine, Cribber & Shorer (except tunnel), Hydraulic Jacks and similar tools, Operator and Tender of Pneumatic and Electric Tools (not herein separately classified), Pipe Caulker and Back-Up Man-Pipeline, Pipe Wrapper, Pneumatic

Gopher, Pre-Cast Manhole Erector, Rigger and Signal
Man-Pipeline

GROUP 4: Air and Water Washout Nozzleman; Bio-Filter, Pressman, Installer, Operator; Scaffold Laborer; Chuck Tender; Concrete Cutting Torch; Gunite; Hand-Guided Trencher; Jackhammer and/or Pavement Breaker; Scaler (using boson's chair or safety belt); Tamper (mechanical all types).

GROUP 5: AC Dumpman, Asbestos Abatement, Asphalt Raker II, Drill Doctor/Air Tool Repairman, Hazardous Waste Removal, Lead Abatement, Lead Pipeman, Process Piping Installer, Scaler (Driller), Pest Technician/Weed Control, Scissor Lift, Hydro Mobile Scaffold Builder.

PAIN0086-001 04/01/2017

	Rates	Fringes
PAINTER		
PAINTER (Yavapai County only), SAND BLASTER/WATER BLASTER (all Counties).....	\$ 19.58	6.40

ZONE PAY: More than 100 miles from Old Phoenix Courthouse
\$3.50 additional per hour.

* SUAZ2009-001 04/20/2009

	Rates	Fringes
CEMENT MASON.....	\$ 19.28	3.99
ELECTRICIAN.....	\$ 22.84	6.48
IRONWORKER (Rebar)		
Pima County.....	\$ 23.17	14.83
Pinal County.....	\$ 20.27	8.35
LABORER		
Asphalt Raker.....	\$ 15.49 **	3.49
Compaction Tool Operator....	\$ 14.59 **	2.91
Concrete Worker.....	\$ 13.55 **	3.20
Concrete/Asphalt Saw.....	\$ 13.95 **	2.58
Driller-Core, diamond, wagon, air track.....	\$ 16.94 **	3.12
Dumpman Spotter.....	\$ 14.99 **	3.16
Fence Builder.....	\$ 13.28 **	2.99
Flagger		
Coconino, Mohave, Pima, Pinal, Yavapai & Yuma.....	\$ 12.35 **	1.59
Formsetter.....	\$ 16.09 **	3.97
General/Cleanup Laborer		
Coconino, Maricopa, Mohave, Pima, Yavapai & Yuma.....	\$ 14.54 **	3.49
Grade Setter (Pipeline)....	\$ 17.83	5.45
Guard Rail Installer.....	\$ 13.28 **	2.99
Landscape Laborer.....	\$ 11.39 **	
Landscape Sprinkler		
Installer.....	\$ 15.27 **	
Pipelayer.....	\$ 14.81 **	2.96

Powderman, Hydrasonic.....\$ 16.39 **	2.58
OPERATOR: Power Equipment	
Asphalt Laydown Machine.....\$ 21.19	6.05
Backhoe < 1 cu yd	
Coconino, Mohave, Pima,	
Pinal, Yavapai & Yuma.....\$ 17.37	3.85
Backhoe < 10 cu yd	
Coconino, Mohave, Pima,	
Pinal, Yavapai & Yuma.....\$ 18.72	3.59
Clamshell < 10 cu yd	
Coconino, Mohave, Pima,	
Pinal, Yavapai & Yuma.....\$ 18.72	3.59
Concrete Pump (Truck	
Mounted with boom only)	
Coconino, Mohave, Pima,	
Pinal, Yavapai & Yuma.....\$ 19.92	7.10
Crane (under 15 tons).....\$ 21.35	7.36
Dragline (up to 10 cu yd)	
Coconino, Mohave, Pima,	
Pinal, Yavapai & Yuma.....\$ 18.72	3.59
Drilling Machine	
(including Water Wells).....\$ 20.58	5.65
Grade Checker	
Coconino, Mohave, Pima,	
Pinal, Yavapai & Yuma.....\$ 16.04 **	3.68
Hydrographic Seeder.....\$ 15.88 **	7.67
Mass Excavator.....\$ 20.97	4.28
Milling Machine/Rotomill....\$ 21.42	7.45
Motor Grader (Finish-any	
type power blade)	
Coconino, Mohave, Pima,	
Pinal, Yavapai & Yuma.....\$ 21.92	4.66
Motor Grader (Rough)	
Coconino, Mohave, Pima,	
Pinal, Yavapai & Yuma.....\$ 20.07	4.13
Oiler.....\$ 18.15	8.24
Power Sweeper.....\$ 16.76 **	4.44
Roller (all types Asphalt)	
Coconino, Mohave, Pima,	
Pinal, Yavapai & Yuma.....\$ 18.27	3.99
Roller (excluding asphalt)..\$ 15.65 **	3.32
Scraper (pneumatic tired)	
Coconino, Mohave, Pima,	
Pinal, Yavapai & Yuma.....\$ 17.69	3.45
Screed	
Coconino, Mohave, Pima,	
Pinal, Yavapai & Yuma.....\$ 17.54	3.72
Shovel < 10 cu yd	
Coconino, Mohave, Pima,	
Pinal, Yavapai & Yuma.....\$ 18.72	3.59
Skip Loader (all types <3	
cu yd).....\$ 18.28	5.30
Skip Loader (all types 3 <	
6 cu yd)	
Coconino, Mohave, Pima,	
Pinal, Yavapai & Yuma.....\$ 18.64	4.86
Skip Loader (all types 6 <	
10 cu yd).....\$ 20.15	4.52
Tractor (dozer, pusher -	
all)	
Coconino, Mohave, Pima,	
Pinal, Yavapai & Yuma.....\$ 17.26	2.65

PAINTER

Coconino, Maricopa,
Mohave, Pima, Pinal & Yuma..\$ 15.57 ** 3.92

TRUCK DRIVER

2 or 3 Axle Dump or Flatrack.....	\$ 16.27 **	3.30
5 Axle Dump or Flatrack.....	\$ 13.97 **	2.89
6 Axle Dump or Flatrack (< 16 cu yd).....	\$ 17.79	6.42
Belly Dump.....	\$ 14.67 **	
Oil Tanker Bootman.....	\$ 22.03	
Self-Propelled Street Sweeper.....	\$ 13.11 **	5.48
Water Truck 2500 < 3900 gallons.....	\$ 18.14	4.55
Water Truck 3900 gallons and over.....	\$ 15.92 **	3.33
Water Truck under 2500 gallons.....	\$ 15.94 **	4.16

WELDERS - Receive rate prescribed for craft performing
operation to which welding is incidental.

=====
** Workers in this classification may be entitled to a higher
minimum wage under Executive Order 14026 (\$17.20) or 13658
(\$12.90). Please see the Note at the top of the wage
determination for more information. Please also note that the
minimum wage requirements of Executive Order 14026 are not
currently being enforced as to any contract or subcontract to
which the states of Texas, Louisiana, or Mississippi, including
their agencies, are a party.

Note: Executive Order (EO) 13706, Establishing Paid Sick Leave
for Federal Contractors applies to all contracts subject to the
Davis-Bacon Act for which the contract is awarded (and any
solicitation was issued) on or after January 1, 2017. If this
contract is covered by the EO, the contractor must provide
employees with 1 hour of paid sick leave for every 30 hours
they work, up to 56 hours of paid sick leave each year.
Employees must be permitted to use paid sick leave for their
own illness, injury or other health-related needs, including
preventive care; to assist a family member (or person who is
like family to the employee) who is ill, injured, or has other
health-related needs, including preventive care; or for reasons
resulting from, or to assist a family member (or person who is
like family to the employee) who is a victim of, domestic
violence, sexual assault, or stalking. Additional information
on contractor requirements and worker protections under the EO
is available at
<https://www.dol.gov/agencies/whd/government-contracts>.

Unlisted classifications needed for work not included within
the scope of the classifications listed may be added after
award only as provided in the labor standards contract clauses
(29CFR 5.5 (a) (1) (iii)).

The body of each wage determination lists the classification
and wage rates that have been found to be prevailing for the

cited type(s) of construction in the area covered by the wage determination. The classifications are listed in alphabetical order of ""identifiers"" that indicate whether the particular rate is a union rate (current union negotiated rate for local), a survey rate (weighted average rate) or a union average rate (weighted union average rate).

Union Rate Identifiers

A four letter classification abbreviation identifier enclosed in dotted lines beginning with characters other than ""SU"" or ""UAVG"" denotes that the union classification and rate were prevailing for that classification in the survey. Example: PLUM0198-005 07/01/2014. PLUM is an abbreviation identifier of the union which prevailed in the survey for this classification, which in this example would be Plumbers. 0198 indicates the local union number or district council number where applicable, i.e., Plumbers Local 0198. The next number, 005 in the example, is an internal number used in processing the wage determination. 07/01/2014 is the effective date of the most current negotiated rate, which in this example is July 1, 2014.

Union prevailing wage rates are updated to reflect all rate changes in the collective bargaining agreement (CBA) governing this classification and rate.

Survey Rate Identifiers

Classifications listed under the ""SU"" identifier indicate that no one rate prevailed for this classification in the survey and the published rate is derived by computing a weighted average rate based on all the rates reported in the survey for that classification. As this weighted average rate includes all rates reported in the survey, it may include both union and non-union rates. Example: SULA2012-007 5/13/2014. SU indicates the rates are survey rates based on a weighted average calculation of rates and are not majority rates. LA indicates the State of Louisiana. 2012 is the year of survey on which these classifications and rates are based. The next number, 007 in the example, is an internal number used in producing the wage determination. 5/13/2014 indicates the survey completion date for the classifications and rates under that identifier.

Survey wage rates are not updated and remain in effect until a new survey is conducted.

Union Average Rate Identifiers

Classification(s) listed under the UAVG identifier indicate that no single majority rate prevailed for those classifications; however, 100% of the data reported for the classifications was union data. EXAMPLE: UAVG-OH-0010 08/29/2014. UAVG indicates that the rate is a weighted union average rate. OH indicates the state. The next number, 0010 in the example, is an internal number used in producing the wage determination. 08/29/2014 indicates the survey completion date for the classifications and rates under that identifier.

A UAVG rate will be updated once a year, usually in January of each year, to reflect a weighted average of the current negotiated/CBA rate of the union locals from which the rate is based.

WAGE DETERMINATION APPEALS PROCESS

1.) Has there been an initial decision in the matter? This can be:

- * an existing published wage determination
- * a survey underlying a wage determination
- * a Wage and Hour Division letter setting forth a position on a wage determination matter
- * a conformance (additional classification and rate) ruling

On survey related matters, initial contact, including requests for summaries of surveys, should be with the Wage and Hour National Office because National Office has responsibility for the Davis-Bacon survey program. If the response from this initial contact is not satisfactory, then the process described in 2.) and 3.) should be followed.

With regard to any other matter not yet ripe for the formal process described here, initial contact should be with the Branch of Construction Wage Determinations. Write to:

Branch of Construction Wage Determinations
Wage and Hour Division
U.S. Department of Labor
200 Constitution Avenue, N.W.
Washington, DC 20210

2.) If the answer to the question in 1.) is yes, then an interested party (those affected by the action) can request review and reconsideration from the Wage and Hour Administrator (See 29 CFR Part 1.8 and 29 CFR Part 7). Write to:

Wage and Hour Administrator
U.S. Department of Labor
200 Constitution Avenue, N.W.
Washington, DC 20210

The request should be accompanied by a full statement of the interested party's position and by any information (wage payment data, project description, area practice material, etc.) that the requestor considers relevant to the issue.

3.) If the decision of the Administrator is not favorable, an interested party may appeal directly to the Administrative Review Board (formerly the Wage Appeals Board). Write to:

Administrative Review Board
U.S. Department of Labor
200 Constitution Avenue, N.W.
Washington, DC 20210

4.) All decisions by the Administrative Review Board are final.

=====
END OF GENERAL DECISION"

Superseded General Decision Number: AZ20230009

State: Arizona

Construction Type: Highway

Counties: Apache, Cochise, Gila, Graham, Greenlee, La Paz, Navajo and Santa Cruz Counties in Arizona.

HIGHWAY CONSTRUCTION PROJECTS

Note: Contracts subject to the Davis-Bacon Act are generally required to pay at least the applicable minimum wage rate required under Executive Order 14026 or Executive Order 13658. Please note that these Executive Orders apply to covered contracts entered into by the federal government that are subject to the Davis-Bacon Act itself, but do not apply to contracts subject only to the Davis-Bacon Related Acts, including those set forth at 29 CFR 5.1(a)(1).

If the contract is entered into on or after January 30, 2022, or the contract is renewed or extended (e.g., an option is exercised) on or after January 30, 2022:	<ul style="list-style-type: none">. Executive Order 14026 generally applies to the contract.. The contractor must pay all covered workers at least \$17.20 per hour (or the applicable wage rate listed on this wage determination, if it is higher) for all hours spent performing on the contract in 2024.
If the contract was awarded on or between January 1, 2015 and January 29, 2022, and the contract is not renewed or extended on or after January 30, 2022:	<ul style="list-style-type: none">. Executive Order 13658 generally applies to the contract.. The contractor must pay all covered workers at least \$12.90 per hour (or the applicable wage rate listed on this wage determination, if it is higher) for all hours spent performing on that contract in 2024.

The applicable Executive Order minimum wage rate will be adjusted annually. If this contract is covered by one of the Executive Orders and a classification considered necessary for performance of work on the contract does not appear on this wage determination, the contractor must still submit a conformance request.

Additional information on contractor requirements and worker protections under the Executive Orders is available at <http://www.dol.gov/whd/govcontracts>.

CARP0408-007 07/01/2023

APACHE, COCHISE & SANTA CRUZ COUNTIES

	Rates	Fringes
CARPENTER (Including Cement Form Work).....	\$ 34.50	14.17

ENGI0428-004 06/01/2023

	Rates	Fringes
POWER EQUIPMENT OPERATOR Oiler Driver.....	\$ 34.96	13.52

* IRON0075-006 10/01/2023

Apache, Cochise, Gila, Graham, Greenlee, La Paz, Navajo Counties

	Rates	Fringes
Ironworker, Rebar.....	\$ 32.00	18.91
Zone 1: 0 to 50 miles from City Hall in Phoenix or Tucson		
Zone 2: 050 to 100 miles - Add \$4.00		
Zone 3: 100 to 150 miles - Add \$5.00		
Zone 4: 150 miles & over - Add \$6.50		

* SUAZ2009-002 04/23/2009

	Rates	Fringes
CARPENTER Gila, Graham, Greenlee, La Paz & Navajo.....	\$ 21.71	3.82
CEMENT MASON.....	\$ 17.74	3.59
ELECTRICIAN.....	\$ 24.43	5.38
IRONWORKER, Rebar Santa Cruz county.....	\$ 21.75	13.59
LABORER		
Asphalt Raker.....	\$ 14.97 **	5.88
Concrete Worker.....	\$ 13.38 **	4.50
Fence Builder.....	\$ 12.20 **	3.84
Flagger.....	\$ 12.31 **	3.96
General/Cleanup.....	\$ 12.78 **	2.50
Guard Rail Installer.....	\$ 12.20 **	3.84
Landscape Laborer.....	\$ 11.02 **	
Water Blaster.....	\$ 14.90 **	2.90
OPERATOR: Power Equipment		
Backhoe < 1 cu yd.....	\$ 17.76	3.89
Compactor Self Propelled (with blade-grade operation..)	\$ 22.53	6.57
Compactor Small Self Propelled (with blade- backfill, ditch operation)..	\$ 22.29	6.31
Concrete Pump.....	\$ 20.31	6.48

Crane (under 15 tons).....	\$ 22.98	4.26
Drilling Machine (including wells).....	\$ 21.79	4.10
Grade Checker.....	\$ 23.41	6.54
Hydrographic Seeder.....	\$ 19.73	5.40
Mass Excavator.....	\$ 23.33	6.98
Milling Machine/Rotomill....	\$ 21.87	6.84
Power Sweeper.....	\$ 19.33	4.85
Roller (all types asphalt)..	\$ 17.46	5.58
Roller (excluding asphalt)..	\$ 19.23	5.09
Scraper (pneumatic tire)....	\$ 22.41	6.90
Screed.....	\$ 20.90	6.72
Skip Loader (all types 3 < 6 cu yd).....	\$ 20.91	7.35
Skip Loader (all types 6 < 10 cu yd).....	\$ 22.24	6.83
Skip Loader < 3 cu yd.....	\$ 17.97	6.60
Tractor (dozer, pusher- all).....	\$ 22.53	6.47
Tractor (wheel type).....	\$ 24.62	7.57
 PAINTER.....	\$ 13.94 **	2.56
 TRUCK DRIVER		
2 or 3 axle Dump or Flatrack.....	\$ 16.17 **	4.24
Oil Tanker Bootman.....	\$ 21.94	
Pickup.....	\$ 12.88 **	1.73
Water Truck < 2500 gal.....	\$ 19.59	5.90
Water Truck > 3900 gal.....	\$ 18.70	4.79
Water Truck 2500 < 3900 gal.....	\$ 17.13 **	

WELDERS - Receive rate prescribed for craft performing operation to which welding is incidental.

=====

** Workers in this classification may be entitled to a higher minimum wage under Executive Order 14026 (\$17.20) or 13658 (\$12.90). Please see the Note at the top of the wage determination for more information. Please also note that the minimum wage requirements of Executive Order 14026 are not currently being enforced as to any contract or subcontract to which the states of Texas, Louisiana, or Mississippi, including their agencies, are a party.

Note: Executive Order (EO) 13706, Establishing Paid Sick Leave for Federal Contractors applies to all contracts subject to the Davis-Bacon Act for which the contract is awarded (and any solicitation was issued) on or after January 1, 2017. If this contract is covered by the EO, the contractor must provide employees with 1 hour of paid sick leave for every 30 hours they work, up to 56 hours of paid sick leave each year. Employees must be permitted to use paid sick leave for their own illness, injury or other health-related needs, including preventive care; to assist a family member (or person who is like family to the employee) who is ill, injured, or has other health-related needs, including preventive care; or for reasons resulting from, or to assist a family member (or person who is like family to the employee) who is a victim of, domestic violence, sexual assault, or stalking. Additional information on contractor requirements and worker protections under the EO is available at

<https://www.dol.gov/agencies/whd/government-contracts>.

Unlisted classifications needed for work not included within the scope of the classifications listed may be added after award only as provided in the labor standards contract clauses (29CFR 5.5 (a) (1) (iii)).

The body of each wage determination lists the classification and wage rates that have been found to be prevailing for the cited type(s) of construction in the area covered by the wage determination. The classifications are listed in alphabetical order of ""identifiers"" that indicate whether the particular rate is a union rate (current union negotiated rate for local), a survey rate (weighted average rate) or a union average rate (weighted union average rate).

Union Rate Identifiers

A four letter classification abbreviation identifier enclosed in dotted lines beginning with characters other than ""SU"" or ""UAVG"" denotes that the union classification and rate were prevailing for that classification in the survey. Example: PLUM0198-005 07/01/2014. PLUM is an abbreviation identifier of the union which prevailed in the survey for this classification, which in this example would be Plumbers. 0198 indicates the local union number or district council number where applicable, i.e., Plumbers Local 0198. The next number, 005 in the example, is an internal number used in processing the wage determination. 07/01/2014 is the effective date of the most current negotiated rate, which in this example is July 1, 2014.

Union prevailing wage rates are updated to reflect all rate changes in the collective bargaining agreement (CBA) governing this classification and rate.

Survey Rate Identifiers

Classifications listed under the ""SU"" identifier indicate that no one rate prevailed for this classification in the survey and the published rate is derived by computing a weighted average rate based on all the rates reported in the survey for that classification. As this weighted average rate includes all rates reported in the survey, it may include both union and non-union rates. Example: SULA2012-007 5/13/2014. SU indicates the rates are survey rates based on a weighted average calculation of rates and are not majority rates. LA indicates the State of Louisiana. 2012 is the year of survey on which these classifications and rates are based. The next number, 007 in the example, is an internal number used in producing the wage determination. 5/13/2014 indicates the survey completion date for the classifications and rates under that identifier.

Survey wage rates are not updated and remain in effect until a new survey is conducted.

Union Average Rate Identifiers

Classification(s) listed under the UAVG identifier indicate that no single majority rate prevailed for those classifications; however, 100% of the data reported for the

classifications was union data. EXAMPLE: UAVG-OH-0010
08/29/2014. UAVG indicates that the rate is a weighted union
average rate. OH indicates the state. The next number, 0010 in
the example, is an internal number used in producing the wage
determination. 08/29/2014 indicates the survey completion date
for the classifications and rates under that identifier.

A UAVG rate will be updated once a year, usually in January of
each year, to reflect a weighted average of the current
negotiated/CBA rate of the union locals from which the rate is
based.

WAGE DETERMINATION APPEALS PROCESS

1.) Has there been an initial decision in the matter? This can
be:

- * an existing published wage determination
- * a survey underlying a wage determination
- * a Wage and Hour Division letter setting forth a position on
a wage determination matter
- * a conformance (additional classification and rate) ruling

On survey related matters, initial contact, including requests
for summaries of surveys, should be with the Wage and Hour
National Office because National Office has responsibility for
the Davis-Bacon survey program. If the response from this
initial contact is not satisfactory, then the process described
in 2.) and 3.) should be followed.

With regard to any other matter not yet ripe for the formal
process described here, initial contact should be with the
Branch of Construction Wage Determinations. Write to:

Branch of Construction Wage Determinations
Wage and Hour Division
U.S. Department of Labor
200 Constitution Avenue, N.W.
Washington, DC 20210

2.) If the answer to the question in 1.) is yes, then an
interested party (those affected by the action) can request
review and reconsideration from the Wage and Hour Administrator
(See 29 CFR Part 1.8 and 29 CFR Part 7). Write to:

Wage and Hour Administrator
U.S. Department of Labor
200 Constitution Avenue, N.W.
Washington, DC 20210

The request should be accompanied by a full statement of the
interested party's position and by any information (wage
payment data, project description, area practice material,
etc.) that the requestor considers relevant to the issue.

3.) If the decision of the Administrator is not favorable, an
interested party may appeal directly to the Administrative
Review Board (formerly the Wage Appeals Board). Write to:

Administrative Review Board
U.S. Department of Labor

200 Constitution Avenue, N.W.
Washington, DC 20210

4.) All decisions by the Administrative Review Board are final.

=====

END OF GENERAL DECISION"

Attachment 4 to Exhibit 9, Part A

STANDARD FEDERAL EQUAL EMPLOYMENT OPPORTUNITY CONSTRUCTION CONTRACT SPECIFICATIONS (EXECUTIVE ORDER 11246) (41 CFR 60-4.3)

1. As used in these specifications:
 - a. “Covered area” means the geographical area described in the solicitation from which this contract resulted;
 - b. “Director” means Director, Office of Federal Contract Compliance Programs, United States Department of Labor, or any person to whom the Director delegates authority;
 - c. “Employer identification number” means the Federal Social Security number used on the Employer’s Quarterly Federal Tax Return, U.S. Treasury Department Form 941.
 - d. “Minority” includes:
 - (i) Black (all persons having origins in any of the Black African racial groups not of Hispanic origin);
 - (ii) Hispanic (all persons of Mexican, Puerto Rican, Cuban, Central or South American or other Spanish Culture or origin, regardless of race);
 - (iii) Asian and Pacific Islander (all persons having origins in any of the original peoples of the Far East, Southeast Asia, the Indian Subcontinent, or the Pacific Islands); and
 - (iv) American Indian or Alaskan Native (all persons having origins in any of the original peoples of North America and maintaining identifiable tribal affiliations through membership and participation or community identification).
 - e. “Contractor” includes the Developer and each Contractor.
2. Reserved.
3. If the Contractor is participating (pursuant to 41 CFR 60–4.5) in a Hometown Plan approved by the U.S. Department of Labor in the covered area either individually or through an association, its affirmative action obligations on all work in the Plan area (including goals and timetables) shall be in accordance with that Plan for those trades which have unions participating in the Plan. Contractors must be able to demonstrate their participation in and compliance with the provisions of any such Hometown Plan. Each Contractor or Subcontractor participating in an approved Plan is individually required to comply with its obligations under the EEO clause, and to make a good faith effort to achieve each goal under the Plan in each trade in which it has employees. The overall good faith performance by other Contractors or Subcontractors toward a goal in

an approved Plan does not excuse any covered Contractor's or Subcontractor's failure to take good faith efforts to achieve the Plan goals and timetables.

4. The Contractor shall implement the specific affirmative action standards provided in paragraphs 7a through p of these specifications.

5. Neither the provisions of any collective bargaining agreement, nor the failure by a union with whom the Contractor has a collective bargaining agreement, to refer either minorities or women shall excuse the Contractor's obligations under these specifications, Executive Order 11246, or the regulations promulgated pursuant thereto.

6. [Reserved.]

7. The Contractor shall take specific affirmative actions to ensure equal employment opportunity. The evaluation of the Contractor's compliance with these specifications shall be based upon its effort to achieve maximum results from its actions. The Contractor shall document these efforts fully, and shall implement affirmative action steps at least as extensive as the following:

a. Ensure and maintain a working environment free of harassment, intimidation, and coercion at all sites, and in all facilities at which the Contractor's employees are assigned to work. The Contractor, where possible, will assign two or more women to each construction project. The Contractor shall specifically ensure that all foremen, superintendents, and other on-site supervisory personnel are aware of and carry out the Contractor's obligation to maintain such a working environment, with specific attention to minority or female individuals working at such sites or in such facilities.

b. Establish and maintain a current list of minority and female recruitment sources, provide written notification to minorities and female recruitment sources and to community organizations when the Contractor or its unions have employment opportunities available, and maintain a record of the organizations' responses.

c. Maintain a current file of the names, addresses and telephone numbers of each minority and female off-the-street applicant and minority or female referral from a union, a recruitment source or community organization and of what action was taken with respect to each such individual. If such individual was sent to the union hiring hall for referral and was not referred back to the Contractor by the union or, if referred, not employed by the Contractor, this shall be documented in the file with the reason therefor, along with whatever additional actions the Contractor may have taken.

d. Provide immediate written notification to the Director when the union or unions with which the Contractor has a collective bargaining agreement has not referred to the Contractor a minority person or woman sent by the Contractor, or when the Contractor has other information that the union referral process has impeded the Contractor's efforts to meet its obligations.

e. Develop on-the-job training opportunities and/or participate in training programs for the area which expressly include minority and women, including upgrading programs and apprenticeship and trainee programs relevant to the Contractor's employment needs, especially those programs funded or approved by the Department of Labor. The Contractor shall provide notice of these programs to the sources compiled under 7b above.

f. Disseminate the Contractor's EEO policy by providing notice of the policy to unions and training programs and requesting their cooperation in assisting the Contractor in meeting its EEO obligations; by including it in any policy manual and collective bargaining agreement; by publicizing it in the company newspaper, annual report, etc.; by specific review of the policy with all management personnel and with all minority and female employees at least once a year and by posting the company EEO policy on bulletin boards accessible to all employees at each location where construction work is performed.

g. Review, at least annually, the company's EEO policy and affirmative action obligations under these specifications with all employees having any responsibility for hiring, assignment, layoff, termination or other employment decisions including specific review of these items with onsite supervisory personnel such as Superintendents, General Foremen, etc., prior to the initiation of construction work at any job site. A written record shall be made and maintained identifying the time and place of these meetings, persons attending, subject matter discussed, and disposition of the subject matter.

h. Disseminate the Contractor's EEO policy externally by including it in any advertising in the news media, specifically including minority and female news media, and providing written notification to and discussing the Contractor's EEO policy with other Contractors and Subcontractors with whom the Contractor does or anticipates doing business.

i. Direct its recruitment efforts, both oral and written, to minority, female and community organizations, to schools with minority and female students and to minority and female recruitment and training organizations serving the Contractor's recruitment area and employment needs. Not later than one month prior to the date for the acceptance of applications for apprenticeship or other training by any recruitment source, the Contractor shall send written notification to organizations such as the above, describing the openings, screening procedures, and tests to be used in the selection process.

j. Encourage present minority and female employees to recruit other minority persons and women and, where reasonable, provide after school, summer and vacation employment to minority and female youth both on the site and in other areas of a Contractor's work force.

k. Validate all tests and other selection requirements where there is an obligation to do so under 41 CFR Part 60-3.

l. Conduct, at least annually, an inventory and evaluation at least of all minority and female personnel for promotional opportunities and encourage these employees to seek or to prepare for, through appropriate training, etc. such opportunities.

m. Ensure that seniority practices, job classifications, work assignments and other personnel practices, do not have a discriminatory effect by continually monitoring all personnel and employment related activities to ensure that the EEO policy and the Contractor's obligations under these specifications are being carried out.

n. Ensure that all facilities and company activities are nonsegregated except that separate or single-user toilet and necessary changing facilities shall be provided to assure privacy between the sexes.

o. Document and maintain a record of all solicitations of offers for subcontracts from minority and female construction contractors and suppliers, including circulation of solicitations to minority and female contractor associations and other business associations.

p. Conduct a review, at least annually of all supervisors' adherence to and performance under the Contractor's EEO policies and affirmative action obligations.

8. [Contractors are encouraged to participate in voluntary associations which assist in fulfilling one or more of their affirmative action obligations (7a through p). The efforts of a contractor association, joint contractor-union, contractor-community, or other similar group of which the contractor is a member and participant, may be asserted as fulfilling any one or more of its obligations under 7a through p of these Specifications provided that the contractor actively participates in the group, makes every effort to assure that the group has a positive impact on the employment of minorities and women in the industry, ensures that the concrete benefits of the program are reflected in the Contractor's minority and female workforce participation, makes a good faith effort to meet its individual goals and timetables, and can provide access to documentation which demonstrates the effectiveness of actions taken on behalf of the Contractor. The obligation to comply, however, is the Contractor's and failure of such a group to fulfill an obligation shall not be a defense for the Contractor's noncompliance.]

9. A single goal for minorities and a separate single goal for women have been established. The Contractor, however, is required to provide equal employment opportunity and to take affirmative action for all minority groups, both male and female, and all women, both minority and non-minority. Consequently, the Contractor may be in violation of the Executive Order if a particular group is employed in a substantially disparate manner (for example, even though the Contractor has achieved its goals for women generally, the Contractor may be in violation of the Executive Order if a specific minority group of women is underutilized).

10. The Contractor shall not use or affirmative action standards to discriminate against any person because of race, color, religion, sex, or national origin.

11. The Contractor shall not enter into any Contract or Subcontract with any person or firm debarred from Government contracts pursuant to Executive Order 11246.

12. The Contractor shall carry out such sanctions and penalties for violation of these specifications and of the Equal Opportunity Clause, including suspension, termination and cancellation of existing subcontracts as may be imposed or ordered pursuant to Executive Order 11246, as amended, and its implementing regulations, by the Office of Federal Contract Compliance Programs. Any Contractor who fails to carry out such sanctions and penalties shall be in violation of these specifications and Executive Order 11246, as amended.

13. [The Contractor, in fulfilling its obligations under these specifications, shall implement specific affirmative action steps, at least as extensive as those standards prescribed in paragraph 7 of these specifications, so as to achieve maximum results from its efforts to ensure equal employment opportunity. If the Contractor fails to comply with the requirements of the Executive Order, the implementing regulations, or these specifications, the Director shall proceed in accordance with 41 CFR 60–4.8.]

14. [The Contractor shall designate a responsible official to monitor all employment related activity to ensure that the company EEO policy is being carried out, to submit reports relating to the provisions hereof as may be required by the Government and to keep records. Records shall at least include for each employee the name, address, telephone numbers, construction trade, union affiliation if any, employee identification number when assigned, social security number, race, sex, status (e.g., mechanic, apprentice trainee, helper, or laborer), dates of changes in status, hours worked per week in the indicated trade, rate of pay, and locations at which the work was performed. Records shall be maintained in an easily understandable and retrievable form; however, to the degree that existing records satisfy this requirement, contractors shall not be required to maintain separate records.]

15. [Nothing herein provided shall be construed as a limitation upon the application of other laws which establish different standards of compliance or upon the application of requirements for the hiring of local or other area residents (e.g., those under the Public Works Employment Act of 1977 and the Community Development Block Grant Program).]

Attachment 5 to Exhibit 9, Part A

CERTIFICATION REGARDING USE OF CONTRACT FUNDS FOR LOBBYING

By signing and submitting its proposal or bid, and by executing the Agreement, the Developer and Contractors (at all tiers) shall be deemed to have signed and delivered the following:

1. The Developer and Contractor certifies, to the best of its knowledge and belief, that:

a. No federal appropriated funds have been paid or will be paid, by or on behalf of the undersigned, to any person for influencing or attempting to influence an officer or employee of any Federal agency, a Member of Congress, an officer or employee of Congress, or an employee of a Member of Congress in connection with the awarding of any federal contract, the making of any federal grant, the making of any federal loan, the entering into of any cooperative agreement, and the extension, continuation, renewal, amendment, or modification of any federal contract, grant, loan, or cooperative agreement.

b. If any funds other than federal appropriated funds have been paid or will be paid to any person for influencing or attempting to influence an officer or employee of any federal agency, a Member of Congress, an officer or employee of Congress, or an employee of a Member of Congress in connection with this federal contract, grant, loan, or cooperative agreement, the undersigned shall complete and submit Standard Form-LLL, "Disclosure Form to Report Lobbying," in accordance with its instructions, and shall include a copy of said form in its proposal or bid, or submit it with the executed Agreement or Contract.

2. This certification is a material representation of fact upon which reliance was placed when this transaction was made or entered into. Submission of this certification is a prerequisite for making or entering into this transaction imposed by 31 U.S.C. § 1352. Any person who fails to file the required certification shall be subject to a civil penalty of not less than \$10,000 and not more than \$100,000 for each such failure.

3. Developer/Contractor shall require that the language of this certification be included in all lower tier subcontracts, which exceed \$100,000 and that all such recipients shall certify and disclose accordingly.

4. The undersigned certifies or affirms the truthfulness and accuracy of each statement of its certification and disclosure, if any. In addition, the undersigned understands and agrees that the provisions of 31 U.S.C. § 3801 et seq., apply to this certification and disclosure, if any.

[Note: Pursuant to 31 U.S.C. § 1352(c)(1)-(2)(A), any person who makes a prohibited expenditure or fails to file or amend a required certification or disclosure form shall be

subject to a civil penalty of not less than \$10,000 and not more than \$100,000 for each expenditure or failure.]

NOTE: DEVELOPER AND EACH CONTRACTOR IS REQUIRED, PURSUANT TO FEDERAL LAW, TO INCLUDE THE ABOVE LANGUAGE IN CONTRACTS OVER \$100,000 AND TO OBTAIN THIS LOBBYING CERTIFICATE FROM EACH CONTRACTOR BEING PAID \$100,000 OR MORE.

Attachment 6 to Exhibit 9, Part A

SUSPENSION AND DEBARMENT CERTIFICATION

By signing and submitting its proposal or bid, and by executing the Agreement, the Developer and Contractors (at all tiers) shall be deemed to have signed and delivered the following certification:

1. The undersigned certifies to the best of its knowledge and belief, that it and its principals:

a. are not presently debarred, suspended, proposed for debarment, declared ineligible, or voluntarily excluded from covered transactions by any federal department or agency;

b. have not within a three-year period preceding this certification been convicted of or had a civil judgment rendered against them for commission of fraud or a criminal offense in connection with obtaining, attempting to obtain, or performing a public (federal, state or local) transaction or contract under a public transaction; violation of federal or state antitrust statutes or commission of embezzlement, theft, forgery, bribery, falsification or destruction of records, making false statements, or receiving stolen property;

c. are not presently indicted for or otherwise criminally or civilly charged by a governmental entity (federal, state or local) with commission of any of the offenses enumerated in paragraph 1(b) of this certification;

d. have not within a three-year period preceding this application/proposal had one or more public transactions (federal, state or local) terminated for cause or default;

e. are not a corporation that has been convicted of a felony violation under any federal law within the two-year period preceding this proposal (USDOT Order 4200.6 implementing appropriations act requirements); and

f. are not a corporation with any unpaid federal tax liability that has been assessed, for which all judicial and administrative remedies have been exhausted, or have lapsed, and that is not being paid in a timely manner pursuant to an agreement with the authority responsible for collecting the tax liability (USDOT Order 4200.6 implementing appropriations act requirements).

2. Where the Developer or a Contractor is unable to certify to any of the statements in this certification, the Developer or Contractor shall submit a certificate (a) that it is unable to provide the certification and (b) explaining the reasons for such inability.

Attachment 7 to Exhibit 9, Part A

COMPLIANCE WITH BUY AMERICA AND BUILD AMERICA, BUY AMERICA REQUIREMENTS

Developer shall comply with the requirements of 23 CFR 635.313, as amended by the Build America, Buy America Act (under the Infrastructure Investment and Jobs Act/Bipartisan Infrastructure Law, Pub. L. 117-58, Nov. 15, 2021), and the federal regulations under 23 CFR 635.410, 2 CFR 200.322 and 2 CFR 184.

23 CFR 635.410 permits federal financial assistance in the Project Agreement only if (a) all iron and steel used in the Project are produced in the United States (i.e., all manufacturing processes, from the initial melting stage through the application of coatings, occur in the United States); (b) all manufactured products²⁷²⁸ used in the Project are produced in the United States (i.e., the manufactured product was manufactured in the United States; and the cost of the components of the manufactured product that are mined, produced, or manufactured in the United States is greater than 55 percent of the total cost of all components of the manufactured product²⁸²⁹, unless another standard for determining the minimum amount of domestic content of the manufactured product has been established under applicable law or regulation); and (c) all construction materials²⁹³⁰ are manufactured in the United States (i.e., all manufacturing processes for the construction material occurred in the United States and satisfy the material-specific requirements set forth in 2 CFR 184.6); provided, however, that the following exceptions shall apply:

- (i) iron and steel where all manufacturing processes did not occur in the United States may be used so long as the cumulative cost of such steel and iron materials as they are delivered to the Project does not exceed 0.1% of the total contract amount, or \$2,500, whichever is greater;
- (ii) construction materials and manufactured products³⁰³¹ not meeting the requirements set forth in subsections (b) and (c) above may be used so long as no more than the lesser of (A) \$1,000,000, or (B) 5% of total applicable costs for the Project (defined as the total cost of iron and steel, manufactured products, and construction materials used in the Project, whether or not within the scope of an existing waiver); and

²⁷²⁸ “Manufactured products” is as defined in 2 CFR 184.3

²⁸²⁹ To be calculated in accordance with 2 CFR 184.5.

²⁹³⁰ “Construction Materials” is defined in 2 CFR 184.3 (as affected by Section 70917(c)(1) of the Infrastructure Investment and Jobs Act).

³⁰³¹ A nationwide Buy America waiver that supersedes Build America, Buy America requirements is currently in effect for manufactured products. Manufactured products that are not predominantly steel or iron fall under this waiver and are allowable for use without regard to country of origin. “Predominantly steel or iron” is defined as greater than or equal to 50 percent of the total cost of the manufactured product.

- (iii) no domestic preference requirements under the statutes and regulations covered by this certification shall be applicable where the total amount of federal financial assistance applied to the project, through awards or subawards, is below \$500,000.

The Buy America preference only applies to articles, materials, and supplies that are consumed in, incorporated into, or affixed to an infrastructure project. As such, it does not apply to tools, equipment, and supplies, such as temporary scaffolding, brought to the construction site and removed at or before the completion of the infrastructure project. Nor does a Buy America preference apply to equipment and furnishings, such as movable chairs, desks, and portable computer equipment, that are used at or within the finished infrastructure project, but are not an integral part of the structure or permanently affixed to the infrastructure project.

Concurrently with execution, the Developer has completed and submitted, or shall complete and submit, to ADOT a Buy America Certificate and a Build America, Buy America Certificate, each in the format set forth in this Exhibit 9. After submittal, the Developer is bound by its certifications.

A false certification is a criminal act in violation of 18 U.S.C. § 1001. Should the Developer be investigated, the Developer has the burden of proof to establish that it is in compliance.

At the Developer's request, ADOT may, but is not obligated to, seek a waiver of Buy America requirements if grounds for the waiver exist, pursuant to 23 CFR 635.410(c), as amended by the Build America, Buy America Act (under the Infrastructure Investment and Jobs Act/Bipartisan Infrastructure Law, Pub. L. 117-58, Nov. 15, 2021) and 2 CFR 184.7. However, the Developer certifies that it will comply with the applicable Buy America requirements if a waiver of those requirements is not available or not pursued by ADOT.

Capitalized terms used, but not otherwise defined in this Attachment 7 of Exhibit 9, Part A (Federal Requirements) have the meanings ascribed in PA Exhibit 1 (Acronyms and Definitions).

BUY AMERICA CERTIFICATE

Certificate of Compliance

The Developer hereby certifies that it is in compliance with the requirements of 23 U.S.C. § 313 as amended by the Build America, Buy America Act (under the Infrastructure Investment and Jobs Act/Bipartisan Infrastructure Law, Pub. L. 117-58, Nov. 15, 2021), and the Federal regulations under 23 CFR 635.410, 2 CFR 200.322(c), and 2 CFR 184 for the Project.

The Developer further certifies that as required, the Developer will maintain all records and documents pertinent to the Buy America requirement, for not less than three years from the Services Commencement Date. These files will be available for inspection and verification by ADOT and/or FHWA.

We further certify that the cumulative cost of foreign iron and steel as described in the Buy America requirements for each Project Site will not exceed one-tenth of one percent (0.1%) of the total contract price or \$2,500.00, whichever is greater.

Date: _____

Signature: _____

Developer's Name: _____

Title: _____

Subscribed and sworn to before me this _ day of _____, _____

My Commission Expires: _____

Notary Public/Justice of the Peace

Or [The Certificate for Noncompliance is located in the following page.]

Certificate for Noncompliance

With respect to the following project:

Arizona NEVI Deployment Program: Phase 1 – Interstates – NEVI Zone [**Insert
Number**]

The Developer hereby certifies that it cannot comply with the requirements of 23 U.S.C. § 313, as amended by the Build America, Buy America Act (under the Infrastructure Investment and Jobs Act/Bipartisan Infrastructure Law, Pub. L. 117-58, Nov. 15, 2021), and the applicable regulations under 23 CFR 635.410, 2 CFR 200.322(c), and 2 CFR 184, but may qualify for a waiver to these requirement(s) pursuant to the foregoing statutes and regulations.

The Developer acknowledges, agrees, and further certifies that if the foregoing waiver of requirements is not available or not pursued by ADOT, then the Developer shall comply with, and cause all Contractors of any tier to comply with, the applicable Buy America requirements within the foregoing statutes and regulations and submit, and cause to be submitted, promptly following Notice from ADOT to the Developer of such unavailability or intent not to pursue such waiver, a Certificate of Compliance in form and substance under this Attachment 7 of Exhibit 9, Part A (Federal Requirements).

Date: _____
Signature: _____
Developer's Name: _____
Title: _____

Subscribed and sworn to before me this __ day of _____, _____

My Commission Expires: _____

Notary Public/Justice of the Peace

BUILD AMERICA, BUY AMERICA
CERTIFICATE OF COMPLIANCE FOR CONSTRUCTION MATERIALS

The Developer certifies that it is in compliance with the Build America, Buy America (“BABA”) requirements of the Infrastructure Investment and Jobs Act (“IIJA”), as set forth under Pub. L. No. 117-58, §§ 70901-52, and that all construction materials as defined under BABA furnished for the Project will have been produced in the United States of America. The Developer further certifies that as required, the Developer will maintain all records and documents pertinent to the Buy America requirement, at the address given below, for not less than three years from the Services Commencement Date [for each applicable Project Site]. These files will be available for inspection and verification by ADOT and/or FHWA.

Date: _____

Signature: _____

Developer’s Name: _____

Title: _____

Subscribed and sworn to before me this _ day of _____, _____

My Commission Expires: _____

Notary Public/Justice of the Peace

Attachment 8 to Exhibit 9, Part A

FORM 1391

FEDERAL-AID HIGHWAY CONSTRUCTION CONTRACTORS ANNUAL EEO REPORT

1. MARK APPROPRIATE BLOCK <input type="checkbox"/> Contractor <input type="checkbox"/> Subcontractor			2. COMPANY NAME, CITY, STATE:				3. PROJECT NUMBER:				4. DOLLAR AMOUNT OF CONTRACT:				5. PROJECT LOCATION: (County and State)								
This collection of information is required by law and regulation 23 U.S.C. 140a and 23 CFR Part 230. The OMB control number for this collection is 2125-0019 expiring in August, 2019.																							
6. WORKFORCE ON FEDERAL-AID AND CONSTRUCTION SITE(S) DURING LAST FULL PAY PERIOD ENDING IN JULY 20 (INSERT YEAR)																							
TABLE A																TABLE B							
JOB CATEGORIES		TOTAL EMPLOYED		TOTAL RACIAL/ ETHNIC MINORITY		BLACK or AFRICAN AMERICAN		HISPANIC OR LATINO		AMERICAN INDIAN OR ALASKA NATIVE		ASIAN		NATIVE HAWAIIAN OR OTHER PACIFIC ISLANDER		TWO OR MORE RACES		WHITE		APPRENTICES		ON THE JOB TRAINEES	
	M	F	M	F	M	F	M	F	M	F	M	F	M	F	M	F	M	F	M	F	M	F	
OFFICIALS	0	0	0	0																			
SUPERVISORS	0	0	0	0																			
FOREMEN/WOMEN	0	0	0	0																			
CLERICAL	0	0	0	0																			
EQUIPMENT OPERATORS	0	0	0	0																			
MECHANICS	0	0	0	0																			
TRUCK DRIVERS	0	0	0	0																			
IRONWORKERS	0	0	0	0																			
CARPENTERS	0	0	0	0																			
CEMENT MASONS	0	0	0	0																			
ELECTRICIANS	0	0	0	0																			
PIPEFITTER/PLUMBERS	0	0	0	0																			
PAINTERS	0	0	0	0																			
LABORERS-SEMI SKILLED	0	0	0	0																			
LABORERS-UNSKILLED	0	0	0	0																			
TOTAL	0	0	0	0	0	0	0	0	0	0	0	0	0	0	0	0	0	0	0	0	0	0	
TABLE C (Table B data by racial status)																							
APPRENTICES	0	0	0	0																			
OJT TRAINEES	0	0	0	0																			
8. PREPARED BY: (Signature and Title of Contractors Representative)									9. DATE		10. REVIEWED BY: (Signature and Title of State Highway Official)									11. DATE			

Form FHWA- 1391 (Rev. 09-13)

PREVIOUS EDITIONS ARE OBSOLETE

Attachment 9 to Exhibit 9, Part A

[INTENTIONALLY DELETED]

Attachment 10 to Exhibit 9, Part A

Title IV ASSURANCES APPENDIX A

During the performance of this Agreement, the Developer, for itself, its assignees, and successors in interest (hereinafter referred to as the “Developer”) agrees as follows:

- 1. Compliance with Regulations:** The Developer (hereinafter includes consultants) will comply with the acts and the regulations relative to non-discrimination in federally-assisted programs of the FHWA, as they may be amended from time to time, which are herein incorporated by reference and made a part of this Agreement.
- 2. Non-discrimination:** The Developer, with regard to the work performed by it during the Agreement, will not discriminate on the grounds of race, color, or national origin in the selection and retention of Subcontractors, including procurements of materials and leases of equipment. The Developer will not participate directly or indirectly in the discrimination prohibited by the acts and the regulations, including employment practices when the Agreement covers any activity, project, or program set forth in Appendix B of 49 CFR Part 21.
- 3. Solicitations for Subcontracts, Including Procurements of Materials and Equipment:** In all solicitations, either by competitive bidding, or negotiation made by the Developer for work to be performed under a subcontract, including procurements of materials, or leases of equipment, each potential Subcontractor or supplier will be notified by the Developer of the Developer’s obligations under this Agreement and the Acts and the Regulations relative to Non-discrimination on the grounds of race, color, or national origin.
- 4. Information and Reports:** The Developer will provide all information and reports required by the acts, the regulations, and directives issued pursuant thereto and will permit access to its books, records, accounts, other sources of information, and its facilities as may be determined by ADOT or the FHWA to be pertinent to ascertain compliance with such acts, regulations, and instructions. Where any information required of the Developer or a Subcontractor is in the exclusive possession of another who fails or refuses to furnish the information, the Developer will so certify to ADOT and FHWA, as appropriate, and will set forth what efforts it has made to obtain the information.
- 5. Sanctions for Noncompliance:** In the event of Developer’s noncompliance with the Non-discrimination provisions of this Agreement, ADOT will impose such sanctions as it or FHWA may determine to be appropriate, including, but not limited to:
 - a. withholding payments to the Developer under the Agreement until the Developer complies; and/or

b. cancelling, terminating, or suspending the Agreement, in whole or in part.

6. Incorporation of Provisions: The Developer will include the provisions of paragraphs one through six in every subcontract, including procurements of materials and leases of equipment, unless exempt by the Acts, the Regulations and directives issued pursuant thereto. The Developer will take action with respect to any subcontract or procurement as ADOT or FHWA may direct as a means of enforcing such provisions including sanctions for noncompliance. Provided, that if the Developer becomes involved in, or is threatened with litigation by a Subcontractor or supplier because of such direction, the Developer may request ADOT to enter into any litigation to protect ADOT's interests. In addition, the Developer may request the United States to enter into the litigation to protect the interests of the United States.

During the performance of this Agreement, the Developer, for itself, its assignees, and successors in interest (hereinafter referred to as the “Developer”) agrees to comply with the following non-discrimination statutes and authorities; including but not limited to:

Pertinent Non-Discrimination Authorities:

- Title VI of the Civil Rights Act of 1964 (42 U.S.C. § 2000d et seq., 78 stat. 252), (prohibits discrimination on the basis of race, color, national origin); and 49 CFR Part 21.
- The Uniform Relocation Assistance and Real Property Acquisition Policies Act of 1970, (42 U.S.C. § 4601), (prohibits unfair treatment of persons displaced or whose property has been acquired because of Federal or Federal-aid programs and projects);
- Federal-Aid Highway Act of 1973, (23 U.S.C. § 324 et seq.), (prohibits discrimination on the basis of sex);
- Section 504 of the Rehabilitation Act of 1973, (29 U.S.C. § 794 et seq.), as amended, (prohibits discrimination on the basis of disability); and 49 CFR Part 27;
- The Age Discrimination Act of 1975, as amended, (42 U.S.C. § 6101 et seq.), (prohibits discrimination on the basis of age);
- Airport and Airway Improvement Act of 1982, (49 USC § 471, Section 47123), as amended, (prohibits discrimination based on race, creed, color, national origin, or sex);
- The Civil Rights Restoration Act of 1987, (PL 100-209), (Broadened the scope, coverage and applicability of Title VI of the Civil Rights Act of 1964, The Age Discrimination Act of 1975 and Section 504 of the Rehabilitation Act of 1973, by expanding the definition of the terms “programs or activities” to include all of the programs or activities of the Federal-aid recipients, sub-recipients and contractors, whether such programs or activities are Federally funded or not);
- Titles II and III of the Americans with Disabilities Act, which prohibit discrimination on the basis of disability in the operation of public entities, public and private transportation systems, places of public accommodation, and certain testing entities (42 U.S.C. §§ 12131-12189) as implemented by Department of Transportation regulations at 49 C.F.R. parts 37 and 38;
- The Federal Aviation Administration’s Non-discrimination statute (49 U.S.C. § 47123) (prohibits discrimination on the basis of race, color, national origin, and sex);

- Executive Order 12898, Federal Actions to Address Environmental Justice in Minority Populations and Low-Income Populations, which ensures discrimination against minority populations by discouraging programs, policies, and activities with disproportionately high and adverse human health or environmental effects on minority and low-income populations;
- Executive Order 13166, Improving Access to Services for Persons with Limited English Proficiency, and resulting agency guidance, national origin discrimination includes discrimination because of limited English proficiency (LEP). To ensure compliance with Title VI, you must take reasonable steps to ensure that LEP persons have meaningful access to your programs (70 Fed. Reg. at 74087 to 74100);
- Title IX of the Education Amendments of 1972, as amended, which prohibits you from discriminating because of sex in education programs or activities (20 U.S.C. 1681 et seq).

Attachment 11 to Exhibit 9, Part A

PROHIBITION ON REQUIRING CERTAIN INTERNAL CONFIDENTIALITY AGREEMENTS OR STATEMENTS

The Developer shall comply with, and shall cause all Subcontractors to comply with, the requirements of this Attachment 11 to Exhibit 9, Part A (this “Attachment”) pursuant to Federal Acquisition Regulation No. 2023-06, Section 52.209-9.

1. As used in this Attachment:

(a) “Internal Confidentiality Agreement” means a confidentiality agreement or any other written statement that the Developer requires any of its employees or Subcontractors to sign regarding nondisclosure of Developer information, except that it does not include confidentiality agreements arising out of civil litigation or confidentiality agreements that the Developer’s employees or subcontractors sign at the behest of a Federal agency.

(b) “Subcontract” means any contract as defined in subpart 2.1 of FAC 2023-06 entered into by a Subcontractor to furnish supplies or services for performance of the Agreement or a subcontract. It includes but is not limited to purchase orders, and changes and modifications to purchase orders.

(c) “Subcontractor” means any supplier, distributor, vendor, or firm (including a consultant) that furnishes supplies or services to or for Developer or another subcontractor.

2. The Developer shall not require its employees or Subcontractors to sign or comply with Internal Confidentiality Agreements prohibiting or otherwise restricting such employees or Subcontractors from lawfully reporting waste, fraud, or abuse related to the performance of a government contract to a designated investigative or law enforcement representative of a department or agency authorized to receive such information.

3. The Developer shall notify its employees and Subcontractors that prohibitions and restrictions of any preexisting Internal Confidentiality Agreement covered by this Attachment, to the extent that such prohibitions and restrictions are inconsistent with the prohibitions of this Attachment, are no longer in effect.

4. The prohibition in Section 2 of this Attachment does not contravene requirements applicable to Federal Acquisition Regulation Standard Forms 312 and 4414, or any other form issued by a Federal department or agency governing the nondisclosure of classified information.

5. In accordance with section 743 of Division E, Title VII, of the Consolidated and Further Continuing Appropriations Act, 2015, (Pub. L. 113-235), and its successor

provisions in subsequent appropriations acts (and as extended in continuing resolutions) use of funds appropriated (or otherwise made available) is prohibited, if the federal government determines that the Developer is not in compliance with the provisions of this Attachment.

6. The Developer shall include the substance of this Attachment, including this Section 6, in any subcontracts.

Attachment 12 to Exhibit 9, Part A

ADDITIONAL REQUIREMENTS

The Developer shall comply with, and, as applicable, cause each Subcontractor to comply with, the federal Laws in this Attachment 12 to Exhibit 9, Part A.

1. Appendix A to 2 CFR Part 170, Reporting Subaward and Executive Compensation Information.
2. 2 CFR 200.216, Prohibition on Certain Telecommunications and Video Surveillance Services or Equipment.
3. Section 6002 of the Solid Waste Disposal Act, as amended by the Resource Conservation and Recovery Act.
4. 40 U.S.C. Chapter 37, Contract Work Hours and Safety Standards Act, Sections 2 3702 and 3704, as supplemented by 29 CFR Part 5.

The federal Laws listed herein are incorporated in this Agreement by reference.

Attachment 1 to Exhibit 9, Part B

PARTICIPATION IN BOYCOTT OF ISRAEL CERTIFICATION FORM

This Certification is required in response to legislation enacted to prohibit the State from contracting with companies currently engaged in a boycott of Israel. To ensure compliance with A.R.S. § 35-393.01, this form must be completed and returned with any response to the solicitation and any supporting information to assist the State in making its determination of compliance. The Developer understands that this response will become public record and may be subject to public inspection.

Please note that if any of the following apply to the RFP, Agreement, or Developer, then the Developer shall select the “Exempt Solicitation, Contract, or Contractor” option below:

- The RFP or Agreement has an estimated value of less than \$100,000;
- Developer is a sole proprietorship;
- Developer has fewer than 10 employees; or
- Developer is a non-profit organization.

Pursuant to A.R.S. § 35-393.01, public entities are prohibited from entering into contracts “unless the contract includes a written certification that the company is not currently engaged in, and agrees for the duration of the contract to not engage in, a boycott of goods or services from Israel.”

Under A.R.S. § 35-393:

1. “Boycott” means engaging in a refusal to deal, terminating business activities or performing other actions that are intended to limit commercial relations with entities doing business in Israel or in territories controlled by Israel, if those actions are taken either:
 - (a) Based in part on the fact that the entity does business in Israel or in territories controlled by Israel.
 - (b) In a manner that discriminates on the basis of nationality, national origin or religion and that is not based on a valid business reason.
2. “Company” means an organization, association, corporation, partnership, joint venture, limited partnership, limited liability partnership, limited liability company or other entity or business association, including a wholly owned subsidiary,

majority-owned subsidiary, parent company or affiliate, that engages in for-profit activity and that has 10 or more full-time employees.

5. "Public entity" means this State, a political subdivision of this State or an agency, board, commission or department of this State or a political subdivision of this State.

The certification below does not include boycotts prohibited by 50 United States Code Section 4842 or a regulation issued pursuant to that section. See A.R.S. § 35-393.03.

In compliance with A.R.S. § 35-393.01, all offerors must select one of the following:

- The Company does not participate in, and agrees not to participate in during the term of the contract, a boycott of Israel in accordance with A.R.S. § 35-393.01. I understand that my entire response will become public record in accordance with A.A.C. R2-7-C317.
- The Company does participate in a boycott of Israel as described in A.R.S. § 35-393.01.
- Exempt Solicitation, Contract, or Contractor. Indicate which of the following statements applies to this Contract:
 - Solicitation or Contract has an estimated value of less than \$100,000;
 - Contractor is a sole proprietorship;
 - Contractor has fewer than 10 employees; and/or
 - Contractor is a non-profit organization.

Company Name			Signature of Person Authorized to Sign	
Address			Printed Name	
City	State	Zip	Title	Date

Attachment 1 to Exhibit 9, Part B
FORCED LABOR OF ETHNIC UYGHURS BAN
CERTIFICATION FORM

Please note that if any of the following apply to the Developer, then the Developer shall select the “Exempt Contractor” option below:

- Developer is a sole proprietorship;
- Developer has fewer than 10 employees; or
- Developer is a non-profit organization.

Pursuant to A.R.S. § 35-394, written certification is required to show that the company entering into a contract with a public entity does not use the forced labor, or any goods or services produced by the forced labor, or use any contractors, subcontractors, or suppliers that use the forced labor or any goods or services produced by the forced labor of ethnic Uyghurs in the People’s Republic of China.

Under A.R.S. § 35-394:

1. “Company” means an organization, association, corporation, partnership, joint venture, limited partnership, limited liability partnership, limited liability company or other entity or business association, including a wholly owned subsidiary, majority- owned subsidiary, parent company or affiliate, that engages in for-profit activity and that has 10 or more full-time employees.
2. “Public entity” means this State, a political subdivision of this State or an agency, board, commission or department of this State or a political subdivision of this State.

In compliance with A.R.S. §§ 35-394, the Developer must select one of the following:

<input type="checkbox"/>	<p>The Company does not use, and agrees not to use during the term of the contract, any of the following:</p> <ul style="list-style-type: none">• Forced labor of ethnic Uyghurs in the People’s Republic of China;• Any goods or services produced by the forced labor of ethnic Uyghurs in the People’s Republic of China; or• Any Contractors, Subcontractors, or suppliers that use the forced labor or any goods or services produced by the forced labor of ethnic
--------------------------	--

Attachment 3 to Exhibit 9, Part B

IMMIGRATION CERTIFICATION STATEMENT

(Insert Company Letterhead Here)

Contract Number: _____

Consultant Name: _____ Prime Consultant

Immigration Certification Statement

Each prime contractor and each subcontractor must submit the following statement on its company letterhead prior to the execution of the contract. This form must be signed by either (1) an authorized signer; (2) officer of the corporation; or (3) controlling owner of a firm.

I, [NAME], [TITLE], certify, by signing and submitting this statement that (1) I and my firm are aware of the provisions of Arizona Revised Statute Section 41-4401; and (2) to the best of my knowledge and belief, that [COMPANY NAME] is in compliance and will continue to be in compliance with all federal, state and local immigration laws and regulations with respect to the immigration status of all employees under this contract.

I further acknowledge that compliance with the immigration laws and e-verify requirement is a material condition for eligibility to participate in the contract; and failure to comply with respect to any activity under the contract or with respect to any personnel performing or managing work under the contract is a material breach of the contract.

Owner or Corporate Officer

Date

Company Name

Exhibit 10
PROJECT SITES

[To be inserted]

Exhibit 11

AUTHORIZED REPRESENTATIVES

[To be inserted]

Summary report: Litera Compare for Word 11.2.0.54 Document comparison done on 4/8/2024 12:24:03 PM	
Style name: Prefer	
Intelligent Table Comparison: Active	
Original DMS: iw://amedms.americas.global-legal.com/AMECURRENT/755573719/11	
Modified filename: ADOT NEVI Project Agreement - Addendum 2 04.05.2024 (755573719.12).docx	
Changes:	
Add	165
Delete	190
Move From	0
Move To	0
Table Insert	0
Table Delete	0
Table moves to	0
Table moves from	0
Embedded Graphics (Visio, ChemDraw, Images etc.)	0
Embedded Excel	0
Format changes	0
Total Changes:	355