

**NOTICE OF PROPOSED RULEMAKING  
TITLE 17. TRANSPORTATION  
CHAPTER 6. DEPARTMENT OF TRANSPORTATION  
OVERDIMENSIONAL PERMITS**

**PREAMBLE**

<b><u>1. Sections affected</u></b>	<b><u>Rulemaking Action</u></b>
R17-6-101	Amend
R17-6-102	Amend
Table 1	Amend
R17-6-103	Amend
R17-6-104	Amend
R17-6-105	Amend
R17-6-106	Amend
R17-6-107	Amend
R17-6-108	Amend
R17-6-109	Amend
R17-6-110	Amend
R17-6-111	Amend
R17-6-112	Amend
R17-6-113	Amend
R17-6-201	Amend
R17-6-202	Amend
R17-6-203	Amend
R17-6-204	Amend
R17-6-205	Amend
R17-6-206	Amend
Table 2	Amend
R17-6-207	Amend
R17-6-208	Amend
R17-6-209	Amend
R17-6-210	Amend
R17-6-211	New Section
R17-6-212	New Section
Table 6	New Table
Table 7	New Table
R17-6-301	Amend

R17-6-302	Amend
Illustration 1	Amend
R17-6-303	Amend
Illustration 2	Amend
R17-6-304	Amend
Illustration 4	New Illustration
R17-6-305	Amend
R17-6-306	Amend
R17-6-307	Amend
R17-6-308	Amend
R17-6-401	Amend
R17-6-402	Amend
R17-6-403	Amend
R17-6-404	Amend
R17-6-405	Amend
R17-6-406	Amend
R17-6-407	ReNUMBER
R17-6-407	New Section
R17-6-408	Amend
R17-6-409	Amend
R17-6-410	Amend
R17-6-411	Amend
Table 3.01	Amend
Table 3.02	Amend
Table 3.03	Amend
Table 3.04	Amend
Table 3.05	Amend
Table 3.06	Amend
Table 3.07	Amend
Table 3.08	Amend
Table 3.09	Amend
Illustration 3	Amend
R17-6-412	Amend
Table 4	Amend
R17-6-413	Amend
Table 5	Amend
R17-6-414	ReNUMBER

R17-6-414	Amend
R17-6-501	Amend
R17-6-502	Amend
R17-6-503	Amend
R17-6-504	Amend
R17-6-505	Amend

**2. Citations to the agency’s statutory rulemaking authority to include the authorizing statute (general) and the implementing statute (specific):**

Authorizing statutes: A.R.S. §§ 28-366, 28-1103, 28-1104, and 28-7045

Implementing statutes: A.R.S. Title 28, Chapter 3, Articles 18 and 19, and A.R.S. §§ 28-706 and 28-1821

**3. Citations to all related notices published in the *Register* as specified in R1-1-409(A) that pertain to the record of the proposed rules:**

Notice of Rulemaking Docket Opening: 17 A.A.R. 1821, September 16, 2011

**4. The agency’s contact person who can answer questions about the rulemaking:**

Name: John Lindley  
Address: Department of Transportation, Administrative Rules  
1801 W. Jefferson St., Mail Drop 517M  
Phoenix, AZ 85007  
Telephone: (602) 712-8804  
Fax: (602) 712-3373  
E-mail: jlindley@azdot.gov

Please visit the ADOT web site to track progress of this rule and any other agency rulemaking matters at [www.azdot.gov/mvd/mvdrules/index.asp](http://www.azdot.gov/mvd/mvdrules/index.asp).

**5. An agency’s justification and reason why a rule should be made, amended, repealed or renumbered, to include an explanation about the rulemaking:**

The Department of Transportation, in cooperation with industry representatives, the Department of Public Safety, and local law enforcement personnel, is amending its oversize and overweight permit rules to ensure the rules are clear, concise, and understandable. Most of the amendments are technical changes that promote compliance by making the rules easier for the industry to follow. The rule amendments incorporate calculations applicable to tridem axle group configurations on certain routes; incorporate recent reorganizational changes made within the Department; provide further clarification on existing processes for ensuring public safety; clarify the items an oversize or overweight special permit applicant must provide the Department at the time of application; define additional terms and update several outdated definitions, references, and illustrations; and ensure conformity with the rulemaking style and format requirements of the Arizona Administrative Procedure Act, Secretary of State, and Governor’s Regulatory

Review Council. Additionally, this rulemaking addresses all issues identified in the Department's five-year-review report approved by the Governor's Regulatory Review Council June 3, 2008.

**6. A reference to any study relevant to the rules that the agency reviewed and proposes to either rely on or not to rely on in its evaluation of or justification for the rules, where the public may obtain or review each study, all data underlying each study, and any analysis of each study and other supporting material:**

The agency did not review or rely on any study for this rulemaking.

**7. A showing of good cause why the rulemaking is necessary to promote a statewide interest if the rulemaking will diminish a previous grant of authority of a political subdivision of this state:**

Not applicable

**8. The preliminary summary of the economic, small business, and consumer impact:**

The Department is currently in the process of gathering information related to the anticipated economic impact of these rules and welcomes input from its industry partners.

**9. The agency's contact person who can answer questions about the economic, small business and consumer impact statement:**

Name: Eileen Colleran  
Address: Government Relations Office  
Department of Transportation  
206 S. 17th Ave., Mail Drop 140A  
Phoenix, AZ 85007  
Telephone: (602) 712-7685  
Fax: (602) 712-3232  
E-mail: EColleran@azdot.gov

**10. The time, place, and nature of the proceedings to make, amend, repeal, or renumber the rules, or if no proceeding is scheduled, where, when, and how persons may request an oral proceeding on the proposed rules:**

The Department has scheduled the following oral proceeding/public hearing:

Date: *(To be determined)*  
Time: 2:00 p.m.  
Location: 206 S. 17th Ave.  
Phoenix, AZ

All comments should be directed to the person listed under item 4. Oral comments may be made during regular business hours and written comments may be submitted at any time before the close of public record at 5:00 p.m. *(Date to be determined)*.

**11. All agencies shall list other matters prescribed by statute applicable to the specific agency or to any specific rule or class of rules. Additionally, an agency subject to Council review under A.R.S. §§ 41-1052 and 41-1055 shall respond to the following questions:**

**a. Whether the rules require a permit, whether a general permit is used and if not, the reasons why a general permit is not used:**

The rules detail the eligibility, application, and use requirements of a variety of special permits the Department issues to commercial motor carriers for movement of a vehicle or vehicle and load combination that exceeds the maximum size or weight limits provided by statute. These permits are traditional permits specifically authorized by statute. All information the Department requires of an applicant under these rules is necessary for the Department to make informed decisions on how to best facilitate the safe movement of these specialized vehicles and loads throughout the state and to ensure appropriate precautions are in place for the preservation of public safety and transportation infrastructure.

**b. Whether a federal law is applicable to the subject of the rules, whether the rules are more stringent than federal law and if so, citation to the statutory authority to exceed the requirements of federal law:**

The following federal regulations are applicable to the subject of these rules, but the rules are not more stringent than federal law: 23 CFR 658, Appendix C; 23 CFR 658.5; 49 CFR 71.2; 49 CFR 393; 49 CFR 571.119; and 49 CFR 658.5.

**c. Whether a person submitted an analysis to the agency that compares a rule's impact of the competitiveness of business in this state to the impact on business in other states:**

No analysis was submitted to the Department.

There are no other matters prescribed by statute applicable to the Department or to any specific rule or class of rules.

**12. Incorporations by reference and their location in the rules:**

None

**13. The full text of the rules follows:**

**TITLE 17. TRANSPORTATION**  
**CHAPTER 6. DEPARTMENT OF TRANSPORTATION**  
**~~OVERDIMENSIONAL~~ OVERSIZE AND OVERWEIGHT SPECIAL PERMITS**

**ARTICLE 1. GENERAL PROVISIONS**

Section

- R17-6-101. General Provision; Definitions; Time of Day
- R17-6-102. Threshold Dimensions; Exemptions
- Table 1. Threshold Dimensions
- R17-6-103. General ~~Permit~~ Application Procedure for Special Permits
- R17-6-104. ~~Special Class C Permit Application Procedure~~ Additional Permit Requirements and Restrictions; Engineering Analysis
- R17-6-105. Permit Limitation
- R17-6-106. Permit Extension
- R17-6-107. Permit Confiscation
- R17-6-108. ~~Permit Exemption~~ Traffic Control Plan
- R17-6-109. Permit Denial
- R17-6-110. Liability
- R17-6-111. Administrative Hearing
- R17-6-112. Emergency Operation Provision
- R17-6-113. Electronic Access to Local Permit Ordinances and Rules

**ARTICLE 2. SPECIAL PERMIT CLASSES**

- R17-6-201. Class A Oversize and Overweight Special Permit - Specified Non-reducible Vehicle, Load, or Combination
- R17-6-202. Class B Oversize Special Permit - Specified Non-reducible Vehicle and Load Combination
- R17-6-203. Class B<sub>2</sub> - Type R Oversize Recreational Vehicle Special Permit - Commercial Movement
- R17-6-204. Class C Oversize and Overweight Special Permit - Specified Non-reducible Vehicle, Load, or Combination Over Class A Limits
- R17-6-205. Class D Oversize and Overweight Special Permit - Self-propelled Mobile Crane, Drilling Rig, or Similar Specialty Equipment
- R17-6-206. Class E Oversize and Overweight Special Permit - Reducible Multiple Trailer LCVs
- Table 2. Class E ~~Permit Types~~ Longer Combination Vehicle Permits and Issuance Criteria
- R17-6-207. ~~Class F~~ Repealed
- R17-6-208. Class G Overwidth Special Permit - Specified Vehicle or Combination with Reducible Load Over Legal Width
- R17-6-209. Class H Overwidth Special Permit - Specified Vehicle and Watercraft Load Combination

- R17-6-210. Envelope Permit - Non-specific and Non-reducible Vehicle or Load
- R17-6-211. Western Regional Permit
- R17-6-212. Class C Overweight or Oversize and Overweight Special Permit - Tridem Axle Group Configurations
- Table 6. Class C Overweight, or Oversize and Overweight, Special Permit Routes and Restrictions for Tridem Axle Group Configurations
- Table 7. Maximum Permitted Weight Computations: Tridem Axle Group Configurations

### **ARTICLE 3. SAFETY REQUIREMENTS**

- R17-6-301. General Safety Requirements
- R17-6-302. Warning Flag Requirements
- Ill. 1. Warning Flag Configurations
- R17-6-303. Sign Requirements
- Ill. 2. "OVERSIZE LOAD" Sign
- R17-6-304. Lighting Device Requirements
- Ill. 4. Safety Lighting Configurations
- R17-6-305. Escort Vehicles
- R17-6-306. Traffic Control Provisions
- R17-6-307. Projecting ~~Loads~~ Load or Vehicle
- R17-6-308. Permittee or Driver Obligation to Notify Utility Companies of Overheight Transport

### **ARTICLE 4. TRANSPORT ~~RESTRICTIONS~~ PROVISIONS**

- R17-6-401. General Highway Operations
- R17-6-402. Speed Restriction
- R17-6-403. Weather Restriction
- R17-6-404. ~~Urban~~ Metropolitan Curfew Transport Restriction
- R17-6-405. Weekend Transport Allowance
- R17-6-406. Holiday Transport Restriction
- R17-6-407. Route- and Permit-specific Transport Restrictions
- R17-6-408. Continuous Travel
- R17-6-409. ~~Night Movement~~ Transport Restriction
- R17-6-410. Special ~~Manufactured~~ Mobile Home Towing Restriction
- R17-6-411. Maximum Permitted Weights
- Table 3.01. Maximum Permitted Weight Computations: ~~8-foot, 0-inch~~ Axle Width - 8 feet
- Table 3.02. Maximum Permitted Weight Computations: ~~8-foot, 3-inch~~ Axle Width - 8 feet 3 inches
- Table 3.03. Maximum Permitted Weight Computations: ~~8-foot, 6-inch~~ Axle Width - 8 feet 6 inches
- Table 3.04. Maximum Permitted Weight Computations: ~~8-foot, 9-inch~~ Axle Width - 8 feet 9 inches

- Table 3.05. Maximum Permitted Weight Computations: ~~9-foot, 0-inch~~ Axle Width - 9 feet
- Table 3.06. Maximum Permitted Weight Computations: ~~9-foot, 3-inch~~ Axle Width - 9 feet 3 inches
- Table 3.07. Maximum Permitted Weight Computations: ~~9-foot, 6-inch~~ Axle Width - 9 feet 6 inches
- Table 3.08. Maximum Permitted Weight Computations: ~~9-foot, 9-inch~~ Axle Width - 9 feet 9 inches
- Table 3.09. Maximum Permitted Weight Computations: ~~10-foot, 0-inch~~ Axle Width - 10 feet
- III. 3. Overweight Axle Groups
- R17-6-412. Highway-specific ~~Overdimensional Permitted Vehicle~~ Restrictions, Requirements, Conditions, and Allowances - Oversize and Overweight
- Table 4. Permanent ~~Overdimensional Vehicle~~ Highway Restrictions, Requirements, Conditions, and Allowances
- R17-6-413. Page-Lake Powell Area Houseboat Transport Provisions
- Table 5. Page-Lake Powell Area Highways
- ~~R17-6-407~~R17-6-414. Lake-specific Weekend and Holiday Transport Exception

#### **ARTICLE 5. ENVELOPE PERMIT SPECIAL PROVISIONS**

- R17-6-501. Envelope Permit Required Recordkeeping
- R17-6-502. Envelope Permit Suspension Point System
- R17-6-503. Envelope Permit Suspension; Revocation; Enforcement
- R17-6-504. Notice of Point Assessment, Denial, Suspension, or Revocation
- R17-6-505. Envelope Permit Reapplication

## ARTICLE 1. GENERAL PROVISIONS

### **R17-6-101. General Provision; Definitions; Time of Day**

A. General Provision. ~~The Division Director of the Arizona Department of Transportation, Motor Vehicle Division, in cooperation with the Intermodal Transportation Division, The Department~~ shall issue and regulate overdimensional permits oversize and overweight special permits as provided under this Chapter. The Department implements these Sections under ~~the general authority of A.R.S. § 28-1103(B)~~ authority of A.R.S. §§ 28-366, 28-1103, 28-1104, and 28-7045, in collaboration with the Overdimensional Permit Council as prescribed under ~~A.R.S. § 28-1150(C)(3)~~ A.R.S. § 28-1150.

B. Definitions. In addition to the definitions prescribed under A.R.S. ~~§ 28-601~~ §§ 28-101 and 28-601, the following terms apply to this Chapter:

“AASHTO” means the American Association of State Highway Transportation Officials.

“ADOT” means the Arizona Department of Transportation.

“Appurtenance” means any not readily removable manufacturer- or dealer-installed fixture attached to a vehicle or load that increases a peripheral dimension of the vehicle or load.

“Arizona Central Commercial Permits” means the statewide ~~ADOT-MVD~~ ADOT Enforcement and Compliance Division office for ~~overdimensional~~ oversize and overweight permit applications and information:

14370 West Van Buren 1225 N. 25th Avenue

Goodyear, Arizona 85338 Phoenix, Arizona 85009

Voice line: (623) 932-2247 (602) 712-8851

Facsimile: (623) 932-2444 (602) 272-1887

Internet: www.azdot.gov/mvd/index.asp

“Articulated vehicle” has the same meaning as combination vehicle.

“Cargo carrying unit” has the same meaning as prescribed under A.R.S. § 28-1103.

“Certified law enforcement officer” means a person who is an active duty Arizona peace officer standards and training board certified peace officer.

“Class C Maintenance Permit Services” means the statewide ADOT office for oversize and overweight special permit applications and information:

206 S. 17th Avenue, Mail Drop 004R

Phoenix, AZ 85007

Voice: (602) 712-8176 or (602) 712-8280

Fax: (602) 712-3380

Internet: www.azdot.gov

“Combination vehicle” has the same meaning as prescribed under A.R.S. § 28-101, “combination of vehicles,” but excludes a ~~manufactured~~ or mobile home.

“Continuous travel” means to operate a vehicle continuously throughout any 24-hour period, except as provided under R17-6-404.

“Department” means the Arizona Department of Transportation.

~~“Director” means the Arizona Department of Transportation’s Assistant Director for the Motor Vehicle Division, or the Division Director’s designee.~~

~~“Division” means the Arizona Department of Transportation’s Motor Vehicle Division.~~

“ECD” means the Arizona Department of Transportation’s Enforcement and Compliance Division.

“Envelope” has the same meaning as prescribed under A.R.S. § 28-1141, and encompasses the outermost dimensions of a load or vehicle ~~that~~ described under A.R.S. § 28-1144, which does not exceed:

~~Exceed~~ 120 feet in length;

~~Exceed~~ 16 feet in height;

~~Exceed~~ 14 feet in width; or

~~Exceed~~ 250,000 pounds gross weight, or the maximum permitted weight computations for overweight axle group weight distribution as prescribed under R17-6-411, ~~Table 3.01 through Table 3.09; or,~~

~~Have fewer than four axles.~~

“Envelope permit” has the same meaning as prescribed under A.R.S. § 28-1141, which:

Restricts the loads to non-reducible only;<sub>2</sub>

Allows unlimited trips within the permit’s validity period;<sub>2</sub>

Allows the permitted carrier unlimited load changes;<sub>2</sub>

Requires a transported load to meet envelope dimensional criteria;<sub>2</sub>

Restricts operation to certain routes;<sub>2</sub> and

Excludes the transporting of a ~~manufactured or~~ mobile home.

“Established place of business” means a permanent site or location where the business of an ~~overdimensional~~ oversize or overweight special permit holder is conducted.

“Highway” has the same meaning as prescribed under A.R.S. § 28-101, “street” or “highway.”

“Highway feature” means a roadway, structure, traffic control device, right-of-way, or any item connected with highway travel.

~~“ITD” means the Arizona Department of Transportation’s Intermodal Transportation Division.~~

“IFTA license” means an interstate user license issued by an applicant’s base jurisdiction for fuel tax purposes under the International Fuel Tax Agreement as provided under A.R.S. Title 28, Chapter 16, Article 2.

~~“Law enforcement escort” means law enforcement personnel accompanying an overdimensional permitted vehicle in the conduct of normal duties, under contract to a governmental entity, or as required by the Department under this Chapter.~~ a uniformed certified law enforcement officer in a fully marked patrol vehicle that accompanies an oversize or overweight special permitted vehicle.

“LCV” means longer combination vehicle, which has the same meaning as prescribed under 23 CFR 658.5.

“Legal weight” means within the maximum gross weight limitations prescribed under A.R.S. § 28-1100, and R17-6-102, Table 1.

~~“Maintenance Permits Services” means the statewide ADOT MVD office for class C overdimensional permit approval and technical information:~~

~~1225 N. 25th Ave., Mail Drop 524M~~

Phoenix, AZ 85009

Voice line: (602) 712-8280 or 712-8176

Facsimile: (602) 712-3380

~~“Manufactured home” has the same meaning as prescribed under A.R.S. § 41-2142.~~

~~“Metropolitan Phoenix” means the linear distances between all of the following state highway milepost markers:~~

~~Interstate 10: from milepost 133—SR101, to milepost 161—Chandler Boulevard;~~

~~Interstate 17: from milepost 210—SR101, to exit 150A—I 10 junction at 24th Street;~~

~~State Route 51: All;~~

~~US Route 60: from milepost 188—Power Road, to milepost 172—I 10 junction;~~

~~State Route 143: All;~~

~~State Route 153: All; and~~

~~State Route 202: All.~~

~~“Metropolitan Tucson” means the linear distances between all of the following state highway milepost markers:~~

~~Interstate 10: from milepost 242.5—Cortaro Road, to milepost 268—Craycroft Road;~~

~~Interstate 19: from milepost 59 (kilometer post 95)—Valencia, to I 10 junction;~~

~~State Route 77: from milepost 82—Tangerine Road, to I 10 junction; and~~

~~State Route 86: from milepost 166.5—Kinney Road, to I 19B junction.~~

~~“Mobile home” has the same meaning as prescribed under A.R.S. § 28-2001(B)(1) and A.R.S. § 28-2001, which encompasses both a mobile home and a manufactured home as more specifically prescribed under A.R.S. § 41-2142.~~

~~“Mountain Standard Time” means the standard time in Arizona as prescribed under 49 CFR 71 and A.R.S. § 1-242.~~

~~“MVD” means the Arizona Department of Transportation’s Motor Vehicle Division.~~

~~“Non-reducible load or vehicle” has the same meaning as prescribed under 23 CFR 658.5, “nondivisible load or vehicle.”~~

~~“Overdimensional” means any size or weight measurement exceeding a measurement prescribed under R17-6-102, Table 1.~~

“Oversize or overweight special permit” means a form issued to a permittee by the Department as authorization to transport, on a state highway subject to the terms and conditions of the special permit, a vehicle or combination of vehicles of a size or weight of vehicle or load exceeding the maximum size or weight limitations provided under A.R.S. Title 28, Chapter 3, Articles 18 and 19, and R17-6-102, Table 1.

“Oversize or overweight special permitted vehicle” means the vehicle, combination of vehicles, or vehicle and load combination described to the Department, as prescribed under A.R.S. § 28-1104, on application for a special permit, which is subsequently documented by the Department on any oversize or overweight special permit issued under this Chapter.

“Permittee” means a person or entity ~~authorized, under a permit issued by the Department, to transport an overdimensional vehicle or load~~ issued an oversize or overweight special permit by the Department under this Chapter.

“Pounds per inch of tire width” means a measure of load restriction based on rated tire size, which is determined by dividing the weight carried by an axle group, in pounds, by the number of tires in the group and dividing that result by the manufacturer’s rated tire width indicated on the sidewall of the tire. In the absence of sidewall marking, each tire shall comply with the load rating specified in any publication of an organization listed under 49 CFR 571.119, Federal Motor Carrier Safety Standard No. 119.

“Power unit” has the same meaning as prescribed under A.R.S. § 28-1141.

“Public weighmaster” has the same meaning as prescribed under A.R.S. § 41-2051.

“Specified load” means the dimensions and weights a special permit applicant declares to the Department, as provided under A.R.S. § 28-1104, regarding any item or series of items to be transported throughout an entire permit period with no alteration except for exact dimensional duplicate item substitution.

“Sunrise” and “sunset” have the same meaning and daily calculation as prescribed by the United States Naval Observatory (USNO), which:

The Department uses to determine normal permit transport start and stop times as prescribed under R17-6-401; and

An interested person may access on the Internet from the USNO at <http://aa.usno.navy.mil>, or in hardcopy format from the Arizona Central Commercial Permits office.

“Tandem axle” has the same meaning as prescribed under A.R.S. § 28-1100(B).

“Tare weight” means a vehicle’s empty or starting weight.

“TI” means traffic interchange, which is a junction of roadways arranged to allow for the free flow of traffic uninterrupted by crossing traffic routed over or under the main roadway.

“Tridem axle” means any three consecutive axles whose extreme centers are not more than 144 inches apart and are individually attached to, or articulated from, a common attachment to the vehicle including a connecting mechanism designed to equalize the load between axles.

“USDOT number” means the motor carrier identification number, assigned to a company by the U.S. Department of Transportation’s Federal Motor Carrier Safety Administration, preceded by the letters USDOT.

“UX” means a temporary highway or route segment designated by the Department as:

A segment of highway no longer part of the mainline US system of highways, but still owned and maintained by the Department; or

A portion of a US route affected by mining operations and subject to realignment by the mining company as the mine expands operations.

“Watercraft” has the same meaning as prescribed under A.R.S. § 5-301, which is properly registered with the Arizona Game and Fish Department or the U.S. Coast Guard.

- C. Time of Day. In this Chapter, a time of day prescribed is Mountain Standard Time as defined ~~in~~ under subsection (B) except where a state highway traverses a tribal nation that adopts Daylight Saving Time under 49 CFR 71.2.

**R17-6-102. Threshold Dimensions; Exemptions**

- A. ~~Unless a vehicle is exempt under A.R.S. §§ 28-1091(C), 28-1093(D), or 28-1095(A)(6) a vehicle operator shall have an overdimensional permit for a vehicle exceeding any dimension prescribed in Table 1. Unless exempt under this Section, or A.R.S. §§ 28-1091(C), 28-1093(D), or 28-1095(A)(6), a person shall obtain and carry an oversize or overweight special permit issued by the Department under this Chapter, if moving a vehicle or load exceeding any dimension prescribed under Table 1 on a state highway under the jurisdiction of the Department.~~
- B. ~~Except as stated in A.R.S. § 28-1103(E), a vehicle required to carry an overdimensional permit as prescribed under subsection (A)~~ A permittee or driver of an oversize or overweight special permitted vehicle shall comply with any all applicable:
1. ~~Safety requirement~~ requirements prescribed under Article 3 ~~of this Chapter;~~ and
  2. ~~Transport restriction provisions~~ prescribed under Article 4 ~~of this Chapter.~~
- ~~C. The Department shall require a class C permit for an overdimensional vehicle or load over axle weight or heavier than 250,000 pounds that proposes a transport route that crosses any state highway bridge.~~
- ~~D.C. An overdimensional vehicle or load does not require an overdimensional permit if crossing a state highway at a level grade. An oversize or overweight special permit is not required when crossing a state highway at a level grade where no highway structures are involved.~~
- D. An oversize or overweight special permit is not required for snow removal equipment operated by one of the following:
1. An Arizona state agency;
  2. An Arizona county;
  3. An Arizona city; or
  4. An Arizona municipality.
- E. The special permit exemption provided under subsection (D) shall apply only to snow removal equipment traveling on its own wheels and:
1. Operating for the purpose of clearing snow or ice;
  2. Traveling to a facility for repair; or
  3. Traveling to a location used for the purpose of on- or off-loading de-icing materials.
- F. The operator of an oversize or overweight vehicle exempt from the special permit requirement under this Section, shall comply with all applicable safety requirements prescribed under Article 3 unless otherwise provided by statute.

**Table 1. Threshold Dimensions**

A vehicle or load exceeding any tabular measurement requires an overdimensional permit in an applicable class as prescribed under Article 2 of this Chapter. The Department shall issue an applicable class of special permit, as prescribed under Article 2, for each vehicle, or vehicle and load combination, exceeding any of the following maximum limits:

<b>Width (in feet, inches)</b>		
All vehicles on the state highway system as designated by the Transportation Board under A.R.S. § 28-304(A)(2)		8' 6"
<b>Height (in feet, inches)</b>		
All vehicles on the state highway system as designated by the Transportation Board under A.R.S. § 28-304(A)(2)		14'
<b>Length (in feet, inches)</b>		
Straight trucks		40'
Truck tractor semitrailer, semitrailer length	Interstate system	57'
	Other highways	53' per trailer; 65' overall combination
Truck tractor semitrailer, full trailer combination		No overall length limit
Trailers in twin trailer combination		28' 6" per trailer
Vehicle transporter combination		75'
Overhang	Front	3'
	Rear	6'
<b>Weight (in pounds)</b>		
Single axle		20,000
Tandem axle		34,000
Steering axle		20,000
Gross vehicle weight, five axles or more and 51 feet maximum length*		80,000

\*Maximum allowed weight on axle groups is computed by the formula prescribed under A.R.S. § 28-1100(A)(4).

<b><u>Width (A.R.S. § 28-1093)</u></b>		
<u>All vehicles operating on the state highway system designated by the Transportation Board under A.R.S. § 28-304(B)(2)</u>	<u>8' 6" (8' if the maximum width of the route is further restricted under R17-6-412, Table 4)</u>	
<b><u>Height (A.R.S. § 28-1094)</u></b>		
<u>All vehicles operating on the state highway system designated by the Transportation Board under A.R.S. § 28-304(B)(2)</u>	<u>14' (13' 6" if the maximum height of the route is further restricted under R17-6-412, Table 4)</u>	
<b><u>Length (A.R.S. §§ 28-1095 and 28-1097)</u></b>		
<u>Straight trucks</u>	<u>40'</u>	
<u>Truck tractor - semitrailer - semitrailer combination</u>	<u>Interstate system</u>	<u>57' 6" semitrailer</u>
	<u>Other highways</u>	<u>53' trailer; or 65' overall combination</u>
<u>Truck tractor - semitrailer - full trailer combination</u>	<u>28' 6" per trailer</u>	
<u>Vehicle transporter combination</u>	<u>75'</u>	
<u>Overhang</u>	<u>Front</u>	<u>3'</u>
	<u>Rear</u>	<u>6'</u>
<b><u>Weight (A.R.S. § 28-1100)</u></b>		
<u>Allowable weight shall be determined using the listed limits or the manufacturer's weight rating, whichever is less.</u>		
<u>Single axle</u>	<u>20,000 lbs.</u>	
<u>Tandem axle</u>	<u>34,000 lbs.</u>	
<u>Steering axle</u>	<u>20,000 lbs.</u>	
<u>Gross weight; five axles or more</u> <u>Maximum allowable axle group weights are computed using the formula prescribed under A.R.S. § 28-1100(A)(4)</u>	<u>80,000 lbs.</u>	

**R17-6-103. General ~~Permit~~ Application Procedure for Special Permits**

**A.** An applicant for an overdimensional permit shall submit the following information to the Department that includes:

1. Vehicle and load dimensions;
2. Specified load combination;
3. Proof of tare and gross weight;
4. Proof of valid registration that complies with the requirements of A.R.S. § 28-2153;

- ~~5. Documentation of any applicable encroachment permit as prescribed under R17-3-702 if the applicant must temporarily move any state-owned highway feature as part of a planned move; and~~
- ~~6. Documentation of a traffic control plan for the entire proposed trip, if the Department requires traffic control measures as a term for the applicant's overdimensional permit approval.~~
- ~~B. In addition to the requirements in subsection (A), an applicant for a class A or C permit to transport a manufactured home shall submit to the Department written proof of ad valorem tax payment or clearance from the applicable county assessor.~~
- ~~C. Method of application:~~
  - ~~1. An applicant for classes A, B, B-Type R, or D through H shall apply by one of the two following methods:
    - ~~a. Direct electronic data entry by an authorized Department officer; or~~
    - ~~b. A written application form faxed, mailed, or delivered to the Arizona Central Commercial Permits office at the location prescribed under R17-6-101(B)(4).~~~~
  - ~~2. An applicant for an envelope permit shall apply by a written application form faxed, mailed, or delivered to Arizona Central Commercial Permits office at the location prescribed under R17-6-101(B)(4).~~
  - ~~3. In addition to any applicable requirement of this Section, an applicant for a class C permit shall follow the application procedure prescribed under R17-6-104.~~
- ~~D. An applicant for any overdimensional permit shall verify to the Department that all information is correct and accurate.~~
- A. Except as provided under subsection (B) and R17-6-104, a person shall apply and submit applicable fees to the Department for an oversize or overweight special permit using one of the following methods:
  1. Fax, mail, or deliver a written application form to the Arizona Central Commercial Permits office at the location prescribed under R17-6-101;
  2. Complete and submit an application online at [www.azdot.gov](http://www.azdot.gov) or [www.servicearizona.com](http://www.servicearizona.com) if the appropriate class of permit is made available by the Department electronically; or
  3. Submit a written application form to an Arizona port of entry identified by the Department on its Enforcement Compliance Division - Commercial Vehicle Enforcement Services web site.
- B. A person shall apply to the Department for an envelope permit by faxing, mailing, or delivering a written application form to the Arizona Central Commercial Permits office at the location prescribed under R17-6-101.
- C. Unless otherwise provided under this Chapter, an applicant for an oversize or overweight special permit shall provide to the Department, at the time of application, all information the Department needs to issue the appropriate type of permit, including:
  1. Company related information:
    - a. Name of the applicant's principal place of business;
    - b. Name of the applicant's established place of business, at or from which the business is to be conducted;
    - c. Name, phone number, and email address of an official company representative; and

- d. USDOT number;
- 2. Power unit related information:
  - a. Vehicle make, body style, and year;
  - b. Vehicle identification number;
  - c. Unit number assigned;
  - d. License plate number; and
  - e. Base jurisdiction - state of registration;
- 3. Vehicle and load combination related information:
  - a. Trailer plate number(s);
  - b. Total number of axles;
  - c. Overall gross weight;
  - d. Overall length, width, and height; and
  - e. Length of front and rear overhang where applicable;
- 4. Load related information:
  - a. Specific load description;
  - b. State and federal routes requested;
  - c. City of origin and city of destination;
  - d. If the load is overweight:
    - i. Axle spacing measurements;
    - ii. Axle width measurements;
    - iii. Number of tires per axle;
    - iv. Weight measurements per axle; and
    - v. Width of each tire;
  - e. If the load is a mobile home:
    - i. Complete serial number; and
    - ii. Evidence of payment of all applicable ad valorem taxes, as required under A.R.S. § 28-1104, in the form of a 504 tax clearance permit issued by the county in which the mobile home is currently located;
- 5. Proof of valid registration that complies with the requirements of A.R.S. § 28-2153; and
- 6. Proof of a valid IFTA license that complies with the requirements of A.R.S. § 28-5742 where applicable.
- D.** An applicant for an oversize or overweight special permit shall certify to the Department that all information provided on the application is true and correct.
- E.** An applicant requesting a special permit for the movement of a specific non-reducible vehicle and load combination with a dimension that exceeds a class A oversize and overweight special permit limitation prescribed under R17-6-201, shall follow the application procedure prescribed under R17-6-204.
- F.** An applicant requesting a special permit for the movement of a self-propelled mobile crane, drilling rig, or similar specialty equipment shall follow the application procedure prescribed under R17-6-205.

G. An applicant requesting a special permit for the movement of a Longer Combination Vehicle shall follow the application procedure prescribed under R17-6-206.

**R17-6-104. ~~Special Class C Permit Application Procedure~~ Additional Permit Requirements and Restrictions; Engineering Analysis**

~~A. An applicant shall mail or fax a written application for a class C permit to ADOT ITD Maintenance Permits Services to the address in R17-6-101(B)(16).~~

- ~~1. An applicant shall submit a written application on the applicant's letterhead or an application form provided by ADOT ITD Maintenance Permits Services.~~
- ~~2. The application shall contain the following:~~
  - ~~a. Overall dimensions for a vehicle plus its specified load including:~~
    - ~~i. Length;~~
    - ~~ii. Height;~~
    - ~~iii. Width; and~~
    - ~~iv. Width to the outside of axles, excluding load-induced tire bulge; and~~
  - ~~b. A detailed route description or printed map with intended route clearly marked to indicate where the permittee will enter and exit the highway system; and~~
  - ~~e. Calculation of total mileage.~~

~~B. Application for an overweight class C permit. If an applicant's vehicle exceeds weight limits prescribed under R17-6-411, Table 3.01 through 3.09, or exceeds 250,000 pounds, the applicant shall provide the following along with a completed permit application:~~

- ~~1. Vehicle axle spacings;~~
- ~~2. Axle weights;~~
- ~~3. Tires:~~
  - ~~a. Manufacturer designated width, and~~
  - ~~b. Number per axle;~~
- ~~4. Load weight;~~
- ~~5. Tare weight;~~
- ~~6. The load's loaded position;~~
- ~~7. An engineering analysis; and~~
- ~~8. Payment for engineering analysis as prescribed in R17-6-204.~~

A. To promote safe movement of oversize and overweight vehicles, or vehicle and load combinations, the Department's Class C Maintenance Permit Services section shall evaluate each class C special permit application to determine, on a case-by-case basis, whether additional permit requirements or restrictions are appropriate and necessary as a condition of permit approval. The Department's decision to require additional permit restrictions shall be based on its consideration of:

1. Bridge capacities;

2. Load size and weight;
3. Pavement stress;
4. Road width, grade, and condition; and
5. Traffic dynamics of the proposed route.

**C.B.** Engineering analysis. If the Department requires an engineering analysis of a proposed route as a condition of permit approval, and is unable to dedicate the employee resources necessary to timely complete the required analysis, a special permit applicant may obtain an analysis prepared by a non-Department engineer at the applicant's own expense.

1. An engineer registered by the Arizona State Board of Technical Registration in structural or civil engineering, as prescribed under A.R.S. Title 32, Chapter 1, shall prepare an engineering analysis of the proposed route according to industry standards. As prescribed under A.R.S. Title 32, the engineer shall be registered by the Arizona Board of Technical Registration in structural or civil engineering.

2. The special permit applicant shall submit to the Department for review any engineering analysis prepared by a non-Department engineer.

~~2.3. The engineer shall prepare an engineering analysis according to industry standards. The Department shall presume that an An engineering analysis prepared according to the following complies with industry standards:~~

- a. ~~The current AASHTO edition of the Condition Evaluation of Bridges Manual for Bridge Evaluation including all interims, standards, or guidelines;~~
- b. ~~The current AASHTO edition of the Standard Specifications for Highway Bridges Load and Resistance Factor Design (LRFD) - Bridge Design Specifications including all interims, standards, or guidelines; and~~
- c. ~~The ADOT Bridge Practice Guidelines, and applicable standards or guidelines. The ADOT Bridge Load Rating Guidelines and Bridge Design Guidelines.~~

~~3.4. The non-Department engineer shall certify that an applicant's overweight vehicle will not overstress or damage any element of:~~

- a. A highway structure; or
- b. Any other state property.

~~4. If the applicant requests that the Department prepare the engineering analysis, the Department may decline to prepare the analysis and request that the applicant submit an engineering analysis prepared by a non-Department engineer if the Department lacks employee resource availability.~~

**C.** An applicant for a class C special permit shall submit to the Department, at the time of special permit application, all applicable fees prescribed under R17-6-204 for preparation or review of an engineering analysis.

**D.** An applicant for a class C special permit may resubmit an engineering analysis ~~previously~~ approved by the Department within the previous 12 months if:

1. The applicant's vehicle, ~~and load dimensions, and proposed route~~ size and weight are identical to a the previously approved permit application, ~~and;~~
  2. The applicant's proposed route is included within the previously approved route; and
  - ~~2-3.~~ There is no change in condition to a highway structure or other state property.
- E.** The Department shall conduct a separate analysis review and approval ~~procedure~~ process for each engineering analysis submitted under this Section.
- F.** If the applicant's engineering analysis shows that a highway structure will not support the overweight vehicle as requested, the Department shall deny the application for a class C special permit.
- G.** If the Department determines a potential traffic safety risk exists, a class C special permit applicant shall submit to the Department a comprehensive traffic control plan as provided under R17-6-108.
- H.** The Department, the Department of Public Safety, or other law enforcement entity lawfully authorized to provide certified weights, may weigh a class C special permitted vehicle and load exceeding 250,000 pounds, or require the applicant to have the vehicle and load weighed as prescribed under A.R.S. § 28-1102.

**R17-6-105. Permit Limitation**

The Department shall issue ~~overdimensional~~ oversize and overweight special permits for state highways. A permittee shall apply separately with an applicable political subdivision or tribal nation for permission to operate on a county, municipal, or tribal route.

**R17-6-106. Permit Extension**

- A.** Upon request by a permittee, the Department shall authorize ~~an~~ a one-time extension of up to four days for a single-trip permit if:
1. The permittee must exchange a permitted vehicle for another due to mechanical failure; ~~or~~
  2. Movement by the permitted vehicle is delayed by inclement weather.
- B.** ~~An~~ Except as provided under subsection (C), a permit extension authorized under this Section subsection (A) is approved:
1. By signature of an authorized ~~MVD enforcement agent,~~ ECD officer; or
  2. By telephone in an emergency situation, ~~or;~~
  - ~~3. By authorization of ADOT ITD Maintenance Permits Services only for a class C permitted vehicle.~~
- C.** An extension authorized under subsection (A) for a class C special permit is approved only by authorization of Class C Maintenance Permit Services.

**R17-6-107. Permit Confiscation**

~~Under A.R.S. § 28-369, a peace officer may confiscate any overdimensional permit other than an envelope permit if the permittee is cited for a violation under A.R.S. Title 28, Chapter 3, Article 18 or this Chapter.~~

- A. Except as provided under subsection (B), a peace officer designated by the Director under A.R.S. § 28-369 may confiscate an oversize or overweight special permit before its expiration date if the vehicle operator is found to be in violation of a provision of this Chapter or A.R.S. Title 28, Chapter 3, Article 18.
- B. The Director shall retrieve, suspend, or revoke an envelope permit as provided under A.R.S. § 28-1147 if the permit holder is found to be in violation of A.R.S. Title 28, Chapter 3, Article 19, or Article 5 of this Chapter.

**R17-6-108. ~~Permit Exemption~~ Traffic Control Plan**

- ~~A. The Director shall not require an overdimensional permit for equipment operated by one of the following:~~
  - ~~1. The Arizona Department of Transportation;~~
  - ~~2. Another state agency;~~
  - ~~3. An Arizona county;~~
  - ~~4. An Arizona city, or~~
  - ~~5. An Arizona municipality.~~
- ~~B. The exemption under this Section applies only to equipment or a vehicle under subsection (A) that is:~~
  - ~~1. In operation, or~~
  - ~~2. Under transport for repair or operation in a secondary location.~~
- ~~C. Safety restrictions prescribed under Article 3 of this Chapter apply to an overdimensional vehicle or load listed under subsection (A).~~
- ~~D. Any entity or contractor of an entity listed under subsection (A) shall keep load specific written permit exemption by the Department available for inspection by law enforcement.~~
- A. To promote safe movement of oversize and overweight vehicles, or vehicle and load combinations, the Department shall evaluate each class C special permit application to determine, on a case-by-case basis, whether a potential traffic safety risk exists that may require a comprehensive traffic control plan as a condition of permit approval. The Department's decision to require a comprehensive traffic control plan shall be based on its consideration of:
  - 1. Bridge capacities;
  - 2. Load size and weight;
  - 3. Pavement stress;
  - 4. Road width, grade, and condition; and
  - 5. Traffic dynamics of the proposed route.
- B. If the Department determines a potential traffic safety risk exists, a class C special permit applicant shall submit to the Department, at the time of special permit application, a comprehensive traffic control plan prepared as follows:
  - 1. Address each aspect involved with the movement of the proposed load over the entire proposed route;
  - 2. Advise Class C Maintenance Permit Services of all obstructions that may be subject to potential disturbance or damage;
  - 3. Detail all available pullout points located along the proposed route listed by highway and milepost number;

4. Detail how all side traffic will be managed;
  5. Detail how all structures, delineators, foliage, and official traffic control devices will be managed or avoided;
  6. Detail the rate of speed at which the load will travel along the proposed route;
  7. Include the approximate times the load will be in transit; and
  8. Provide a contingency plan to be followed in the event of a breakdown.
- C. As a condition of class C special permit issuance, the Department may require an applicant to coordinate the use of one or more law enforcement escorts as needed to ensure public safety while transporting the proposed load.

#### **R17-6-109. Permit Denial**

The ~~Director~~ Department shall deny an ~~overdimensional~~ oversize or overweight special permit application, or revoke a previously approved special permit, if:

1. The proposed transport route or a structure on the route is:
  - a. Unable to bear the size or weight of the transport vehicle and load according to ~~provisions prescribed under R17-6-411, Table 3.01 through Table 3.09, the maximum permitted weight computations for overweight axle group weight distribution as provided under R17-6-411;~~
  - b. Under repair; or
  - c. Temporarily closed due to a hazard condition listed under R17-6-403(B); ~~or~~
2. An applicant for a permit to move a ~~manufactured~~ mobile home does not provide written proof of ad valorem tax payment or clearance- as required under A.R.S. § 28-1104; or
3. The Department determines that the special permit applicant made a material misrepresentation or misstatement on a permit application.

#### **R17-6-110. Liability**

A ~~permittee shall be liable for any damage caused to a state highway by the overdimensional vehicle or load during transport.~~ A person who operates an oversize or overweight special permitted vehicle and a person who causes the vehicle to be operated shall be liable for any damage caused to a state highway by the oversize or overweight vehicle or load during transport as provided under A.R.S. § 28-1107.

#### **R17-6-111. Administrative Hearing**

R17-1-501 through R17-1-513 apply to any overdimensional permit that is:

1. Denied;
2. Confiscated, or
3. Revoked.

If the Department denies a pending oversize or overweight special permit application, or revokes and confiscates a previously issued special permit, the permittee may appeal the action as provided under 17 A.A.C. 1, Article 5.

**R17-6-112. Emergency Operation Provision**

- A.** In time of statewide or local emergency that affects public welfare or safety, according to general powers under A.R.S. §§ 28-363(A)(5) and 28-364(B), the Director may authorize movement of an ~~overdimensional~~ oversize or overweight vehicle or load without a special permit for purposes of relief or repair.
- B.** Authorization for emergency operation under this Section may be obtained by contacting the Arizona port of entry nearest to the affected area as listed on the Department's web site at [www.azdot.gov](http://www.azdot.gov).

**R17-6-113. Electronic Access to Local Permit Ordinances and Rules**

- A.** A local authority that issues excess size and weight special permits under A.R.S. § 28-1103 and this Chapter, shall make available, to the Arizona Central Commercial Permits office, an Internet web link to where the local authority's current ordinances and rules relating to the excess size and weight special permits can be electronically accessed.
- B.** ~~The Arizona Central Commercial Permits office~~ Department shall immediately post, to ~~the Arizona Central Commercial Permits web site at [www.azdot.gov/mvd/index.asp](http://www.azdot.gov/mvd/index.asp)~~ its web site at [www.azdot.gov](http://www.azdot.gov), each Internet web link provided by a local authority under subsection (A) and A.R.S. § 28-1103.

**ARTICLE 2. SPECIAL PERMIT CLASSES**

**R17-6-201. Class A Oversize and Overweight Special Permit - Specified Non-reducible Vehicle, Load, or Combination**

MVD shall issue a class A permit according to the following schedule:

**A.** The Department shall issue a multiple or single trip class A oversize or overweight special permit according to the following criteria for a specified non-reducible vehicle, combination of vehicles, or vehicle and load combination, which exceeds a dimension prescribed under R17-6-102, Table 1, but does not exceed the maximum permitted weight computations for overweight axle group weight distribution as provided under R17-6-411, or any of the following maximum limits:

Vehicle-load description	A non-reducible specified load over <del>legal threshold as prescribed in a</del> <u>threshold dimension prescribed under R17-6-102, Table 1, to a</u> maximum:	
	Height	16 feet
	Overall length	120 feet
	Width	14 feet
	Weight	250,000 lbs.
Permit option	Single trip: 96-hour maximum	
	Multiple trip: 30-day maximum	
Standard permit fee for weight not exceeding 80,000 pounds (A.R.S. § 28-1105)	Single trip	\$15
	Multiple trip	\$30
Overweight permit fee for weight less than 250,000 pounds but that exceeds legal threshold <del>in</del> <u>under R17-6-102, Table 1</u> (A.R.S. § 28-1105)	Single trip	\$75
	Multiple trip	\$75

**B.** An applicant for a class A oversize or overweight special permit shall apply to the Department and submit appropriate fees using the application procedure provided under R17-6-103.

**C.** A permittee or driver of an oversize or overweight vehicle or load shall not access a route listed under R17-6-412, Table 4, unless operating in full compliance with all indicated restrictions and requirements.

**R17-6-202. Class B Oversize Special Permit - Specified Non-reducible Vehicle and Load Combination**

MVD shall issue a class B permit according to the following schedule:

**A.** The Department shall issue an annual class B oversize special permit according to the following criteria for multiple trips of a specified non-reducible vehicle and load combination that exceeds a dimension prescribed under R17-6-102, Table 1, but does not exceed any of the following maximum limits:

Vehicle-load description	A non-reducible, specified <u>vehicle and load combination</u> (excluding cranes and drill rigs) over <del>legal threshold as prescribed in a threshold</del> <u>dimension prescribed under R17-6-102, Table 1,</u> to a maximum:	
	Height	14 feet; 8 inches
	Overall length	80 feet
	Width	12 feet; 6 inches
	Weight	80,000 lbs.
Permit option	Multiple trip: one year	
Fee (A.R.S. § 28-1105)	\$360	

**B.** An applicant for a class B oversize special permit shall apply to the Department and submit appropriate fees using the application procedure provided under R17-6-103.

**C.** A permittee or driver of an oversize or overweight vehicle or load shall not access a route listed under R17-6-412, Table 4, unless operating in full compliance with all indicated restrictions and requirements.

**R17-6-203. Class B, Type R Oversize Recreational Vehicle Special Permit - Commercial Movement**

MVD shall issue a class B, Type R permit according to the following schedule:

**A.** The Department shall issue an annual class B - Type R oversize special permit according to the following criteria for a commercial transporter of a recreational vehicle that exceeds the width threshold prescribed under A.R.S. § 28-1093 and R17-6-102, Table 1, but does not exceed the following maximum limit:

Vehicle-load description	A dealer, manufacturer, or transporter hauling or driving on behalf of a dealer, manufacturer, or consumer of a recreational vehicle with appurtenances wider than 8 feet; 6 inches
Permit option	For each original permit purchased, up to 24 additional copies of that permit may be issued, all of which are valid for unlimited use by an unlimited number of vehicles throughout a one-year period by the permittee.
Fee (A.R.S. § 28-1105)	\$360 <u>per year</u>

- B.** An applicant for a class B - Type R oversize special permit shall apply to the Department and submit appropriate fees using the application procedure provided under R17-6-103.
- C.** A permittee or driver of an oversize or overweight vehicle or load shall not access a route listed under R17-6-412, Table 4, unless operating in full compliance with all indicated restrictions and requirements.

**R17-6-204. Class C Oversize and Overweight Special Permit - Specified Non-reducible Vehicle, Load, or Combination Over Class A Limits**

MVD shall issue a class C permit according to the following schedule:

- A.** The Department shall issue a single trip class C oversize or overweight special permit according to the following criteria for a specified non-reducible vehicle, combination of vehicles, or vehicle and load combination, which exceeds a dimension prescribed under R17-6-201 or R17-6-307:

<del>Vehicle-load description</del>	<del>A non-reducible load that exceeds dimensions and weights of all other permit classes or proposes operation on a restricted route.</del>	
<del>Permit option—requires pre-approval by ADOT ITD Maintenance Permits Services</del>	<del>Specific applicant-designated load as required under R17-6-104(B)</del>	<del>Single trip only</del>
<del>Standard permit fee</del>	<del>Single trip, height or width no greater than 18 feet</del>	<del>\$30</del>
	<del>Single trip, height or width exceeding 18 feet</del>	<del>\$40</del>
<del>Overweight permit fee</del>	<del>Single trip height or width no greater than 18 feet</del>	<del>\$90</del>
	<del>Single trip, height or width exceeding 18 feet</del>	<del>\$100</del>
<del>Engineering Analysis</del>	<del>Prepared and reviewed by ADOT engineer</del>	<del>\$125 per 50 mile increment of proposed route</del>
	<del>Prepared by non-ADOT engineer, and reviewed by ADOT engineer</del>	<del>\$75 per 50 mile increment of proposed route, reviewed by ADOT engineer</del>

<u>Vehicle-load description</u>	<u>A non-reducible load that exceeds dimensions and weights of all other permit classes or when class C operation is proposed on a route further restricted under R17-6-412, Table 4</u>	
<u>Permit option - requires pre-approval by Class C Maintenance Permit Services</u>	<u>Single trip only</u>	<u>Load shall be specifically described by the applicant as provided under subsection (C) and A.R.S. § 28-1104</u>
<u>Standard permit fees</u> <u>(A.R.S. § 28-1105)</u>	<u>Oversize only</u>	<u>\$15*</u>
	<u>Overweight only</u>	<u>\$75*</u>
	<u>Oversize and overweight</u>	<u>\$75*</u>
<u>*In addition to the standard permit fees above, the Department shall collect the following class C review and analysis fee(s) as applicable to the applicant's proposed vehicle and load configuration:</u>		
<u>Class C review and analysis fee</u> <u>(A.R.S. § 28-1103)</u>	<u>Height or width 18 feet or less</u>	<u>\$15</u>
	<u>Height or width over 18 feet</u>	<u>\$25</u>
<u>Engineering analysis</u> <u>(A.R.S. § 28-1103)</u>	<u>Prepared by non-ADOT engineer, and reviewed by ADOT engineer</u>	<u>\$75 per 50 mile increment of proposed route</u>
	<u>Prepared by ADOT engineer</u>	<u>\$125 per 50 mile increment of proposed route</u>

**B. An applicant for a class C oversize or overweight special permit shall:**

1. Complete a class C special permit application form provided by the Department and available online at [www.azdot.gov](http://www.azdot.gov);
2. Submit the completed class C special permit application, including all information required under subsection (C) and all appropriate fees, to Class C Maintenance Permit Services as provided under R17-6-103, R17-6-104, and R17-6-108, as applicable;
3. Contact all applicable utility and cable companies to verify adequate overhead cable and utility line clearances along the proposed route as required under R17-6-308;
4. Obtain an encroachment permit in advance of the proposed movement as provided under 17 A.A.C. Chapter 3, Article 5, if constructing a fixed or temporary improvement within a state highway right-of-way, or for any activity requiring the temporary use of, or intrusion upon, a state highway right-of-way including a median; and
5. Provide or arrange for the use of additional traffic control devices appropriate for the proposed movement if the Department requires additional traffic control measures as a condition of permit approval to ensure the safety of the motoring public. All additional traffic control devices shall conform to the manual and specifications adopted by the Department under A.R.S. § 28-641.

**C. A complete class C special permit application for the movement of an oversize or overweight load shall:**

1. Indicate the starting and ending points of the proposed route;
  2. Document the specific overall dimensions of the vehicle with its specified load, to include:
    - a. Height;
    - b. Length; and
    - c. Width;
  3. Provide a diagram of the vehicle and specified load illustrating all of the following information:
    - a. Axle spacing;
    - b. Axle weight;
    - c. Axle width;
    - d. Tires per axle;
    - e. Tire width as designated by the manufacturer;
    - f. Maximum width to the outside of the axles, excluding any load-induced tire bulge;
    - g. Load weight; and
    - h. Tare weight;
  4. Provide a comprehensive traffic control plan as provided under R17-6-108 if the Department requires traffic control measures as a condition of permit approval.
  5. Provide the estimated time needed to change out a power unit or other special equipment if the Department, through detailed analysis and as a condition of permit approval, requires the use of an additional power unit or other special equipment to ensure safe movement of the proposed load. The Department's decision to require an additional power unit or other special equipment shall be based on its consideration of the:
    - a. Estimated timing involved with clearing a route after a breakdown;
    - b. Expected weather conditions;
    - c. Proximity and availability of reserve resources;
    - d. Size and weight of the load;
    - e. Traffic dynamics of the proposed route; and
    - f. Width, grade, and condition of the roads.
  6. Provide proof of gross weight in the form of a public weighmaster's certificate of weight and measure issued at a certified public scale if required by the Department after twice denying an application for incorrect weights;
  7. Provide proof of valid registration that complies with the requirements of A.R.S. § 28-2153;
  8. Provide proof of a valid IFTA license that complies with the requirements of A.R.S. § 28-5742, if applicable; and
  9. Any other applicable requirement prescribed under R17-6-104.
- D.** An applicant for a class C oversize or overweight special permit to transport a mobile home shall additionally submit to the Department all appropriate:
1. Serial numbers assigned to the mobile home; and

2. Evidence of payment of all applicable ad valorem taxes, as required under A.R.S. § 28-1104, in the form of a 504 tax clearance permit issued by the county in which the mobile home is currently located.

**E.** A permittee or driver of an oversize or overweight vehicle or load shall not access a route listed under R17-6-412, Table 4, unless operating in full compliance with all indicated conditions and allowances.

**F.** The Department shall require a class C special permit for an overweight vehicle or vehicle and load combination heavier than 250,000 pounds requiring transport on a route that crosses any state highway bridge.

**R17-6-205. Class D Oversize and Overweight Special Permit - Self-propelled Mobile Crane, Drilling Rig, or Similar Specialty Equipment**

MVD shall issue a class D permit according to the following schedule:

**A.** The Department shall issue an annual class D oversize or overweight special permit according to the following criteria for a specified non-reducible self-propelled mobile crane, drilling rig, or similar specialty equipment meeting the dimensional requirements prescribed under R17-6-201, without exceeding the maximum permitted weight computations for overweight axle group weight distribution as provided under R17-6-411:

Vehicle-load description	A self-propelled mobile crane, drilling rig, or <u>similar</u> specialty equipment meeting dimensional requirements prescribed <del>in</del> <u>under</u> R17-6-201.
Permit option	Multiple trip: one year
Fee (A.R.S. § 28-1105)	\$600 <u>per year</u>

**B.** An applicant for a class D oversize or overweight special permit shall submit to the Department, with all appropriate fees, an application form provided by the Department that includes all of the following information:

1. Specific dimensions of the vehicle and load combination, including:

a. A detailed description;

b. A detailed drawing, which illustrates all of the following:

i. Axle spacing;

ii. Axle weight;

iii. Axle width;

iv. Tires per axle;

v. Tire width as designated by the manufacturer;

vi. Maximum width to the outside of the axles, excluding any load-induced tire bulge; and

vii. Load weight;

c. A detailed listing of all equipment to be included, such as counterweights, outriggers, boom position, position of boom dolly, etc.; and

- d. A table of loads supplied by the manufacturer listing component and total weights;
  - 2. Proof of gross weight:
    - a. For an initial application, a public weighmaster's certificate of weight and measure issued at a certified public scale once the vehicle is equipped and set for highway travel; or
    - b. For a renewal application, a certification by the applicant that no dimension has changed and the vehicle does not exceed the originally certified dimensions or weights;
  - 3. Proof of valid registration that complies with the requirements of A.R.S. § 28-2153;
  - 4. Proof of a valid IFTA license that complies with the requirements of A.R.S. § 28-5742 where applicable; and
  - 5. Documentation of any applicable encroachment permit obtained under A.A.C. R17-3-702 if the applicant must temporarily move any state-owned highway feature as part of a planned move.
- C.** Conformance to all permit restrictions and vehicle certification is the sole responsibility of the applicant. Violation of the annual permit in size, weight, length, height, changing the boom position, dolly, or trailer position, or any other restriction stated on the permit will void the annual permit and no fee for the annual permit or portion thereof will be refunded. Annual permits are non-transferable and non-refundable.
- D.** A permittee or driver of an oversize or overweight vehicle or load shall not access a route listed under R17-6-412, Table 4, unless operating in full compliance with all indicated restrictions and requirements.

**R17-6-206. Class E Oversize and Overweight Special Permit - Reducible Multiple Trailer LCVs**

- A.** ~~MVD~~ The Department shall issue a class E oversize or overweight special permit according to the types and restrictions listed ~~in~~ under Table 2 for transporting reducible loads using an LCV consisting of a truck or truck tractor and one or more trailers.
- 1. A person who operates, and a person who causes to be operated, an oversize or overweight special permitted vehicle shall be jointly responsible for meeting all permit requirements; and
  - 2. A person shall not operate any other trailer configuration or multiple trailer combination under the class E special permit unless authorized by the Department and specifically indicated on the permit.
- B.** ~~MVD~~ The Department shall issue a class E oversize or overweight special permit ~~to~~ for an LCV only at ~~a state port of entry as follows~~ the following state ports of entry:
- 1. ~~Fredonia,~~
  - 2. ~~1.~~ Page,
  - 3. ~~2.~~ St. George, or
  - 4. ~~3.~~ Teec Nos Pos.
- C.** An applicant for a class E oversize or overweight special permit shall submit to the Department, with all appropriate fees, an application form provided by the Department that includes all of the following information:
- 1. Specific dimensions of the vehicle and load combination;
  - 2. Proof of valid registration that complies with the requirements of A.R.S. § 28-2153;

3. Proof of a valid IFTA license that complies with the requirements of A.R.S. § 28-5742 where applicable; and
4. Other information as needed by the Department to issue an appropriate permit, which shall include:
  - a. Company name;
  - b. Company address;
  - c. Company USDOT #;
  - d. Company mailing address (or terminal information);
  - e. Company contact name, address, telephone number, and fax number or email address;
  - f. Company representative's name and title; and
  - g. Specific routes requested.

**C.D. A** The operator of a class E special permitted LCV shall comply with A.R.S. § 28-1100(A)(4) and not exceed the maximum permitted weight computations for overweight axle group weight distribution as provided under the federal bridge formula or any other applicable state highway restriction, condition, or allowance prescribed by the Department under R17-6-412, Table 4.

**Table 2. Class E Permit Types Longer Combination Vehicle Permits and Issuance Criteria**

<b>Type</b>	<b>Length</b>	<b>Permit Routes</b>	<b>Gross Weight in Pounds</b>	<b>Fee</b>
A	92 feet	All of I-15 and within 20 miles of the Arizona-Utah state line on US-89, US89A, SR98, US160, US163, and SR389	111,000	\$360 per year
B	92 feet	US-64, US89A, US160, US163, and SR389 within 20 miles of the Arizona-Utah state line	121,000 on 9 axles; 123,500 on 10 axles	\$360 per year
C	105 feet on I-15 92 feet other routes	All of I-15 and within 20 miles of the Arizona-Utah state line on US-89, US89A, US160, US163, and SR389	111,000	\$75 per single trip and 30 day; or \$360 per year
D	105 feet	I-15 only	129,000	\$75 per single trip and 30 day; or \$600 per year

See Table 4 under R17-6-412 for approved highways.

<b>LCV Combination - Double: Truck Tractor and Two Trailing Units (23 CFR 658, App. C)</b>					
<b>(Operations may be restricted or prohibited by the Department during periods when traffic, weather, or other safety considerations make such operations unsafe or inadvisable)</b>					
Route	Locations Authorized for LCV Travel Under 23 CFR 658, App. C	Special Movement Restrictions:	Class E Permit Category - Maximum Overall Gross Weight of the Vehicle Combination	Duration and Fee (A.R.S. § 28-1105)	Length Not to Exceed
I-15	MP 0.00 (Nevada State Line) to MP 29.40 (Utah State Line)	Subject to Federal Bridge Formula B limits; and Drive only in the right-hand traffic lane.	A - 80,001 lbs through 111,000 lbs; B - 121,000 lbs for 9 axles; or 123,500 lbs for 10 axles; C - 80,001 lbs through 111,000 lbs; C - 80,001 lbs through 111,000 lbs; D - 111,001 lbs through 129,000 lbs; D - 111,001 lbs through 129,000 lbs.	Annual - \$360 Annual - \$360 Single or 30-Day - \$75 Annual - \$360 Single or 30-Day - \$75 Annual - \$600	95' - Cargo Carrying
US 89	MP 536.99 to MP 556.99 (Utah State Line)	Subject to Federal Bridge Formula B limits; and Drive only in the right-hand traffic lane.	A - 80,001 lbs through 111,000 lbs; B - 121,000 lbs for 9 axles; or 123,500 lbs for 10 axles; C - 80,001 lbs through 111,000 lbs; D - 111,001 lbs through 129,000 lbs; D - 111,001 lbs through 129,000 lbs.	Annual - \$360 Annual - \$360 Single or 30-Day - \$75 Single or 30-Day - \$75 Annual - \$600	95' - Cargo Carrying
US 160	MP 393.57 (Junction US 163 at Kayenta) to MP 470.00 (New Mexico State Line)	Subject to Federal Bridge Formula B limits; and Drive only in the right-hand traffic lane.	A - 80,001 lbs through 111,000 lbs; C - 80,001 lbs through 111,000 lbs; D - 111,001 lbs through 129,000 lbs; D - 111,001 lbs through 129,000 lbs.	Annual - \$360 Single or 30-Day - \$75 Single or 30-Day - \$75 Annual - \$600	95' - Cargo Carrying
US 163	MP 393.52 (Junction US 160 at Kayenta) to MP 416.71 (Utah State Line)	Subject to Federal Bridge Formula B limits; and Drive only in the right-hand traffic lane.	A - 80,001 lbs through 111,000 lbs; C - 80,001 lbs through 111,000 lbs; D - 111,001 lbs through 129,000 lbs; D - 111,001 lbs through 129,000 lbs.	Annual - \$360 Single or 30-Day - \$75 Single or 30-Day - \$75 Annual - \$600	95' - Cargo Carrying
<b>LCV Combination - Triple: Truck Tractor and Three Trailing Units (23 CFR 658, App. C)</b>					
<b>(Operations may be restricted or prohibited by the Department during periods when traffic, weather, or other safety considerations make such operations unsafe or inadvisable)</b>					
Route	Locations Authorized for LCV Travel Under 23 CFR 658, App. C	Special Movement Restrictions:	Class E Permit Category - Maximum Overall Gross Weight of the Vehicle Combination	Duration and Fee (A.R.S. § 28-1105)	Length Not to Exceed

**ODPC Final Draft -  
(10/21/2011)**

Not yet approved or proposed

I-15	MP 0.00 (Nevada State Line) to MP 29.40 (Utah State Line)	Subject to Federal Bridge Formula B limits; and Drive only in the right-hand traffic lane.	A - 80,001 lbs through 111,000 lbs; C - 80,001 lbs through 111,000 lbs; C - 80,001 lbs through 111,000 lbs; D - 111,001 lbs through 129,000 lbs; D - 111,001 lbs through 129,000 lbs.	Annual - \$360 Single or 30-Day - \$75 Annual - \$360 Single or 30-Day - \$75 Annual - \$600	95' - Cargo Carrying
US 89	MP 536.99 to MP 556.99 (Utah State Line)	Subject to Federal Bridge Formula B limits; and Drive only in the right-hand traffic lane.	A - 80,001 lbs through 111,000 lbs; B - 121,000 lbs for 9 axles; or 123,500 lbs for 10 axles; C - 80,001 lbs through 111,000 lbs; C - 80,001 lbs through 111,000 lbs.	Annual - \$360 Annual - \$360 Single or 30-Day - \$75 Annual - \$600	95' - Cargo Carrying
US 160	MP 393.57 (Junction US 163 at Kayenta) to MP 470.00 (New Mexico State Line)	Subject to Federal Bridge Formula B limits; and Drive only in the right-hand traffic lane.	A - 80,001 lbs through 111,000 lbs; B - 121,000 lbs for 9 axles; or 123,500 lbs for 10 axles; C - 80,001 lbs through 111,000 lbs; C - 80,001 lbs through 111,000 lbs.	Annual - \$360 Annual - \$360 Single or 30-Day - \$75 Annual - \$600	95' - Cargo Carrying
US 163	MP 393.52 (Junction US 160 at Kayenta) to MP 416.71 (Utah State Line)	Subject to Federal Bridge Formula B limits; and Drive only in the right-hand traffic lane.	A - 80,001 lbs through 111,000 lbs; B - 121,000 lbs for 9 axles; or 123,500 lbs for 10 axles; C - 80,001 lbs through 111,000 lbs; C - 80,001 lbs through 111,000 lbs.	Annual - \$360 Annual - \$360 Single or 30-Day - \$75 Annual - \$600	95' - Cargo Carrying
<b>LCV Combination - Double: Truck or Truck Tractor, a Semitrailer, and One Full Trailer Combination (A.R.S. § 28-1103)</b> <b>(Operations may be limited by the Director)</b>					
Route	Locations Authorized for LCV Travel Under A.R.S. § 28-1103	Special Movement Restrictions:	Class E Permit Category - Maximum Overall Gross Weight of the Vehicle Combination	Duration and Fee (A.R.S. § 28-1105)	Length Not to Exceed
State 98	MP 294.67 (Junction US 89) to MP 314.67	Subject to Federal Bridge Formula B limits; and Drive only in the right-hand traffic lane.	A - 80,001 lbs through 111,000 lbs.	Annual - \$360	95' - Cargo Carrying
State 389	MP 0.00 (Utah State Line) to MP 32.60 (Junction US 89A)	Subject to Federal Bridge Formula B limits; and Drive only in the right-hand traffic lane.	A - 80,001 lbs through 111,000 lbs.	Annual - \$360	95' - Cargo Carrying
US 89A	MP 609.23 (Junction SR 389) to MP 613.03 (Utah State Line)	Subject to Federal Bridge Formula B limits; and Drive only in the right-hand traffic lane.	A - 80,001 lbs through 111,000 lbs.	Annual - \$360	95' - Cargo Carrying

**R17-6-207. ~~Class F Repealed~~**

MVD shall issue a class F permit according to the following schedule:

Vehicle load description	<del>Overheight: Applicable only to a reducible load transport on a 13-foot, 6-inch height restricted highway. Maximum permitted height: 14 feet, all other dimensions within thresholds prescribed in R17-6-102, Table 1</del>	
Permit option	Single trip: 96-hour maximum	
	Multiple trip: one year	
Fee	Single trip	\$15
	Multiple trip	\$45

**R17-6-208. Class G Overwidth Special Permit - Specified Vehicle or Combination with Reducible Load Over Legal Width**

MVD shall issue a class G permit according to the following schedule:

A. The Department shall issue an annual, 30-day, or single trip class G overwidth special permit according to the following criteria for a specified vehicle, or vehicle combination, with a reducible load that exceeds only the width threshold prescribed under R17-6-102, Table 1, but does not exceed the following maximum limit:

Vehicle-load description	<del>Overwidth: A reducible, specified load exceeding legal width threshold as prescribed in R17-6-102, Table 1 to a maximum of ten feet</del> <u>A specified reducible load, which exceeds only the legal width threshold provided under R17-6-102, Table 1, but does not exceed 10 feet in width</u>	
Permit option	Single trip: 96-hour maximum	
	Multiple trip: 30-day maximum	
	Multiple trip: one year	
Fee ( <u>A.R.S. § 28-1105</u> )	Single trip	\$15
	Multiple trip, 30 day	\$30
	Multiple trip, one year	\$360

- B.** An applicant for a class G overwidth special permit shall apply to the Department and submit appropriate fees using the application procedure provided under R17-6-103.
- C.** A permittee or driver of an oversize or overweight vehicle or load shall not access a route listed under R17-6-412, Table 4, unless operating in full compliance with all indicated restrictions and requirements.

**R17-6-209. Class H Overwidth Special Permit - Specified Vehicle and Watercraft Load Combination**

MVD shall issue a class H permit according to the following schedule:

- A.** The Department shall issue an annual class H overwidth special permit according to the following criteria for multiple trips of a specified vehicle and watercraft load combination that exceeds the width threshold established under A.R.S. § 28-1093 and R17-6-102, Table 1:

Vehicle-load description	<del>A</del> <u>Applicable only to a specified watercraft load registered with Arizona Game &amp; Fish or U.S. Coast Guard that is no wider than <del>ten</del> 10 feet and within all other <u>threshold</u> dimensions <del>within thresholds</del> prescribed in <u>under</u> R17-6-102, Table 1</u>
Permit option	Multiple trip: one year
Fee (A.R.S. § 28-1103)	\$45

- B.** An applicant for an annual class H overwidth watercraft special permit shall apply to the Department and submit appropriate fees using the application procedure provided under R17-6-103.
- C.** In addition to the application procedure provided under R17-6-103, an applicant for an annual class H overwidth watercraft special permit shall submit to the Department proof of a valid watercraft registration or assigned watercraft registration number issued by the Arizona Game and Fish Department or U.S. Coast Guard.
- D.** A permittee or driver of an oversize or overweight vehicle or load shall not access a route listed under R17-6-412, Table 4, unless operating in full compliance with all indicated restrictions and requirements.

**R17-6-210. Envelope Permit - Non-specific and Non-reducible Vehicle or Load**

- A.** ~~MVD shall issue an envelope permit according to the following schedule:~~ The Department shall issue an annual or 30-day oversize envelope permit, or an annual or 30-day oversize and overweight envelope permit, according to the following criteria for a non-specific and non-reducible vehicle or load that meets the definition of envelope permit under R17-6-101, and does not exceed the maximum permitted weight computations for overweight axle group weight distribution as provided under R17-6-411:

Vehicle-load description	<del>A load meeting the description under envelope permit definitions in R17-6-101(9) and (10)</del> <u>A non-specific and non-reducible vehicle or load that meets the definition of envelope permit under R17-6-101 and is within the maximum permitted weights provided under R17-6-411</u>	
Permit option	30-day oversize only	
	30-day <u>oversize and</u> overweight	
	Annual oversize only	
	Annual oversize and overweight	
Fee ( <u>A.R.S. § 28-1143</u> )	30-day oversize only	\$150
	30-day <u>oversize and</u> overweight	\$500
	Annual oversize only	\$750
	Annual oversize and overweight	\$1,500

**B.** An applicant for an oversize, or oversize and overweight, envelope permit shall apply to the Department and submit appropriate fees using the application procedure provided under R17-6-103.

**B.C.** ~~MVD~~ The Department shall assess an additional service charge for:

1. A modified permit duplicate: \$25; and
2. Each additional power unit exceeding the original number of permitted power units: \$50.

**D.** A permittee or driver of an oversize or overweight vehicle or load shall not access a route listed under R17-6-412, Table 4, unless operating in full compliance with all indicated restrictions and requirements.

**R17-6-211. Western Regional Permit**

**A.** The Department shall issue a western regional permit for movement of a specified vehicle, combination of vehicles, or vehicle and load combination, which meets the specific non-reducible size and weight criteria established under the Western Regional Agreement for travel in Arizona and any other jurisdiction that is a party to the Western Regional Agreement. The western regional permit eliminates the need to obtain a separate permit for each jurisdiction.

**B.** An applicant is eligible for the western regional permit provided under subsection (A), if the applicant's vehicle, combination of vehicles, or vehicle and load combination meets all of the following criteria:

1. Non-reducible;

3. Specifically described;
  4. Width is 14 feet or less;
  5. Height is 14 feet or less;
  6. Length is 110 feet or less;
  7. Overall gross weight is 160,000 pounds or less;
  8. 600 pounds per inch of tire width;
  9. A minimum of five axles; and
  10. The weights of any group of axles are determined using the lesser of the vehicle weights provided by the tables in the Western Regional Manual or the following:
    - a. 21,500 pounds per single axle;
    - b. 43,000 pounds per tandem axle group; or
    - c. 53,000 pounds per tridem axle group (wheel base is more than eight feet but not more than 13 feet).
- C.** An applicant with a vehicle, combination of vehicles, or vehicle and load combination meeting all eligibility criteria provided under subsection (B), may apply for a western regional permit by completing, and submitting to the Department, a western regional permit application along with:
1. Proof of valid registration in compliance with A.R.S. § 28-2153;
  2. Proof of a valid IFTA license in compliance with A.R.S. § 28-5742, if applicable; and
  3. All applicable fees calculated as provided under the fee schedules located in the Western Regional Manual maintained at the Arizona Central Commercial Permits Office or Ports of Entry.
- D.** The Department shall issue, no more than five days before its effective date, a western regional permit valid for a period of five working days.
- E.** The Department, at the request of a permit holder, may extend the western regional permit's period of validity for up to five days, if completion of the trip is precluded by weather, road conditions, or mechanical failure. An extension authorized by the Department under this Section shall be approved:
1. By signature of an authorized ECD agent,
  2. By telephone in an emergency situation, or
  3. By authorization of the Arizona Central Commercial Permits office.

**R17-6-212. Class C Overweight or Oversize and Overweight Special Permit - Tridem Axle Group Configurations**

- A.** The Department may issue a single trip class C overweight, or oversize and overweight, special permit for tridem axle group configurations subject to the specific routes and restrictions provided under Table 6 and the maximum permitted weight computations provided under Table 7.
- B.** An applicant for a single trip class C overweight, or oversize and overweight, special permit for tridem axle group configurations shall apply to the Department using the application procedure provided under R17-6-103, and include the \$75 standard permit fee with the \$15 class C review and analysis fee provided under R17-6-204.

- C.** The single trip Class C overweight, or oversize and overweight, special permit for tridem axle group configurations is restricted to a vehicle with:
1. A minimum of four tires per tridem axle group;
  2. A minimum of eight feet out-to-out axle width for each tridem group;
  3. A minimum of eight feet distance between the center of the first axle and the center of the third axle of each tridem group;
  4. A maximum of two tridem axle groups, or a maximum of one tandem axle group with one tridem axle group, spaced at least 25 feet between the center of the last axle of the front group and the center of the first axle of the rear group, with no other axles in-between the two groups; and
  5. A maximum distance of 12 feet between the center of the first axle and the center of the third axle of each tridem group.
- D.** A tridem axle group may be used in combination with other non-tridem axle groups only if the non-tridem axle groups do not exceed the maximum permitted weight computations for overweight axle group weight distribution under R17-6-411.
- E.** A permit applicant with a vehicle, combination of vehicles, or vehicle and load combination exceeding 14 feet in width, 16 feet in height, 120 feet in length, 140,000 lbs overall gross vehicle weight, or any other dimension specified above shall continue to follow the Department's existing Class C permit application procedures provided under R17-6-204.

**Table 6. Class C Overweight, or Oversize and Overweight, Special Permit Routes and Restrictions for Tridem Axle Group Configurations**

The single trip class C overweight, or oversize and overweight, special permit for tridem axle group configurations may be issued by the Department for travel on State Route 68, US Route 93 from mile post 67 (junction with State Route 68) to mile post 70 (junction with I-40), and Interstates 10, 19, and 40 subject to the following conditions:

<b><u>Route #</u></b>	<b><u>Milepost #</u></b>	<b><u>STR #</u></b>	<b><u>Structure Name</u></b>	<b><u>Restrictions</u></b>
I-10 EB	250.66	391	Rillito Creek Bridge	Travel in the right most lane
I-10 EB	267.65	1044	Earp Wash Tributary Bridge	Travel in the right most lane
I-10 EB	277.46	463	Wash Bridge	Travel in the right most lane
I-10 EB	312.77	574	Sibyl Road TI OP	Exit and bypass
I-10 EB	355.58	429	Monk Draw Bridge	Exit at 352 and merge at 355
I-10 WB	249.49	390	Canada Del Oro Bridge	Travel in the right most lane
I-10 WB	267.65	1045	Earp Wash Tributary Bridge	Travel in the right most lane
I-10 WB	299.14	73	Cornfield Canyon Bridge	Travel in the right most lane
I-10 WB	312.77	575	Sibyl Road TI OP	Exit and bypass
I-10 WB	389.38	210	Island Wash Bridge	Travel in the right most lane
I-40 EB	224.70	321	Babbitt Tank Wash Bridge	Travel in the right most lane

<u>I-40 WB</u>	<u>13.61</u>	<u>377</u>	<u>Franconia Wash Bridge</u>	<u>Travel in the right most lane</u>
<u>I-40 WB</u>	<u>21.01</u>	<u>1312</u>	<u>Flat Top Wash Bridge</u>	<u>Travel in the right most lane</u>
<u>I-40 WB</u>	<u>21.84</u>	<u>364</u>	<u>Happy Jack Wash Bridge</u>	<u>Travel in the right most lane</u>
<u>I-40 WB</u>	<u>23.56</u>	<u>365</u>	<u>Mackenzie Wash Bridge</u>	<u>Travel in the right most lane</u>
<u>I-40 WB</u>	<u>144.31</u>	<u>440</u>	<u>Ash Fork ATSFRR OP</u>	<u>Travel in the right most lane</u>
<u>I-40 WB</u>	<u>148.91</u>	<u>441</u>	<u>Johnson Canyon Bridge</u>	<u>Travel in the right most lane</u>
<u>I-40 WB</u>	<u>278.03</u>	<u>459</u>	<u>Tanner Wash Bridge</u>	<u>Travel in the right most lane</u>
<u>EB = Eastbound, I = Interstate, OP = Overpass, STR # = Structure #, TI = Traffic Interchange, WB = Westbound.</u>				

**Table 7. Maximum Permitted Weight Computations: Tridem Axle Group Configurations**

	<u>Distance between the center of the first axle and the center of the third axle of a tridem group:</u>											
	<u>0"</u>	<u>1"</u>	<u>2"</u>	<u>3"</u>	<u>4"</u>	<u>5"</u>	<u>6"</u>	<u>7"</u>	<u>8"</u>	<u>9"</u>	<u>10"</u>	<u>11"</u>
<u>8'</u>	<u>57,960</u>	<u>58,061</u>	<u>58,161</u>	<u>58,262</u>	<u>58,363</u>	<u>58,463</u>	<u>58,564</u>	<u>58,664</u>	<u>58,765</u>	<u>58,866</u>	<u>58,966</u>	<u>59,067</u>
<u>9'</u>	<u>59,168</u>	<u>59,268</u>	<u>59,369</u>	<u>59,469</u>	<u>59,570</u>	<u>59,671</u>	<u>59,771</u>	<u>59,872</u>	<u>59,973</u>	<u>60,000</u>	<u>60,000</u>	<u>60,000</u>
<u>10'</u>	<u>60,000</u>	<u>60,000</u>	<u>60,000</u>	<u>60,000</u>	<u>60,000</u>	<u>60,000</u>	<u>60,000</u>	<u>60,000</u>	<u>60,000</u>	<u>60,000</u>	<u>60,000</u>	<u>60,000</u>
<u>11'</u>	<u>60,000</u>	<u>60,000</u>	<u>60,000</u>	<u>60,000</u>	<u>60,000</u>	<u>60,000</u>	<u>60,000</u>	<u>60,000</u>	<u>60,000</u>	<u>60,000</u>	<u>60,000</u>	<u>60,000</u>
<u>12'</u>	<u>60,000</u>											



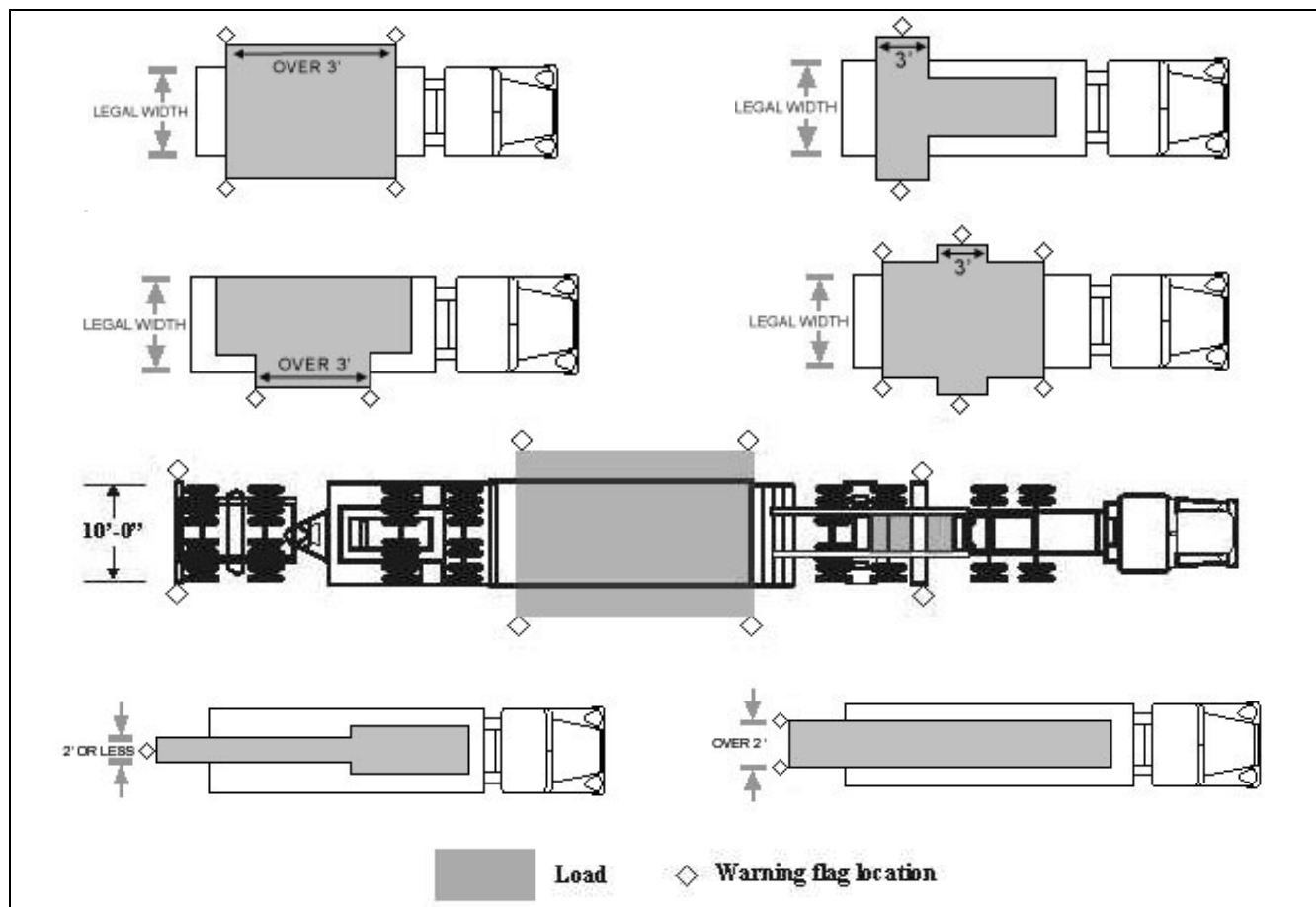

**R17-6-303. Sign Requirements**

- A. A permittee shall ensure that an ~~overdimensional~~ oversize or overweight vehicle or load displays an “OVERSIZE LOAD” sign if the vehicle or load is nine or more feet in width.
  - 1. ~~Is wider than eight feet, six inches;~~ or
  - 2. ~~Transports a load that is nine feet or wider.~~
- B. The Department shall require display of an “OVERSIZE LOAD” sign by any ~~overdimensional~~ oversize or overweight special permitted vehicle or load not specified under subsection (A) if necessary to ensure maximum visibility for safety of the state’s motoring public.
- C. An “OVERSIZE LOAD” sign shall meet construction specifications prescribed under Illustration 2 at a minimum.
- D. A permittee shall display a required “OVERSIZE LOAD” sign that is:
  - 1. Parallel ~~Perpendicular to with~~ the road surface, from side-to-side;
  - 2. Readable from left to right; and
  - 3. Clearly visible from the vehicle’s front and rear.
- E. A permittee of an ~~overdimensional~~ oversize or overweight vehicle or load shall display a required “OVERSIZE LOAD” sign that:

1. Is on the front or roof of the towing vehicle;
  2. Is on the rear of the load or loaded vehicle; and
  3. Complies with subsection (D).
- F. If a permittee required to display an "OVERSIZE LOAD" sign is not transporting an ~~overdimensional~~ oversize or overweight load, the permittee shall ensure each sign is not visible to traffic.

**Illustration 2. "OVERSIZE LOAD" Sign**

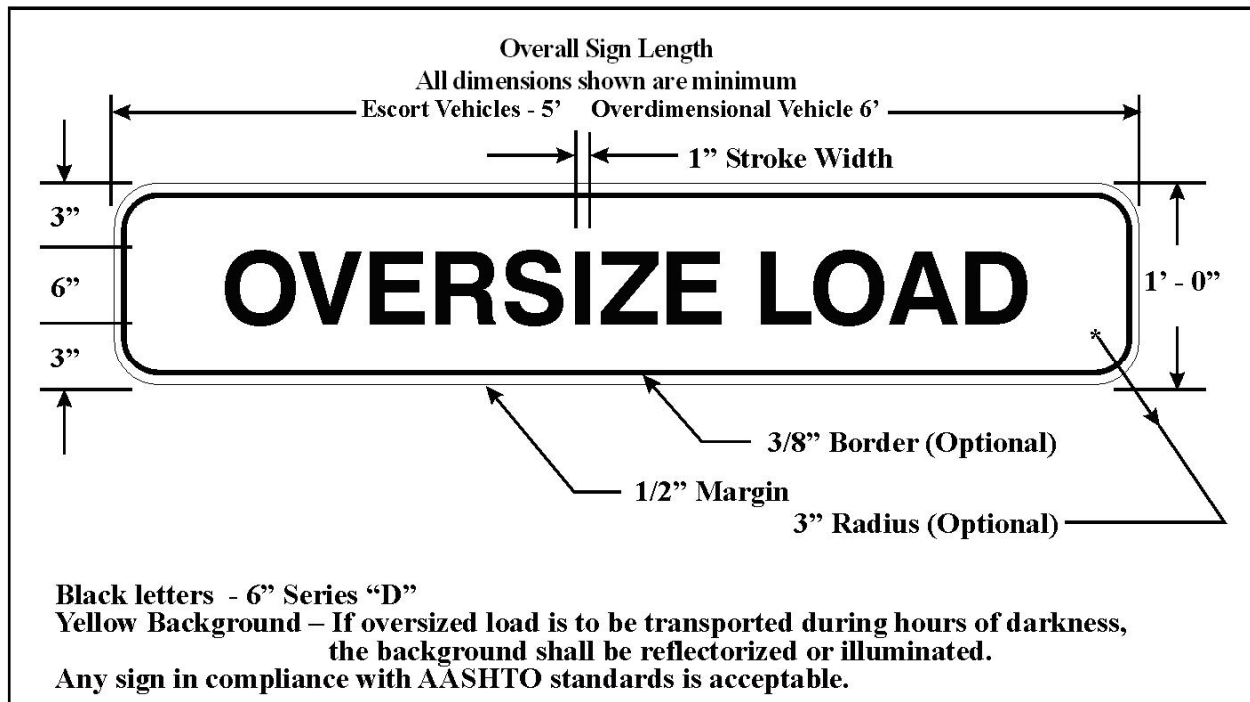

**R17-6-304. Lighting Device Requirements**

- A.** A permittee or driver of an ~~overdimensional~~ oversize or overweight vehicle or load shall:
1. Comply with all applicable lighting equipment requirements ~~of~~ under A.R.S. Title 28, Chapter 3, Article 16, and 49 CFR 393 as incorporated by reference under R17-5-202(A), A.A.C. R17-5-202; and
  2. Operate with the lighting equipment illuminated as prescribed under ~~A.R.S. § 28-922~~ A.R.S. §§ 28-922 and 28-935.
- B.** A permittee or driver of an overwidth load that projects from either side of the vehicle by two feet, when the height of the load is less than 12 inches above the bed of the hauling equipment, or three feet when the height of the load is at least 12 inches above the bed of the hauling equipment, shall attach safety lighting during nighttime operation according to the requirements prescribed under Illustration 4, most closely corresponding to the permittee or driver's vehicle and load configuration.

C. A permittee or driver of an oversize load that projects more than four feet in front or rear overhang shall attach safety lighting during nighttime operation according to the requirements prescribed under Illustration 4, most closely corresponding to the permittee or driver's vehicle and load configuration.

**Illustration 4. Safety Lighting Configurations**

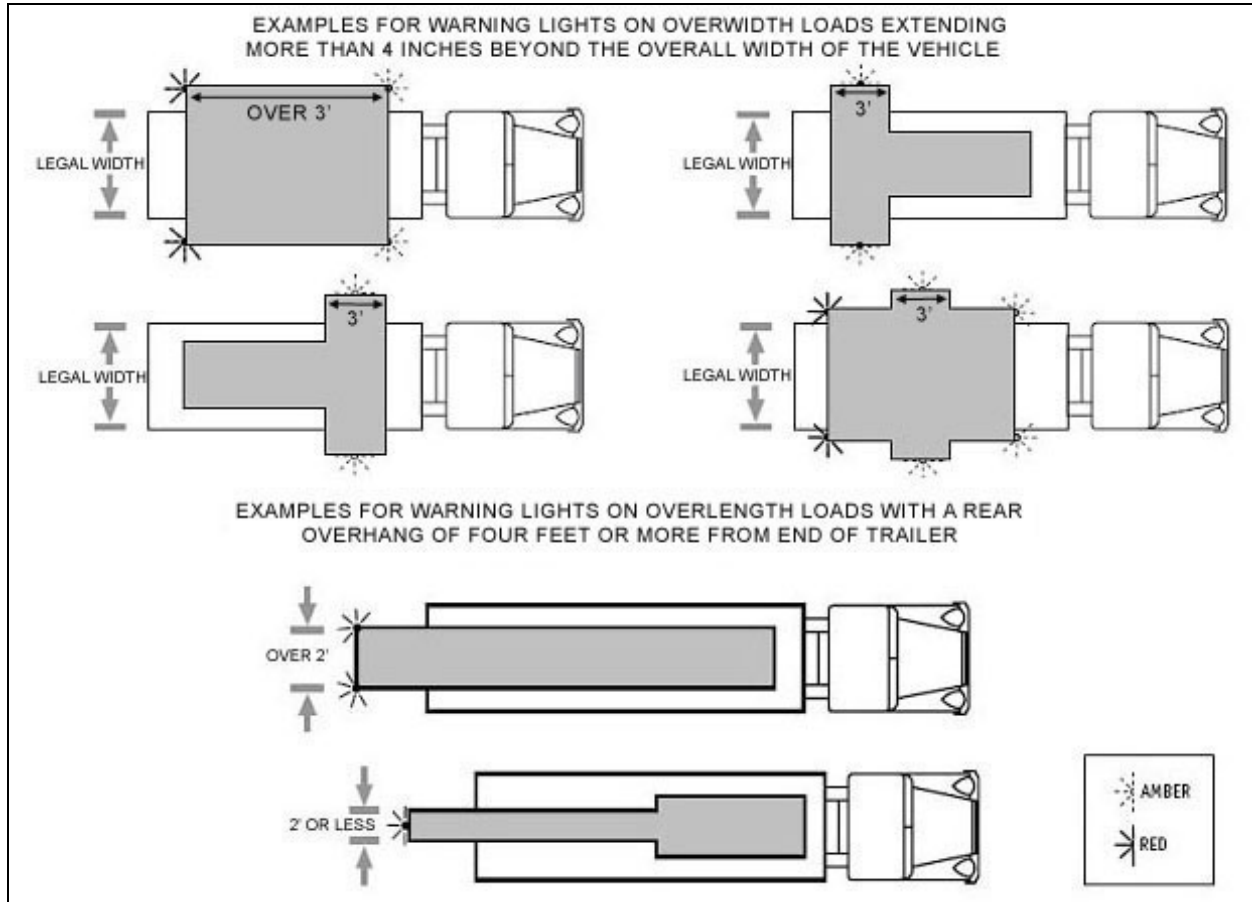

**R17-6-305. Escort Vehicles**

**A. Service requirement.**

1. ~~If required by the Department, a permittee shall have an escort vehicle while transporting an overdimensional vehicle or load on a highway restricted by R17-6-412, Table 4. A permittee shall, as a condition of special permit issuance, employ or contract all escorts required by the Department under R17-6-108(C) and R17-6-412, Table 4, to promote public safety while transporting an oversize or overweight vehicle or load.~~
2. The Department shall determine whether one or more escort vehicles must accompany an ~~overdimensional oversize or overweight special permitted vehicle~~ by considering the following:
  - a. Proposed transport route:
    - i. Highway width, height restrictions, road dynamics;

- ii. Surface condition; and
  - iii. Grade;
  - b. Overall vehicle and load dimensions;
  - c. Need for frequent stops;
  - d. Concern for public safety; ~~and~~
  - e. Time of movement; and
  - f. The most recent version of the best practice guidelines for determining the minimum number and placement of escorts required for oversize and overweight load movements developed by the Overdimensional Permit Council in cooperation with the Department and law enforcement agencies and made available to the public on the Department's web site at [www.azdot.gov](http://www.azdot.gov).
3. According to the criteria applicable under subsection (A)(2), the Department shall require two or more ~~overdimensional~~ oversize or overweight special permitted vehicles traveling together to be accompanied by at least one escort vehicle per load.
- B. Vehicle, operator, and equipment requirements.**
- 1. A vehicle qualifies as an escort vehicle if it:
    - a. Is a passenger car or two-axle truck operating as a single unit; ~~;~~
    - b. Is currently registered; ~~;~~ and
    - c. Meets insurance requirements as provided ~~by~~ under law.
  - 2. An escort vehicle operator, except for a law enforcement escort, shall meet all requirements under A.R.S. § 28-1110, and maintain certification through a program that meets the escort vehicle operator training and certification standards of the Commercial Vehicle Safety Alliance or an equivalent program, whether in this state or another state, that meets the same objectives.
  - ~~3. Effective September 21, 2006, an escort vehicle operator is in compliance with subsection (B)(2), if the escort vehicle operator:~~
    - ~~a. Files an application with a program that meets the escort vehicle operator training and certification standards of the Commercial Vehicle Safety Alliance or an equivalent program that meets the same objectives, whether in this state or another state; and~~
    - ~~b. Completes the training and certification program within 120 days of the date of application.~~
  - ~~4.3.~~ An escort vehicle operator shall possess all of the following equipment:
    - a. Warning flags as prescribed under R17-6-302, when accompanying an ~~overdimensional~~ oversize or overweight special permitted vehicle;
    - b. Warning lights as prescribed under A.R.S. § 28-947(D);
    - c. An "OVERSIZE LOAD" sign:
      - i. Constructed as prescribed under R17-6-303(C);
      - ii. Mounted above the vehicle's roofline;
      - iii. Displayed as prescribed under R17-6-303(D);
      - iv. Accompanied by two flags, one mounted on each side of the oversize load sign; and

- v. Not visible when not in use;
  - d. A two-way radio:
    - i. Capable of transmitting and receiving a minimum of ~~one-half~~ 1/2 mile; and
    - ii. Compatible with each two-way radio in an accompanying escort vehicle and each escorted ~~overdimensional~~ oversize or overweight special permitted vehicle; and
  - e. Emergency equipment to include:
    - i. At least eight emergency warning devices; and
    - ii. Two emergency staff-mounted warning flags manufactured to the specifications prescribed under R17-6-302(A).
- C. Operation.**
- 1. Lighting requirement. While in service, an escort vehicle operator shall maintain continuous illumination of headlights and overhead warning lights.
  - 2. Lead- and follow-distance.
    - a. On an open state highway, except when visual contact cannot be maintained, an escort vehicle operator shall maintain a lead- or follow-distance not exceeding 1,500 feet from the escorted vehicle. **(Clarify)**
    - b. In an urban setting, an escort vehicle operator shall maintain a lead- or follow-distance not exceeding 250 feet from the escorted vehicle.
  - 3. Stop provisions at ~~a traffic signal controlled intersection~~ an intersection with a traffic control signal.
    - a. When an ~~overdimensional~~ oversize or overweight special permitted vehicle is required to stop, the lead-escort vehicle operator shall proceed through the intersection and stop safely off the roadway. The lead-escort vehicle operator shall resume normal lead distance as soon as is safely possible.
    - b. When a following-escort vehicle is required to stop, the operator of an ~~overdimensional~~ oversize or overweight special permitted vehicle shall proceed without stopping. The following-escort vehicle operator shall resume its normal distance behind the ~~overdimensional~~ oversize or overweight special permitted vehicle as soon as is safely possible after clearing an intersection.

**R17-6-306. Traffic Control Provisions**

- A.** The Department may require additional traffic control by ~~the Arizona Department of Public Safety or other means~~ a uniformed certified law enforcement officer to ensure public highway safety. The Department shall consider the criteria under R17-6-305(A) ~~following~~ when determining the need for additional traffic control:
- ~~1. Proposed route;~~
  - ~~2. Vehicle or load dimensions; or~~
  - ~~3. Time of movement.~~
- B.** If the Department requires a law enforcement escort under R17-6-412, Table 4, or as necessary to promote public safety, the permittee or driver of the oversize or overweight special permitted vehicle shall:

1. Contact the Arizona Department of Public Safety to request the appropriate number of uniformed certified law enforcement escorts required for the permitted activity:

If the Arizona Department of Public Safety is unable to timely provide the appropriate law enforcement escorts, the permittee or driver of the oversize or overweight special permitted vehicle may use any uniformed certified law enforcement escorts if at least one officer is certified for enforcement of the Federal Motor Carrier Safety Regulations of the U.S. Department of Transportation's Federal Motor Carrier Safety Administration; and

2. Ensure continuous two-way radio communication with law enforcement and all other escort vehicles required to accompany the permitted vehicle under R17-6-305 and R17-6-307.

### **R17-6-307. Projecting Load or Vehicle**

~~A.~~ The Department shall require a class C permit for any vehicle load that projects more than three feet from the side of the vehicle.

~~B.~~ The Department shall require a class A permit for any vehicle load that projects:

1. ~~No more than three feet from either side of the vehicle when a projecting object has a thickness of 12 inches or greater, or~~
2. ~~No more than two feet from either side of the vehicle when a projecting object is less than 12 inches thick.~~

~~C.~~ A permit applicant for a manufactured home unit under class A shall not have:

1. ~~A measured box width greater than 14 feet, and~~
2. ~~An eave of greater than two feet projecting on the unit's side facing the roadway.~~

A. The Department shall require a class C special permit for a vehicle or load that projects from either side of the hauling equipment more than:

1. Two feet, when the height of the overhanging portion of the load rises less than 12 inches above the bed of the hauling equipment; or
2. Three feet, when the height of the overhanging portion of the load rises 12 inches or more above the bed of the hauling equipment.

~~D.B.~~ ~~Escort vehicle requirement.~~ A permittee of a projecting vehicle ~~with a projecting or~~ load shall have an escort vehicle accompaniment as follows:

1. A front escort vehicle if the front load projection is longer than 20 feet; or
2. A rear escort vehicle if rear projection is longer than 20 feet.

~~E.C.~~ A permittee or driver of a projecting vehicle or load ~~with greater than~~ projecting more than four feet front or rear overhang shall:

1. Attach a warning flag flags to the load during daylight operations, as provided under R17-6-302, for daylight operation; or
2. Attach safety lighting during to the load as provided under R17-6-304, Illustration 4, for nighttime operation.

**F.D.** An integral component removed from a loaded primary object may be transported on the same vehicle bearing the primary object ~~providing~~ provided the component does not cause the hauling unit to exceed:

1. Maximum permitted gross weight;<sub>2</sub>
2. Maximum permitted axle weight;<sub>2</sub> or
3. Maximum permitted width.

**R17-6-308. Permittee or Driver Obligation to Notify Utility Companies of Overheight Transport**

If overhead utility lines extend across the proposed route of a ~~permittee's~~ permittee or driver's vehicle or load ~~that exceeds~~ exceeding the height threshold dimensions prescribed ~~in~~ under R17-6-102, Table 1, the permittee or driver shall notify the responsible utility company of possible disturbance or damage as ~~required by~~ provided under A.R.S. § 40-360.43.

#### **ARTICLE 4. TRANSPORT RESTRICTIONS PROVISIONS**

##### **R17-6-401. General Highway Operations**

- A.** A permittee or driver of an ~~overdimensional vehicle or load~~ oversize or overweight special permitted vehicle shall:
1. Operate no earlier than one-half hour before sunrise and no later than one-half hour after sunset, exact daily times as defined under ~~R17-6-101(B)(21)~~ R17-6-101, except as prescribed ~~in~~ under R17-6-404, R17-6-405, R17-6-408, R17-6-409, or unless the Department:
    - a. Restricts operation on a highway or during a time prescribed under this Article; or
    - b. Grants permit-specific alternate operation hours other than those listed under this subsection as a necessary condition to maintain highway safety;
  2. Operate in the rightmost lane of a multi-lane highway if indicated on the special permit except to overtake and pass another vehicle; and
  3. Maintain a minimum distance of 2,000 feet from ~~another overdimensional~~ any other oversize or overweight special permitted vehicle ~~when~~ traveling on the same highway in the same direction except when passing; and.
  4. ~~Replace any state-owned highway feature moved as a result of the transport of an overdimensional vehicle along a traveled route.~~
- B.** Removal of signs, guardrails or other assets from the right-of-way is not authorized under this permit and is illegal under A.R.S. § 28-7053. A separate encroachment permit issued by the Department is required to enter the right-of-way for these purposes or for any reason other than authorized public travel. The limitations of what activity is authorized while in the right-of-way shall be outlined in the encroachment permit.
- C.** Replacement of any state-owned highway feature moved under an encroachment permit, issued pursuant to 17 A.A.C. Chapter 3, Article 5, as a result of the transport of an oversize or overweight vehicle along a traveled route, shall be detailed on the encroachment permit and completed under Department supervision.
- D.** A permittee or driver of an oversize or overweight special permitted vehicle, prior to commencing transport, shall access and review the most current information on roadway conditions, closures, and restrictions using one of the following methods:
1. Phone inquiry - dial 511; or
  2. Online inquiry - visit [www.az511.gov](http://www.az511.gov).

##### **R17-6-402. Speed Restriction**

- A.** A ~~permittee~~ driver of an ~~overdimensional~~ oversize or overweight vehicle or load shall not exceed the lower maximum speed determined by either of the following:
1. A speed limit printed on an issued permit; or
  2. A highway posted vehicle-specific speed limit.
- B.** The Department may order an alternative speed restriction to prevent:
1. ~~A traffic hazard, or~~

- ~~2. Highway damage.~~
- 1. Hazardous traffic conditions; or
- 2. Damages to highway features.

**R17-6-403. Weather Restriction**

- A. Responsibility. A driver of an oversize or overweight vehicle, or vehicle and load combination, shall:
- 1. ~~A permitted vehicle driver shall determine an unsafe roadway condition from criteria prescribed under subsection (B). Use the criteria prescribed under subsection (B) to identify unsafe roadway conditions and discontinue transport until safe to continue; and~~
  - 2. ~~A permitted vehicle driver shall comply~~ Comply with any all official agency weather-related travel ~~advisory advisories prohibiting overdimensional oversize or overweight transport.~~
- B. Determining conditions. ~~Overdimensional load transport shall not occur according to the following criteria: A driver of an oversize or overweight vehicle, or vehicle and load combination, shall not transport under the following hazardous conditions:~~

<del>Hazard Criterion</del> <u>Hazardous Conditions:</u>	<del>Possible Cause</del> <u>Causes May Include:</u>
Driver visibility range becomes less than 500 feet	<ul style="list-style-type: none"> <li>• Blowing dust</li> <li>• Falling snow</li> <li>• Fog</li> <li>• Heavy rain</li> </ul>
Road surface condition reduces normal traction	<ul style="list-style-type: none"> <li>• Snow</li> <li>• Ice</li> <li>• Flooding</li> </ul>
A load destabilizing condition endangers road surface or traffic	<ul style="list-style-type: none"> <li>• High winds</li> <li>• Falling objects</li> </ul>

**R17-6-404. ~~Urban~~ Metropolitan Curfew Transport Restriction**

- ~~A permittee of a vehicle or load wider than ten feet shall not transport on a non-holiday Monday through Friday in:~~
- 1. ~~Metropolitan Phoenix as defined under R17-6-101(B)(18) during the following hours:~~
    - a. ~~7:00 a.m. to 9:00 a.m., and~~
    - b. ~~4:00 p.m. to 6:00 p.m.~~
  - 2. ~~Metropolitan Tucson as defined under R17-6-101(B)(19) during the following hours:~~
    - a. ~~7:00 a.m. to 9:00 a.m., and~~
    - b. ~~4:00 p.m. to 6:00 p.m.~~

**A.** Unless otherwise provided under this Article, this Section shall apply as provided under subsections (B) and (C) to a special permitted vehicle or load that exceeds 10 feet in width, but does not exceed any of the following dimensions:

1. 16 feet in height;
2. 3 feet in length of front overhang;
3. 10 feet in length of rear overhang;
4. 120 feet in overall length; or
5. 250,000 pounds.

**B.** A permittee or driver of a special permitted vehicle or load described under subsection (A), may transport on a Monday through Friday during curfew hours subject to the following routes and restrictions:

<b><u>Metropolitan Phoenix - Curfew Routes and Restrictions</u></b>		
<b><u>Route</u></b>	<b><u>Restriction Location (MP = Mile Post)</u></b>	<b><u>Width Restrictions During the Curfew Hours of: 7:00 a.m. to 9:00 a.m.; and 4:00 p.m. to 6:00 p.m.</u></b>
<u>SR 202</u>	<u>MP 9.80 (Junction SR 101) to MP 57.24 (Junction I-10)</u>	<u>Over 10' - 12' = Requires rear escort Over 12' - 16' = No transport</u>
<u>SR 101</u>	<u>MP 1.21 (Junction I-10, near 99th Avenue) to MP 61.33 (Junction SR 202)</u>	<u>Over 10' - 12' = Requires rear escort Over 12' - 16' = No transport</u>

**C.** A permittee or driver of a special permitted vehicle or load exceeding any dimension described under subsection (A), shall not transport on a Monday through Friday during curfew hours subject to the following routes and restrictions:

<b><u>Metropolitan Phoenix - Curfew Routes and Restrictions</u></b>		
<b><u>Route</u></b>	<b><u>Restriction Location (MP = Mile Post)</u></b>	<b><u>Width Restrictions During the Curfew Hours of: 7:00 a.m. to 9:00 a.m.; and 4:00 p.m. to 6:00 p.m.</u></b>
<u>I-10</u>	<u>MP 133.98 (Junction SR 101) to MP 161.35 (Junction SR 202, Santan)</u>	<u>Over 10' - 16' = No transport</u>
<u>I-17</u>	<u>MP 193.94 (Beginning of route at Junction I-10) to MP 214.96 (Junction SR 101)</u>	<u>Over 10' - 16' = No transport</u>
<u>SR 51</u>	<u>MP 0.00 (Junctions I-10 and SR Loop 202) to MP 15.90 (Junction SR Loop 101)</u>	<u>Over 10' - 16' = No transport</u>
<u>SR 143</u>	<u>MP 0.00 (Junction I-10) to MP 3.81 (McDowell Road)</u>	<u>Over 10' - 16' = No transport</u>
<u>SR 202</u>	<u>MP 0.00 (Junctions I-10 and SR 51) to MP 9.80 (Junction SR 101)</u>	<u>Over 10' - 16' = No transport</u>
<u>US 60</u>	<u>MP 172.00 (Junction I-10) to MP 190.51 (Junction SR 202)</u>	<u>Over 10' - 16' = No transport</u>
<b><u>Metropolitan Tucson - Curfew Routes and Restrictions</u></b>		
<u>I-10</u>	<u>MP 236.42 (Marana Road) to MP 270.67 (Kolb Road)</u>	<u>Over 10' - 16' = No transport</u>

<u>I-19</u>	<u>MP 59.09 (Valencia Road, Kilometer Post 95.00) to MP 63.09 (Junction I-10)</u>	<u>Over 10' - 16' = No transport</u>
<u>SR 77</u>	<u>MP 68.05 (Junction I-10) to MP 79.48 (Tangerine Road)</u>	<u>Over 10' - 16' = No transport</u>
<u>SR 86</u>	<u>MP 164.04 (Camino Verde Road) to MP 171.44 (Junction I-19)</u>	<u>Over 10' - 16' = No transport</u>
<b><u>Metropolitan Yuma - Curfew Routes and Restrictions</u></b>		
<u>US 95</u>	<u>MP 19.84 (32nd Street East) to MP 31.87 (Avenue 9E)</u>	<u>Over 10' - 16' = No transport</u>
<u>SB 8</u>	<u>MP 0.00 (California State Line) to MP 11.50 (End of route near I-8, east of Yuma)</u>	<u>Over 10' - 16' = No transport</u>

**R17-6-405. Weekend Transport Allowance**

- A.** This Section applies to a permittee of a vehicle or load that does not exceed dimensions as follows: Except as provided under R17-6-414, a permittee or driver of an oversize or overweight special permitted vehicle, ineligible for continuous travel under R17-6-408 due to excess width or height, may transport on a weekend as provided under this Section if the vehicle or vehicle and load combination is:
1. 16 feet wide; Over 10 feet to 16 feet in width, or
  2. 16 feet high; Over 14 feet 6 inches to 16 feet in height, and
  3. 120 feet long; and Otherwise within the limits prescribed under R17-6-408.
  4. 250,000 pounds.
- B.** A permittee or driver of a vehicle or load described in ~~in~~ under subsection (A) shall ~~not~~ may transport on a Saturday or Sunday ~~except~~ as follows:
1. On any non-holiday weekend ~~Saturday or Sunday~~;
  2. From 3:00 a.m. until 12 noon;
  3. On ~~selected~~ select routes as ~~prescribed~~ authorized by the Department for weekend transport under R17-6-412, Table 4; and
  4. With applicable escort accompaniment as prescribed under ~~R17-6-409(C)~~ subsection (D).
- C.** A permittee or driver of a vehicle or load transporting under this Section shall additionally comply with all applicable restrictions and escort vehicle requirements provided under R17-6-412, Table 4.
- D.** Unless the Department requires additional escort vehicles under R17-6-412, Table 4, a permittee or driver of a vehicle or load transporting under this Section shall have escort vehicle accompaniment as follows:
1. Over 11 to 14 feet in width requires a rear escort.
  2. Over 14 to 16 feet in width requires a front and rear escort, and
  3. Over 15 feet in height requires a front escort with a height pole.
- E.** The Department may approve weekend transport under a class C special permit for a vehicle and load combination exceeding the dimensions prescribed under subsection (A) upon determining the exception to be in the best interest of public safety.

**R17-6-406. Holiday Transport Restriction**

- A. ~~The provisions of this Section apply~~ Except as provided under R17-6-414, this Section applies to an  
overdimensional oversize or overweight special permitted vehicle or load with dimensions greater a dimension  
of more than:
1. ~~10 feet wide~~ in width,
  2. ~~14.6 feet high~~ 14 feet 6 inches in height,
  3. ~~10 feet long in front or rear overhang, or~~ 3 feet in length of front overhang,
  4. 10 feet in length of rear overhang, or
  - 4-5. ~~120 feet long~~ in overall length.
- B. A permittee or driver shall not transport an ~~overdimensional~~ oversize or overweight vehicle or load described  
under subsection ~~(A)(1)~~ (A) in Arizona on the following holidays as defined in ~~in~~ under A.R.S. § 1-301:
1. New Year's Day,
  2. Memorial Day,
  3. Independence Day,
  4. Labor Day,
  5. Thanksgiving Day, or
  6. Christmas Day, ~~and,~~
- C. A ~~holiday~~ restriction on transport ~~in~~ for a holiday listed under subsection (B) also includes days before and after  
a holiday as follows:
1. When a holiday occurs on a Friday, transport shall stop ~~on Thursday~~ at 12 noon on the preceding Thursday  
and may resume the following Monday at one-half hour before sunrise, or Monday at 3:00 a.m. if night  
movement is allowed under R17-6-409;
  2. When a holiday occurs on a Saturday or Sunday, transport shall stop ~~on Friday~~ at 12 noon on the preceding  
Friday and may resume the following Monday at one-half hour before sunrise, or Monday at 3:00 a.m. if  
night movement is allowed under R17-6-409;
  3. When a holiday occurs on a Monday, transport shall stop ~~on the preceding Friday~~ at 12 noon on the  
preceding Friday and may resume the following Tuesday at one-half hour before sunrise, or Tuesday at  
3:00 a.m. if night movement is allowed under R17-6-409; and
  4. ~~When a holiday occurs on a Tuesday, Wednesday, or Thursday, transport shall stop at noon of the day~~  
~~before a holiday and may resume on the day after a holiday at one half hour before sunrise, or on the day~~  
~~after a holiday at 3:00 a.m. if night movement is allowed under R17-6-409~~ When a holiday occurs on a  
Tuesday, Wednesday, or Thursday, transport shall stop at 12 noon on the day before the holiday and may  
resume one-half hour before sunrise on the day after the holiday, or at 3:00 a.m. on the day after the  
holiday if night movement is allowed under R17-6-409.
- D. The Department may approve holiday transport under a class C special permit for a vehicle and load  
combination exceeding a dimension prescribed under subsection (A), upon determining the exception to be in  
the best interest of public safety.

**R17-6-407. Route- and Permit-specific Transport Restrictions**

A permittee or driver of a class C oversize or overweight special permitted vehicle or load shall not transport on a Friday from 12 noon until 3:00 a.m. on a route designated by the Department under R17-6-412, Table 4, as being subject to route- or permit-specific transport restrictions.

**R17-6-408. Continuous Travel**

~~A. The Department shall allow continuous travel of an overdimensional vehicle or load that~~ Except as provided under R17-6-404, a permittee or driver of an oversize or overweight special permitted vehicle is eligible for continuous travel under this Section if the vehicle or vehicle and load combination does not exceed ten feet wide, with all other dimensions not to exceed those in Table 1. any of the following dimensions:

1. 10 feet in width;
2. 14 feet 6 inches in height;
3. 3 feet in length of front overhang;
4. 10 feet in length of rear overhang;
5. 120 feet in overall length; or
6. 250,000 pounds.

~~B. Except as prescribed under R17-6-404, the Department shall allow continuous travel of an overdimensional vehicle or load that does not exceed any dimension as follows:~~

- ~~1. 10 feet wide;~~
- ~~2. 14.6 feet high;~~
- ~~3. Ten feet long in front or rear overhang, or~~
- ~~4. Longer than 120 feet overall.~~

~~C.B. Except during any time and location prohibited under R17-6-405 and R17-6-406, the Department shall allow continuous travel of a crane permitted as prescribed under R17-6-205 that does not exceed any dimension as follows~~ Unless otherwise restricted under R17-6-404, R17-6-405, R17-6-406, or R17-6-412, Table 4, a permittee or driver of a self-propelled mobile crane, drilling rig, or similar specialty equipment issued a special permit under R17-6-205, is eligible for continuous travel if the vehicle does not exceed any of the following dimensions:

- ~~1. 11 feet wide in width;~~
- ~~2. 14 feet high in height; and~~
- ~~3. Ten feet in overhang.~~
3. 3 feet in length of front overhang;
4. 10 feet in length of rear overhang;
5. 120 feet in overall length; or
6. 250,000 pounds.

C. A permittee or driver of a vehicle or load transporting under this Section shall additionally comply with all applicable restrictions and escort vehicle requirements provided under R17-6-305 and R17-6-412, Table 4.

**R17-6-409. Night Movement Transport Restriction**

A. This Section applies to a vehicle or load that does not exceed any of the following dimensions. Unless further restricted under this Article, this Section applies to a permittee or driver of an oversize or overweight vehicle, or vehicle and load combination, within the following dimensions:

1. 16 feet wide 16 feet or less in width;
2. 16 feet high 16 feet or less in height;
3. 3 feet or less in length of front overhang;
4. 10 feet or less in length of rear overhang;
- 3-5. 120 feet long or less in overall length; and or
- 4-6. 250,000 pounds or less in overall weight.

B. A permittee or driver of a vehicle or load within limits prescribed described under subsection (A) may transport at night as follows:

1. Beginning at 3:00 a.m. except on any day, route, or time further restricted under R17-6-404 through R17-6-406;
2. On selected select routes prescribed authorized by the Department for night transport under R17-6-412, Table 4; and
3. With applicable escort accompaniment as prescribed under subsection (D).

C. A permittee or driver of a vehicle or load transporting under this Section shall additionally comply with all applicable restrictions and escort vehicle requirements provided under R17-6-412, Table 4.

C.D. A permittee of a vehicle or load transporting under this Section, shall have escort vehicle accompaniment as follows: Unless the Department requires additional escort vehicles under R17-6-412, Table 4, a permittee or driver of a vehicle or load transporting under this Section shall have escort vehicle accompaniment until sunrise as follows:

1. A rear escort for a vehicle or load with dimensions exceeding 11 feet wide to 14 feet wide;
  2. A front and rear escort for a vehicle or load with dimensions exceeding 14 feet 1 inch to 16 feet;
  3. A front escort with a height pole for a vehicle or load with a dimension exceeding 15 feet in height.
1. Over 11 to 14 feet in width requires a rear escort.
  2. Over 14 to 16 feet in width requires a front and rear escort, and
  3. Over 15 feet in height requires a front escort with a height pole.

E. The Department may approve night transport under a class C special permit for a vehicle and load combination exceeding the dimensions prescribed under subsection (A) upon determining the exception to be in the best interest of public safety.

**R17-6-410. Special ~~Manufactured~~ Mobile Home Towing Restriction**

A. A vehicle towing a ~~manufactured~~ mobile home shall have a factory rating that corresponds with the following criteria:

Load measurement criteria	Towing vehicle factory rating
Less than <del>ten</del> <u>10</u> feet <del>wide</del> <u>in width</u> and less than 50 feet <del>long</del> <u>in length</u> , including hitch	<del>1.5 ton</del> <u>1 1/2 tons</u>
Exceeds <del>ten</del> <u>10</u> feet <del>wide</del> <u>in width</u> or exceeds 50 feet <del>long</del> <u>in length</u> , or both	Two <del>ton</del> <u>tons</u> ; four tires per drive axle and minimum <del>99 inch</del> <u>99 inch</u> wheel base

B. A ~~manufactured~~ mobile home transporter shall cover the open side of a ~~manufactured~~ mobile home module with plastic sheeting no thinner than 1.5 mil plus a rigid grillwork backing.

**R17-6-411. Maximum Permitted Weights**

The Department shall use formulas and computations prescribed in Tables 3.01 through 3.09 and Illustration 3 to permit an overdimensional vehicle or load:

A. Except as provided under R17-6-211 and R17-6-212, the Department shall use the formulas and computations provided under Tables 3.01 through 3.09, and Illustration 3, to determine the maximum weights allowed on any combination of axles within the distance between the front and rear axle of a given axle group, up to a maximum of 18 feet, when issuing an oversize or overweight special permit for a non-reducible vehicle or load under this Article.

B. The Department shall use the computations provided under R17-6-212, Table 7, to determine the maximum weights allowed for tridem axle group configurations subject to conditions, restrictions, allowances, and route limitations provided under R17-6-212, Table 6.

**Table 3.01. Maximum Permitted Weight Computations: ~~8 foot, 0 inch~~ Axle Width - 8 Feet**

Overweight Axle Group Chart

Distance between the center of the front axle and the center of the rear axle of a given group.

			Inches											
			0	1	2	3	4	5	6	7	8	9	10	11
Feet	3	A	28,000	28,000	28,000	28,000	28,000	28,000	45,675	45,763	45,850	45,938	46,025	46,113
		B	32,200	32,200	32,200	32,200	32,200	32,200	52,526	52,627	52,728	52,828	52,929	53,029
	4	A	46,200	46,288	46,375	46,463	46,550	46,638	46,725	46,813	46,900	46,988	47,075	47,163
		B	53,130	53,231	53,331	53,432	53,533	53,633	53,734	53,834	53,935	54,036	54,136	54,237
	5	A	47,250	47,338	47,425	47,513	47,600	47,688	47,775	47,863	47,950	48,038	48,125	48,213
		B	54,338	54,438	54,539	54,639	54,740	54,841	54,941	55,042	55,143	55,243	55,344	55,444
	6	A	48,300	48,388	48,475	48,563	48,650	48,738	48,825	48,913	49,000	49,088	49,175	49,263
		B	55,545	55,646	55,746	55,847	55,948	56,048	56,149	56,249	56,350	56,451	56,551	56,652
	7	A	49,350	49,438	49,525	49,613	49,700	49,788	49,875	49,963	50,050	50,138	50,225	50,313
		B	56,753	56,853	56,954	57,054	57,155	57,256	57,356	57,457	57,558	57,658	57,759	57,859
	8	A	50,400	50,488	50,575	50,663	50,750	50,838	50,925	51,013	51,100	51,188	51,275	51,363
		B	57,960	58,061	58,161	58,262	58,363	58,463	58,564	58,664	58,765	58,866	58,966	59,067
	9	A	51,450	51,538	51,625	51,713	51,800	51,888	51,975	52,063	52,150	52,238	52,325	52,413
		B	59,168	59,268	59,369	59,469	59,570	59,671	59,771	59,872	59,973	60,073	60,174	60,274
	10	A	52,500	52,588	52,675	52,763	52,850	52,938	53,025	53,113	53,200	53,288	53,375	53,463
		B	60,375	60,476	60,576	60,677	60,778	60,878	60,979	61,079	61,180	61,281	61,381	61,482
	11	A	53,550	53,638	53,725	53,813	53,900	53,988	54,075	54,163	54,250	54,338	54,425	54,513
		B	61,583	61,683	61,784	61,884	61,985	62,086	62,186	62,287	62,388	62,488	62,589	62,689
	12	A	54,600	54,688	54,775	54,863	54,950	55,038	55,125	55,213	55,300	55,388	55,475	55,563
		B	62,790	62,891	62,991	63,092	63,193	63,293	63,394	63,494	63,595	63,696	63,796	63,897
	13	A	55,650	55,738	55,825	55,913	56,000	56,088	56,175	56,263	56,350	56,438	56,525	56,613

	B	63,998	64,098	64,199	64,299	64,400	64,501	64,601	64,702	64,803	64,903	65,004	65,104
14	A	56,700	56,788	56,875	56,963	57,050	57,138	57,225	57,313	57,400	57,488	57,575	57,663
	B	65,205	65,306	65,406	65,507	65,608	65,708	65,809	65,909	66,010	66,111	66,211	66,312
15	A	57,750	57,838	57,925	58,013	58,100	58,188	58,275	58,363	58,450	58,538	58,625	58,713
	B	66,413	66,513	66,614	66,714	66,815	66,916	67,016	67,117	67,218	67,318	67,419	67,519
16	A	58,800	58,888	58,975	59,063	59,150	59,238	59,325	59,413	59,500	59,588	59,675	59,763
	B	67,620	67,721	67,821	67,922	68,023	68,123	68,224	68,324	68,425	68,526	68,626	68,727
17	A	59,850	59,938	60,025	60,113	60,200	60,288	60,375	60,463	60,550	60,638	60,725	60,813
	B	68,828	68,928	69,029	69,129	69,230	69,331	69,431	69,532	69,633	69,733	69,834	69,934
18	A	60,900											
	B	70,035											

Computation Formula:  $Weight = 1.5 \times 700 (L + 40)$

(L = Distance between the center of the front axle and the center of the rear axle of a given group.)

Legend:

Line A: 4 Four tires per axle or 2 two 14-inch wide tires. Value is the formula weight only.

Line B: 8 Eight tires per axle or 4 four 14-inch wide tires. Value is the formula weight plus 15%.

**Table 3.02. Maximum Permitted Weight Computations: ~~8-foot, 3-inch~~ Axle Width - 8 Feet 3 Inches**

Overweight Axle Group Chart

Distance between the center of the front axle and the center of the rear axle of a given group.

			Inches											
			0	1	2	3	4	5	6	7	8	9	10	11
Feet	3	A	28,525	28,525	28,525	28,525	28,525	28,525	46,531	46,621	46,710	46,799	46,888	46,977
		B	32,550	32,550	32,550	32,550	32,550	32,550	53,097	53,199	53,301	53,402	53,504	53,606
	4	A	47,066	47,155	47,245	47,334	47,423	47,512	47,601	47,690	47,779	47,869	47,958	48,047
		B	53,708	53,809	53,911	54,013	54,114	54,216	54,318	54,420	54,521	54,623	54,725	54,826
	5	A	48,136	48,225	48,314	48,403	48,493	48,582	48,671	48,760	48,849	48,938	49,027	49,116
		B	54,928	55,030	55,132	55,233	55,335	55,437	55,538	55,640	55,742	55,844	55,945	56,047
	6	A	49,206	49,295	49,384	49,473	49,562	49,651	49,740	49,830	49,919	50,008	50,097	50,186
		B	56,149	56,250	56,352	56,454	56,556	56,657	56,759	56,861	56,963	57,064	57,166	57,268
	7	A	50,275	50,364	50,454	50,543	50,632	50,721	50,810	50,899	50,988	51,078	51,167	51,256
		B	57,369	57,471	57,573	57,675	57,776	57,878	57,980	58,081	58,183	58,285	58,387	58,488
	8	A	51,345	51,434	51,523	51,612	51,702	51,791	51,880	51,969	52,058	52,147	52,236	52,326
		B	58,590	58,692	58,793	58,895	58,997	59,099	59,200	59,302	59,404	59,505	59,607	59,709
	9	A	52,415	52,504	52,593	52,682	52,771	52,860	52,950	53,039	53,128	53,217	53,306	53,395
		B	59,811	59,912	60,014	60,116	60,218	60,319	60,421	60,523	60,624	60,726	60,828	60,930
	10	A	53,484	53,574	53,663	53,752	53,841	53,930	54,019	54,108	54,198	54,287	54,376	54,465
		B	61,031	61,133	61,235	61,336	61,438	61,540	61,642	61,743	61,845	61,947	62,048	62,150
	11	A	54,554	54,643	54,732	54,821	54,911	55,000	55,089	55,178	55,267	55,356	55,445	55,535
		B	62,252	62,354	62,455	62,557	62,659	62,760	62,862	62,964	63,066	63,167	63,269	63,371
	12	A	55,624	55,713	55,802	55,891	55,980	56,069	56,159	56,248	56,337	56,426	56,515	56,604
		B	63,473	63,574	63,676	63,778	63,879	63,981	64,083	64,185	64,286	64,388	64,490	64,591
	13	A	56,693	56,783	56,872	56,961	57,050	57,139	57,228	57,317	57,407	57,496	57,585	57,674
		B	64,693	64,795	64,897	64,998	65,100	65,202	65,303	65,405	65,507	65,609	65,710	65,812

14	A	57,763	57,852	57,941	58,031	58,120	58,209	58,298	58,387	58,476	58,565	58,655	58,744
	B	65,914	66,015	66,117	66,219	66,321	66,422	66,524	66,626	66,728	66,829	66,931	67,033
15	A	58,833	58,922	59,011	59,100	59,189	59,279	59,368	59,457	59,546	59,635	59,724	59,813
	B	67,134	67,236	67,338	67,440	67,541	67,643	67,745	67,846	67,948	68,050	68,152	68,253
16	A	59,903	59,992	60,081	60,170	60,259	60,348	60,437	60,526	60,616	60,705	60,794	60,883
	B	68,355	68,457	68,558	68,660	68,762	68,864	68,965	69,067	69,169	69,270	69,372	69,474
17	A	60,972	61,061	61,150	61,240	61,329	61,418	61,507	61,596	61,685	61,774	61,864	61,953
	B	69,576	69,677	69,779	69,881	69,983	70,084	70,186	70,288	70,389	70,491	70,593	70,695
18	A	62,042											
	B	70,796											

Computation Formula:  $Weight = 1.5 \times 700 (L + 40)$

(L = Distance between the center of the front axle and the center of the rear axle of a given group.)

Legend:

Line A: 4 Four tires per axle or 2) two 14-inch wide tires. Value is the formula weight plus 1.875%.

Line B: 8 Eight tires per axle or 4) four 14-inch wide tires. Value is the formula weight plus 16.25%.

**Table 3.03. Maximum Permitted Weight Computations: ~~8-foot, 6-inch~~ Axle Width - 8 Feet 6 Inches**

Overweight Axle Group Chart

Distance between the center of the front axle and the center of the rear axle of a given group.

			Inches											
			0	1	2	3	4	5	6	7	8	9	10	11
Feet	3	A	29,050	29,050	29,050	29,050	29,050	29,050	47,388	47,479	47,569	47,660	47,751	47,842
		B	32,900	32,900	32,900	32,900	32,900	32,900	53,668	53,771	53,874	53,977	54,079	54,182
	4	A	47,933	48,023	48,114	48,205	48,296	48,386	48,477	48,568	48,659	48,750	48,840	48,931
		B	54,285	54,388	54,491	54,593	54,696	54,799	54,902	55,005	55,108	55,210	55,313	55,416
	5	A	49,022	49,113	49,203	49,294	49,385	49,476	49,567	49,657	49,748	49,839	49,930	50,020
		B	55,519	55,622	55,724	55,827	55,930	56,033	56,136	56,238	56,341	56,444	56,547	56,650
	6	A	50,111	50,202	50,293	50,384	50,474	50,565	50,656	50,747	50,838	50,928	51,019	51,110
		B	56,753	56,855	56,958	57,061	57,164	57,267	57,369	57,472	57,575	57,678	57,781	57,883
	7	A	51,201	51,291	51,382	51,473	51,564	51,655	51,745	51,836	51,927	52,018	52,108	52,199
		B	57,986	58,089	58,192	58,295	58,398	58,500	58,603	58,706	58,809	58,912	59,014	59,117
	8	A	52,290	52,381	52,472	52,562	52,653	52,744	52,835	52,925	53,016	53,107	53,198	53,289
		B	59,220	59,323	59,426	59,528	59,631	59,734	59,837	59,940	60,043	60,145	60,248	60,351
	9	A	53,379	53,470	53,561	53,652	53,743	53,833	53,924	54,015	54,106	54,196	54,287	54,378
		B	60,454	60,557	60,659	60,762	60,865	60,968	61,071	61,173	61,276	61,379	61,482	61,585
	10	A	54,469	54,560	54,650	54,741	54,832	54,923	55,013	55,104	55,195	55,286	55,377	55,467
		B	61,688	61,790	61,893	61,996	62,099	62,202	62,304	62,407	62,510	62,613	62,716	62,818
	11	A	55,558	55,649	55,740	55,830	55,921	56,012	56,103	56,194	56,284	56,375	56,466	56,557
		B	62,921	63,024	63,127	63,230	63,333	63,435	63,538	63,641	63,744	63,847	63,949	64,052
	12	A	56,648	56,738	56,829	56,920	57,011	57,101	57,192	57,283	57,374	57,465	57,555	57,646
		B	64,155	64,258	64,361	64,463	64,566	64,669	64,772	64,875	64,978	65,080	65,183	65,286
	13	A	57,737	57,828	57,918	58,009	58,100	58,191	58,282	58,372	58,463	58,554	58,645	58,735
		B	65,389	65,492	65,594	65,697	65,800	65,903	66,006	66,108	66,211	66,314	66,417	66,520

14	A	58,826	58,917	59,008	59,099	59,189	59,280	59,371	59,462	59,553	59,643	59,734	59,825
	B	66,623	66,725	66,828	66,931	67,034	67,137	67,239	67,342	67,445	67,548	67,651	67,753
15	A	59,916	60,006	60,097	60,188	60,279	60,370	60,460	60,551	60,642	60,733	60,823	60,914
	B	67,856	67,959	68,062	68,165	68,268	68,370	68,473	68,576	68,679	68,782	68,884	68,987
16	A	61,005	61,096	61,187	61,277	61,368	61,459	61,550	61,640	61,731	61,822	61,913	62,004
	B	69,090	69,193	69,296	69,398	69,501	69,604	69,707	69,810	69,913	70,015	70,118	70,221
17	A	62,094	62,185	62,276	62,367	62,458	62,548	62,639	62,730	62,821	62,911	63,002	63,093
	B	70,324	70,427	70,529	70,632	70,735	70,838	70,941	71,043	71,146	71,249	71,352	71,455
18	A	63,184											
	B	71,558											

Computation Formula:  $Weight = 1.5 \times 700 (L + 40)$

(L = Distance between the center of the front axle and the center of the rear axle of a given group.)

Legend:

Line A: 4 Four tires per axle or 2) two 14-inch wide tires. Value is the formula weight plus 3.75%.

Line B: 8 Eight tires per axle or 4) four 14-inch wide tires. Value is the formula weight plus 17.5%.

**Table 3.04. Maximum Permitted Weight Computations: ~~8-foot, 9-inch~~ Axle Width - 8 Feet 9 Inches**

Overweight Axle Group Chart

Distance between the center of the front axle and the center of the rear axle of a given group.

			Inches												
			0	1	2	3	4	5	6	7	8	9	10	11	
Feet	3	A	29,575	29,575	29,575	29,575	29,575	29,575	29,575	48,244	48,337	48,429	48,521	48,614	48,706
		B	33,250	33,250	33,250	33,250	33,250	33,250	33,250	54,239	54,343	54,447	54,551	54,655	54,759
	4	A	48,799	48,891	48,984	49,076	49,168	49,261	49,353	49,446	49,538	49,631	49,723	49,815	
		B	54,863	54,966	55,070	55,174	55,278	55,382	55,486	55,590	55,694	55,798	55,902	56,005	
	5	A	49,908	50,000	50,093	50,185	50,278	50,370	50,462	50,555	50,647	50,740	50,832	50,924	
		B	56,109	56,213	56,317	56,421	56,525	56,629	56,733	56,837	56,941	57,045	57,148	57,252	
	6	A	51,017	51,109	51,202	51,294	51,387	51,479	51,571	51,664	51,756	51,849	51,941	52,034	
		B	57,356	57,460	57,564	57,668	57,772	57,876	57,980	58,084	58,188	58,291	58,395	58,499	
	7	A	52,126	52,218	52,311	52,403	52,496	52,588	52,680	52,773	52,865	52,958	53,050	53,143	
		B	58,603	58,707	58,811	58,915	59,019	59,123	59,227	59,330	59,434	59,538	59,642	59,746	
	8	A	53,235	53,327	53,420	53,512	53,605	53,697	53,790	53,882	53,974	54,067	54,159	54,252	
		B	59,850	59,954	60,058	60,162	60,266	60,370	60,473	60,577	60,681	60,785	60,889	60,993	
	9	A	54,344	54,436	54,529	54,621	54,714	54,806	54,899	54,991	55,083	55,176	55,268	55,361	
		B	61,097	61,201	61,305	61,409	61,513	61,616	61,720	61,824	61,928	62,032	62,136	62,240	
	10	A	55,453	55,546	55,638	55,730	55,823	55,915	56,008	56,100	56,193	56,285	56,377	56,470	
		B	62,344	62,448	62,552	62,655	62,759	62,863	62,967	63,071	63,175	63,279	63,383	63,487	
	11	A	56,562	56,655	56,747	56,839	56,932	57,024	57,117	57,209	57,302	57,394	57,486	57,579	
		B	63,591	63,695	63,798	63,902	64,006	64,110	64,214	64,318	64,422	64,526	64,630	64,734	
	12	A	57,671	57,764	57,856	57,949	58,041	58,133	58,226	58,318	58,411	58,503	58,595	58,688	
		B	64,838	64,941	65,045	65,149	65,253	65,357	65,461	65,565	65,669	65,773	65,877	65,980	
	13	A	58,780	58,873	58,965	59,058	59,150	59,242	59,335	59,427	59,520	59,612	59,705	59,797	
		B	66,084	66,188	66,292	66,396	66,500	66,604	66,708	66,812	66,916	67,020	67,123	67,227	

14	A	59,889	59,982	60,074	60,167	60,259	60,351	60,444	60,536	60,629	60,721	60,814	60,906
	B	67,331	67,435	67,539	67,643	67,747	67,851	67,955	68,059	68,163	68,266	68,370	68,474
15	A	60,998	61,091	61,183	61,276	61,368	61,461	61,553	61,645	61,738	61,830	61,923	62,015
	B	68,578	68,682	68,786	68,890	68,994	69,098	69,202	69,305	69,409	69,513	69,617	69,721
16	A	62,108	62,200	62,292	62,385	62,477	62,570	62,662	62,754	62,847	62,939	63,032	63,124
	B	69,825	69,929	70,033	70,137	70,241	70,345	70,448	70,552	70,656	70,760	70,864	70,968
17	A	63,217	63,309	63,401	63,494	63,586	63,679	63,771	63,864	63,956	64,048	64,141	64,233
	B	71,072	71,176	71,280	71,384	71,488	71,591	71,695	71,799	71,903	72,007	72,111	72,215
18	A	64,326											
	B	72,319											

Computation Formula:  $Weight = 1.5 \times 700 (L + 40)$

(L = Distance between the center of the front axle and the center of the rear axle of a given group.)

Legend:

Line A: 4 Four tires per axle or 2) two 14-inch wide tires. Value is the formula weight plus 5.625%.

Line B: 8 Eight tires per axle or 4) four 14-inch wide tires. Value is the formula weight plus 18.75%.

**Table 3.05. Maximum Permitted Weight Computations: ~~9-foot, 0-inch~~ Axle Width - 9 Feet**

Overweight Axle Group Chart

Distance between the center of the front axle and the center of the rear axle of a given group.

			Inches											
			0	1	2	3	4	5	6	7	8	9	10	11
Feet	3	A	30,100	30,100	30,100	30,100	30,100	30,100	49,101	49,195	49,289	49,383	49,477	49,571
		B	33,600	33,600	33,600	33,600	33,600	33,600	54,810	54,915	55,020	55,125	55,230	55,335
	4	A	49,665	49,759	49,853	49,947	50,041	50,135	50,229	50,323	50,418	50,512	50,606	50,700
		B	55,440	55,545	55,650	55,755	55,860	55,965	56,070	56,175	56,280	56,385	56,490	56,595
	5	A	50,794	50,888	50,982	51,076	51,170	51,264	51,358	51,452	51,546	51,640	51,734	51,828
		B	56,700	56,805	56,910	57,015	57,120	57,225	57,330	57,435	57,540	57,645	57,750	57,855
	6	A	51,923	52,017	52,111	52,205	52,299	52,393	52,487	52,581	52,675	52,769	52,863	52,957
		B	57,960	58,065	58,170	58,275	58,380	58,485	58,590	58,695	58,800	58,905	59,010	59,115
	7	A	53,051	53,145	53,239	53,333	53,428	53,522	53,616	53,710	53,804	53,898	53,992	54,086
		B	59,220	59,325	59,430	59,535	59,640	59,745	59,850	59,955	60,060	60,165	60,270	60,375
	8	A	54,180	54,274	54,368	54,462	54,556	54,650	54,744	54,838	54,933	55,027	55,121	55,215
		B	60,480	60,585	60,690	60,795	60,900	61,005	61,110	61,215	61,320	61,425	61,530	61,635
	9	A	55,309	55,403	55,497	55,591	55,685	55,779	55,873	55,967	56,061	56,155	56,249	56,343
		B	61,740	61,845	61,950	62,055	62,160	62,265	62,370	62,475	62,580	62,685	62,790	62,895
	10	A	56,438	56,532	56,626	56,720	56,814	56,908	57,002	57,096	57,190	57,284	57,378	57,472
		B	63,000	63,105	63,210	63,315	63,420	63,525	63,630	63,735	63,840	63,945	64,050	64,155
	11	A	57,566	57,660	57,754	57,848	57,943	58,037	58,131	58,225	58,319	58,413	58,507	58,601
		B	64,260	64,365	64,470	64,575	64,680	64,785	64,890	64,995	65,100	65,205	65,310	65,415
	12	A	58,695	58,789	58,883	58,977	59,071	59,165	59,259	59,353	59,448	59,542	59,636	59,730
		B	65,520	65,625	65,730	65,835	65,940	66,045	66,150	66,255	66,360	66,465	66,570	66,675
	13	A	59,824	59,918	60,012	60,106	60,200	60,294	60,388	60,482	60,576	60,670	60,764	60,858
		B	66,780	66,885	66,990	67,095	67,200	67,305	67,410	67,515	67,620	67,725	67,830	67,935

14	A	60,953	61,047	61,141	61,235	61,329	61,423	61,517	61,611	61,705	61,799	61,893	61,987
	B	68,040	68,145	68,250	68,355	68,460	68,565	68,670	68,775	68,880	68,985	69,090	69,195
15	A	62,081	62,175	62,269	62,363	62,458	62,552	62,646	62,740	62,834	62,928	63,022	63,116
	B	69,300	69,405	69,510	69,615	69,720	69,825	69,930	70,035	70,140	70,245	70,350	70,455
16	A	63,210	63,304	63,398	63,492	63,586	63,680	63,774	63,868	63,963	64,057	64,151	64,245
	B	70,560	70,665	70,770	70,875	70,980	71,085	71,190	71,295	71,400	71,505	71,610	71,715
17	A	64,339	64,433	64,527	64,621	64,715	64,809	64,903	64,997	65,091	65,185	65,279	65,373
	B	71,820	71,925	72,030	72,135	72,240	72,345	72,450	72,555	72,660	72,765	72,870	72,975
18	A	65,468											
	B	73,080											

Computation Formula:  $Weight = 1.5 \times 700 (L + 40)$

(L = Distance between the center of the front axle and the center of the rear axle of a given group.)

Legend:

Line A: 4 Four tires per axle or 2) two 14-inch wide tires. Value is the formula weight plus 7.5%.

Line B: 8 Eight tires per axle or 4) four 14-inch wide tires. Value is the formula weight plus 20%.

**Table 3.06. Maximum Permitted Weight Computations: ~~9-foot, 3-inch~~ Axle Width - 9 Feet 3 Inches**

Overweight Axle Group Chart

Distance between the center of the front axle and the center of the rear axle of a given group.

			Inches											
			0	1	2	3	4	5	6	7	8	9	10	11
Feet	3	A	30,625	30,625	30,625	30,625	30,625	30,625	49,957	50,053	50,148	50,244	50,340	50,436
		B	33,950	33,950	33,950	33,950	33,950	33,950	55,381	55,487	55,593	55,699	55,805	55,911
	4	A	50,531	50,627	50,723	50,818	50,914	51,010	51,105	51,201	51,297	51,393	51,488	51,584
		B	56,018	56,124	56,230	56,336	56,442	56,548	56,654	56,760	56,866	56,972	57,078	57,185
	5	A	51,680	51,775	51,871	51,967	52,063	52,158	52,254	52,350	52,445	52,541	52,637	52,732
		B	57,291	57,397	57,503	57,609	57,715	57,821	57,927	58,033	58,139	58,245	58,352	58,458
	6	A	52,828	52,924	53,020	53,115	53,211	53,307	53,402	53,498	53,594	53,689	53,785	53,881
		B	58,564	58,670	58,776	58,882	58,988	59,094	59,200	59,306	59,413	59,519	59,625	59,731
	7	A	53,977	54,072	54,168	54,264	54,359	54,455	54,551	54,646	54,742	54,838	54,934	55,029
		B	59,837	59,943	60,049	60,155	60,261	60,367	60,473	60,580	60,686	60,792	60,898	61,004
	8	A	55,125	55,221	55,316	55,412	55,508	55,604	55,699	55,795	55,891	55,986	56,082	56,178
		B	61,110	61,216	61,322	61,428	61,534	61,640	61,747	61,853	61,959	62,065	62,171	62,277
	9	A	56,273	56,369	56,465	56,561	56,656	56,752	56,848	56,943	57,039	57,135	57,230	57,326
		B	62,383	62,489	62,595	62,701	62,808	62,914	63,020	63,126	63,232	63,338	63,444	63,550
	10	A	57,422	57,518	57,613	57,709	57,805	57,900	57,996	58,092	58,188	58,283	58,379	58,475
		B	63,656	63,762	63,868	63,975	64,081	64,187	64,293	64,399	64,505	64,611	64,717	64,823
	11	A	58,570	58,666	58,762	58,857	58,953	59,049	59,145	59,240	59,336	59,432	59,527	59,623
		B	64,929	65,035	65,142	65,248	65,354	65,460	65,566	65,672	65,778	65,884	65,990	66,096
	12	A	59,719	59,814	59,910	60,006	60,102	60,197	60,293	60,389	60,484	60,580	60,676	60,771
		B	66,203	66,309	66,415	66,521	66,627	66,733	66,839	66,945	67,051	67,157	67,263	67,370
	13	A	60,867	60,963	61,059	61,154	61,250	61,346	61,441	61,537	61,633	61,729	61,824	61,920
		B	67,476	67,582	67,688	67,794	67,900	68,006	68,112	68,218	68,324	68,430	68,537	68,643

14	A	62,016	62,111	62,207	62,303	62,398	62,494	62,590	62,686	62,781	62,877	62,973	63,068
	B	68,749	68,855	68,961	69,067	69,173	69,279	69,385	69,491	69,598	69,704	69,810	69,916
15	A	63,164	63,260	63,355	63,451	63,547	63,643	63,738	63,834	63,930	64,025	64,121	64,217
	B	70,022	70,128	70,234	70,340	70,446	70,552	70,658	70,765	70,871	70,977	71,083	71,189
16	A	64,313	64,408	64,504	64,600	64,695	64,791	64,887	64,982	65,078	65,174	65,270	65,365
	B	71,295	71,401	71,507	71,613	71,719	71,825	71,932	72,038	72,144	72,250	72,356	72,462
17	A	65,461	65,557	65,652	65,748	65,844	65,939	66,035	66,131	66,227	66,322	66,418	66,514
	B	72,568	72,674	72,780	72,886	72,993	73,099	73,205	73,311	73,417	73,523	73,629	73,735
18	A	66,609											
	B	73,841											

Computation Formula:  $Weight = 1.5 \times 700 (L + 40)$

(L = Distance between the center of the front axle and the center of the rear axle of a given group.)

Legend:

Line A: 4 Four tires per axle or 2) two 14-inch wide tires. Value is the formula weight plus 9.375%.

Line B: 8 Eight tires per axle or 4) four 14-inch wide tires. Value is the formula weight plus 21.25%.

**Table 3.07. Maximum Permitted Weight Computations: ~~9-foot, 6-inch~~ Axle Width - 9 Feet 6 Inches**

Overweight Axle Group Chart

Distance between the center of the front axle and the center of the rear axle of a given group.

			Inches											
			0	1	2	3	4	5	6	7	8	9	10	11
Feet	3	A	31,150	31,150	31,150	31,150	31,150	31,150	50,813	50,911	51,008	51,105	51,203	51,300
		B	34,300	34,000	34,300	34,300	34,300	34,300	55,952	56,059	56,166	56,273	56,381	56,488
	4	A	51,398	51,495	51,592	51,690	51,787	51,884	51,982	52,079	52,176	52,274	52,371	52,468
		B	56,595	56,702	56,809	56,917	57,024	57,131	57,238	57,345	57,453	57,560	57,667	57,774
	5	A	52,566	52,663	52,760	52,858	52,955	53,052	53,150	53,247	53,344	53,442	53,539	53,636
		B	57,881	57,988	58,096	58,203	58,310	58,417	58,524	58,632	58,739	58,846	58,953	59,060
	6	A	53,734	53,831	53,928	54,026	54,123	54,220	54,318	54,415	54,513	54,610	54,707	54,805
		B	59,168	59,275	59,382	59,489	59,596	59,703	59,811	59,918	60,025	60,132	60,239	60,347
	7	A	54,902	54,999	55,097	55,194	55,291	55,389	55,486	55,583	55,681	55,778	55,875	55,973
		B	60,454	60,561	60,668	60,775	60,883	60,990	61,097	61,204	61,311	61,418	61,526	61,633
	8	A	56,070	56,167	56,265	56,362	56,459	56,557	56,654	56,751	56,849	56,946	57,043	57,141
		B	61,740	61,847	61,954	62,062	62,169	62,276	62,383	62,490	62,598	62,705	62,812	62,919
	9	A	57,238	57,335	57,433	57,530	57,628	57,725	57,822	57,920	58,017	58,114	58,212	58,309
		B	63,026	63,133	63,241	63,348	63,455	63,562	63,669	63,777	63,884	63,991	64,098	64,205
	10	A	58,406	58,504	58,601	58,698	58,796	58,893	58,990	59,088	59,185	59,282	59,380	59,477
		B	64,313	64,420	64,527	64,634	64,741	64,848	64,956	65,063	65,170	65,277	65,384	65,492
	11	A	59,574	59,672	59,769	59,866	59,964	60,061	60,158	60,256	60,353	60,450	60,548	60,645
		B	65,599	65,706	65,813	65,920	66,028	66,135	66,242	66,349	66,456	66,563	66,671	66,778
	12	A	60,743	60,840	60,937	61,035	61,132	61,229	61,327	61,424	61,521	61,619	61,716	61,813
		B	66,885	66,992	67,099	67,207	67,314	67,421	67,528	67,635	67,743	67,850	67,957	68,064
	13	A	61,911	62,008	62,105	62,203	62,300	62,397	62,495	62,592	62,689	62,787	62,884	62,981
		B	68,171	68,278	68,386	68,493	68,600	68,707	68,814	68,922	69,029	69,136	69,243	69,350

14	A	63,079	63,176	63,273	63,371	63,468	63,565	63,663	63,760	63,858	63,955	64,052	64,150
	B	69,458	69,565	69,672	69,779	69,886	69,993	70,101	70,208	70,315	70,422	70,529	70,637
15	A	64,247	64,344	64,442	64,539	64,636	64,734	64,831	64,928	65,026	65,123	65,220	65,318
	B	70,744	70,851	70,958	71,065	71,173	71,280	71,387	71,494	71,601	71,708	71,816	71,923
16	A	65,415	65,512	65,610	65,707	65,804	65,902	65,999	66,096	66,194	66,291	66,388	66,486
	B	72,030	72,137	72,244	72,352	72,459	72,566	72,673	72,780	72,888	72,995	73,102	73,209
17	A	66,583	66,680	66,778	66,875	66,973	67,070	67,167	67,265	67,362	67,459	67,557	67,654
	B	73,316	73,423	73,531	73,638	73,745	73,852	73,959	74,067	74,174	74,281	74,388	74,495
18	A	67,751											
	B	74,603											

Computation Formula:  $Weight = 1.5 \times 700 (L + 40)$

(L = Distance between the center of the front axle and the center of the rear axle of a given group.)

Legend:

Line A: 4 Four tires per axle or 2) two 14-inch wide tires. Value is the formula weight plus 11.25%.

Line B: 8 Eight tires per axle or 4) four 14-inch wide tires. Value is the formula weight plus 22.5%.

**Table 3.08. Maximum Permitted Weight Computations: ~~9-foot, 9-inch~~ Axle Width - 9 Feet 9 Inches**

Overweight Axle Group Chart

Distance between the center of the front axle and the center of the rear axle of a given group.

			Inches											
			0	1	2	3	4	5	6	7	8	9	10	11
Feet	3	A	31,675	31,675	31,675	31,675	31,675	31,675	51,670	51,769	51,868	51,967	52,066	52,165
		B	34,650	34,650	34,650	34,650	34,650	34,650	56,523	56,631	56,739	56,848	56,956	57,064
	4	A	52,264	52,363	52,462	52,561	52,660	52,759	52,858	52,957	53,056	53,155	53,254	53,353
		B	57,173	57,281	57,389	57,497	57,606	57,714	57,822	57,930	58,039	58,147	58,255	58,364
	5	A	53,452	53,551	53,650	53,749	53,848	53,946	54,045	54,144	54,243	54,342	54,441	54,540
		B	58,472	58,580	58,688	58,797	58,905	59,013	59,122	59,230	59,338	59,446	59,555	59,663
	6	A	54,639	54,738	54,837	54,936	55,035	55,134	55,233	55,332	55,431	55,530	55,629	55,728
		B	59,771	59,880	59,988	60,096	60,204	60,313	60,421	60,529	60,638	60,746	60,854	60,962
	7	A	55,827	55,926	56,025	56,124	56,223	56,322	56,421	56,520	56,619	56,718	56,817	56,916
		B	61,071	61,179	61,287	61,395	61,504	61,612	61,720	61,829	61,937	62,045	62,153	62,262
	8	A	57,015	57,114	57,213	57,312	57,411	57,510	57,609	57,708	57,807	57,906	58,005	58,104
		B	62,370	62,478	62,587	62,695	62,803	62,911	63,020	63,128	63,236	63,345	63,453	63,561
	9	A	58,203	58,302	58,401	58,500	58,599	58,698	58,797	58,896	58,995	59,094	59,193	59,292
		B	63,669	63,778	63,886	63,994	64,103	64,211	64,319	64,427	64,536	64,644	64,752	64,860
	10	A	59,391	59,490	59,589	59,688	59,787	59,886	59,985	60,084	60,183	60,281	60,380	60,479
		B	64,969	65,077	65,185	65,294	65,402	65,510	65,618	65,727	65,835	65,943	66,052	66,160
	11	A	60,578	60,677	60,776	60,875	60,974	61,073	61,172	61,271	61,370	61,469	61,568	61,667
		B	66,268	66,376	66,485	66,593	66,701	66,810	66,918	67,026	67,134	67,243	67,351	67,459
	12	A	61,766	61,865	61,964	62,063	62,162	62,261	62,360	62,459	62,558	62,657	62,756	62,855
		B	67,568	67,676	67,784	67,892	68,001	68,109	68,217	68,325	68,434	68,542	68,650	68,759
	13	A	62,954	63,053	63,152	63,251	63,350	63,449	63,548	63,647	63,746	63,845	63,944	64,043
		B	68,867	68,975	69,083	69,192	69,300	69,408	69,517	69,625	69,733	69,841	69,950	70,058

14	A	64,142	64,241	64,340	64,439	64,538	64,637	64,736	64,835	64,934	65,033	65,132	65,231
	B	70,166	70,275	70,383	70,491	70,599	70,708	70,816	70,924	71,033	71,141	71,249	71,357
15	A	65,330	65,429	65,528	65,627	65,726	65,825	65,924	66,023	66,122	66,221	66,320	66,419
	B	71,466	71,574	71,682	71,790	71,899	72,007	72,115	72,224	72,332	72,440	72,548	72,657
16	A	66,518	66,616	66,715	66,814	66,913	67,012	67,111	67,210	67,309	67,408	67,507	67,606
	B	72,765	72,873	72,982	73,090	73,198	73,306	73,415	73,523	73,631	73,740	73,848	73,956
17	A	67,705	67,804	67,903	68,002	68,101	68,200	68,299	68,398	68,497	68,596	68,695	68,794
	B	74,064	74,173	74,281	74,389	74,498	74,606	74,714	74,822	74,931	75,039	75,147	75,255
18	A	68,893											
	B	75,364											

Computation Formula:  $Weight = 1.5 \times 700 (L + 40)$

(L = Distance between the center of the front axle and the center of the rear axle of a given group.)

Legend:

Line A: 4 Four tires per axle or 2) two 14-inch wide tires. Value is the formula weight plus 13.125%.

Line B: 8 Eight tires per axle or 4) four 14-inch wide tires. Value is the formula weight plus 23.75%.

**Table 3.09. Maximum Permitted Weight Computations: ~~10-foot, 0-inch~~ Axle Width - 10 Feet**

Overweight Axle Group Chart

Distance between the center of the front axle and the center of the rear axle of a given group.

			Inches											
			0	1	2	3	4	5	6	7	8	9	10	11
Feet	3	A	32,200	32,200	32,200	32,200	32,200	32,200	52,526	52,627	52,728	52,828	52,929	53,029
		B	35,000	35,000	35,000	35,000	35,000	35,000	57,094	57,203	57,313	57,422	57,531	57,641
	4	A	53,130	53,231	53,331	53,432	53,533	53,633	53,734	53,834	53,935	54,036	54,136	54,237
		B	57,750	57,859	57,969	58,078	58,188	58,297	58,406	58,516	58,625	58,734	58,844	58,953
	5	A	54,338	54,438	54,539	54,639	54,740	54,841	54,941	55,042	55,143	55,243	55,344	55,444
		B	59,063	59,172	59,281	59,391	59,500	59,609	59,719	59,828	59,938	60,047	60,156	60,266
	6	A	55,545	55,646	55,746	55,847	55,948	56,048	56,149	56,249	56,350	56,451	56,551	56,652
		B	60,375	60,484	60,594	60,703	60,813	60,922	61,031	61,141	61,250	61,359	61,469	61,578
	7	A	56,753	56,853	56,954	57,054	57,155	57,256	57,356	57,457	57,558	57,658	57,759	57,859
		B	61,688	61,797	61,906	62,016	62,125	62,234	62,344	62,453	62,563	62,672	62,781	62,891
	8	A	57,960	58,061	58,161	58,262	58,363	58,463	58,564	58,664	58,765	58,866	58,966	59,067
		B	63,000	63,109	63,219	63,328	63,438	63,547	63,656	63,766	63,875	63,984	64,094	64,203
	9	A	59,168	59,268	59,369	59,469	59,570	59,671	59,771	59,872	59,973	60,073	60,174	60,274
		B	64,313	64,422	64,531	64,641	64,750	64,859	64,969	65,078	65,188	65,297	65,406	65,516
	10	A	60,375	60,476	60,576	60,677	60,778	60,878	60,979	61,079	61,180	61,281	61,381	61,482
		B	65,625	65,734	65,844	65,953	66,063	66,172	66,281	66,391	66,500	66,609	66,719	66,828
	11	A	61,583	61,683	61,784	61,884	61,985	62,086	62,186	62,287	62,388	62,488	62,589	62,689
		B	66,938	67,047	67,156	67,266	67,375	67,484	67,594	67,703	67,813	67,922	68,031	68,141
	12	A	62,790	62,891	62,991	63,092	63,193	63,293	63,394	63,494	63,595	63,696	63,796	63,897
		B	68,250	68,359	68,469	68,578	68,688	68,797	68,906	69,016	69,125	69,234	69,344	69,453
	13	A	63,998	64,098	64,199	64,299	64,400	64,501	64,601	64,702	64,803	64,903	65,004	65,104
		B	69,563	69,672	69,781	69,891	70,000	70,109	70,219	70,328	70,438	70,547	70,656	70,766

14	A	65,205	65,306	65,406	65,507	65,608	65,708	65,809	65,909	66,010	66,111	66,211	66,312
	B	70,875	70,984	71,094	71,203	71,313	71,422	71,531	71,641	71,750	71,859	71,969	72,078
15	A	66,413	66,513	66,614	66,714	66,815	66,916	67,016	67,117	67,218	67,318	67,419	67,519
	B	72,188	72,297	72,406	72,516	72,625	72,734	72,844	72,953	73,063	73,172	73,281	73,391
16	A	67,620	67,721	67,821	67,922	68,023	68,123	68,224	68,324	68,425	68,526	68,626	68,727
	B	73,500	73,609	73,719	73,828	73,938	74,047	74,156	74,266	74,375	74,484	74,594	74,703
17	A	68,828	68,928	69,029	69,129	69,230	69,331	69,431	69,532	69,633	69,733	69,834	69,934
	B	74,813	74,922	75,031	75,141	75,250	75,359	75,469	75,578	75,688	75,797	75,906	76,016
18	A	70,035											
	B	76,125											

Computation Formula:  $Weight = 1.5 \times 700 (L + 40)$

(L = Distance between the center of the front axle and the center of the rear axle of a given group.)

Legend:

Line A: 4 Four tires per axle or 2) two 14-inch wide tires. Value is the formula weight plus 15%.

Line B: 8 Eight tires per axle or 4) four 14-inch wide tires. Value is the formula weight plus 25%.

**Illustration 3. Overweight Axle Groups**

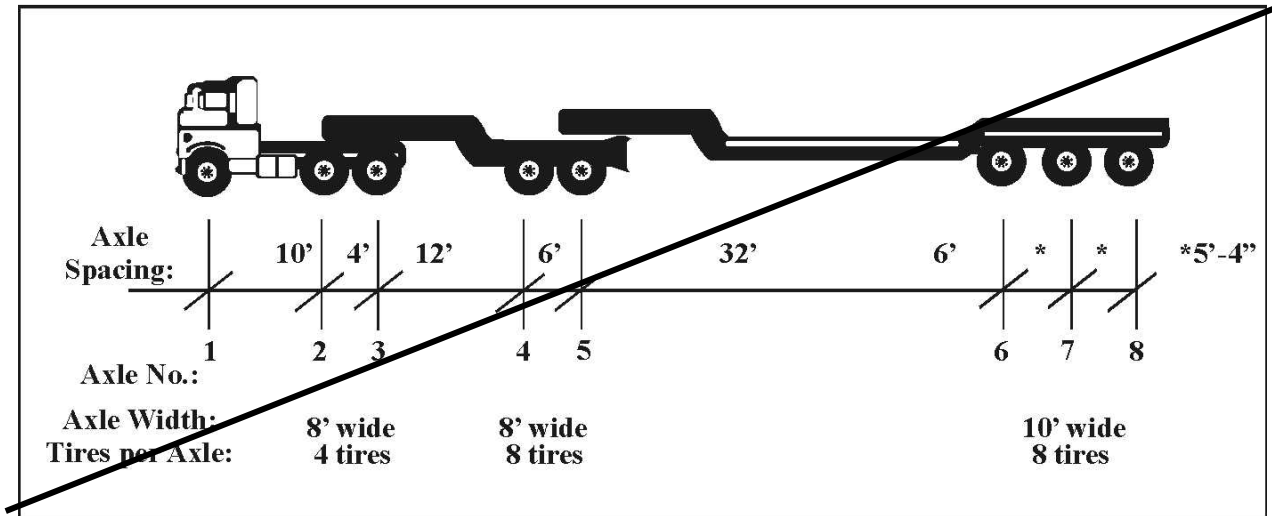

The axle group weights shown on the previous tables are maximum weights allowed on any combination of axles within the distance between the front and rear axle of a given group up to a maximum of 18 feet. The values in Table 3.01 line "A" are an expansion of the formula  $W = 1.5 \times 700 (L + 40)$ , where L is the distance between the centers of the front and rear axles of a group. The values in line "B" and in the remaining tables are computed by applying the percentages prescribed in the tables' footnotes and are intended to increase the allowable weights based on wider axles and increased number of tires. Measured axle widths shall be rounded down to the nearest one fourth foot when determining the appropriate table to use.

Note:—The Department shall review each possible axle group that can exist within an 18-foot distance. Axles of different configurations of width or number of tires shall be prorated within the total group load in determining any allowed increase over the basic formula weight.

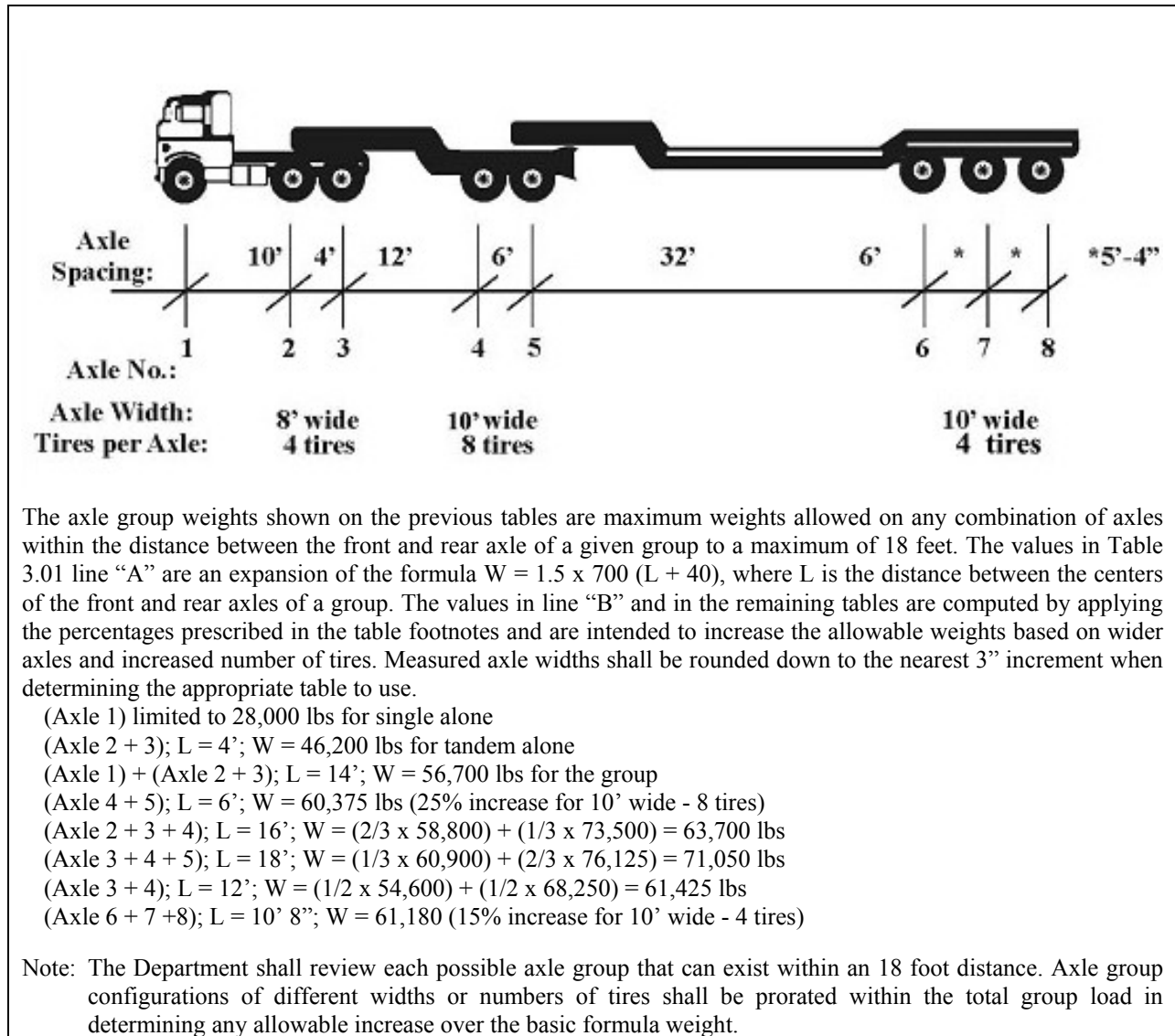

**R17-6-412. Highway-specific ~~Overdimensional Permitted Vehicle~~ Restrictions, Requirements, Conditions, and Allowances - Oversize and Overweight**

**A.** Highway-use restrictions on transport by ~~overdimensional~~ oversize and overweight special permitted vehicles apply as follows:

1. Permanent highway restrictions. A permittee or driver of an ~~overdimensional~~ oversize or overweight vehicle or load shall not access ~~routes in Table 4~~ a route listed under R17-6-412, Table 4, unless operating in full compliance with all indicated restrictions, requirements, conditions, and allowances.
2. Temporary highway restrictions. The Department may temporarily ~~restrict highway access to overdimensional permit transport for no more than 12 months, due to a construction or maintenance project~~ prohibit operation of oversize or overweight special permitted vehicles, or temporarily impose additional weight restrictions, requirements, conditions, or allowances on overweight special permitted vehicles if

safe transport on a highway under the Department's jurisdiction is unavoidably affected by a temporary construction or maintenance project, incident, or emergency situation. A permittee or driver shall check daily for changes in temporary highway restrictions by:

- a. ~~In electronic format at internet address: [www.az511.com](http://www.az511.com), and selecting "Closures and Restrictions;"~~ Accessing the Department's Traffic Operations Center online for up-to-date information on traffic conditions, road closures, and restrictions at [www.az511.gov](http://www.az511.gov); or
- b. ~~By direct telephone communication with a highway project engineer in an ADOT district office in oversight of a permittee's applicable transport route as follows:~~
  - i. ~~Flagstaff: (928) 779-7547;~~
  - ii. ~~Globe: (928) 425-7638;~~
  - iii. ~~Holbrook: (928) 524-6801;~~
  - iv. ~~Kingman: (928) 681-6010;~~
  - v. ~~Phoenix: For the Phoenix metropolitan area, a permittee shall check with both the Phoenix Construction and Maintenance districts:~~
    - (1) ~~Phoenix Maintenance: (602) 712-6664; or~~
    - (2) ~~Phoenix Construction: (602) 712-8965;~~
  - vi. ~~Prescott: (928) 777-5860;~~
  - vii. ~~Safford: (928) 428-5470;~~
  - viii. ~~Tucson: (520) 620-5412; or~~
  - ix. ~~Yuma: (928) 317-2100.~~
- b. Contacting a highway project engineer at the ADOT district office responsible for oversight of the permittee's applicable transport route as published on the Department's web site at [www.azdot.gov/Highways](http://www.azdot.gov/Highways).

**B.** Electronic special permit application and issuance through the Department's electronic service provider is not available for any route where the vehicle and load combination exceeds any restriction listed under Table 4.

**Table 4. Permanent ~~Overdimensional~~ Vehicle Highway Restrictions, Requirements, Conditions, and Allowances**

MP—Milepost	Jet—Junction of Routes	F/R—Escorts at Front and Rear					
Route Type	Route #	Restriction Criteria	Special Move-ment	Maximum Height	Maximum Length	At or over a width of	Maximum Weight (in lbs)
Interstate	8	All of route	See R17-6-405, R17-6-409				
Interstate	10	All of route	See R17-6-405, R17-6-409				
Interstate	10	MP 205.45 (Battaglia underpass)		15' 9"			

Interstate	10	Eastbound at MP 289.35 (Pantano Railroad underpass)		15'			
Interstate	10	Westbound at MP 289.35 (Pantano Railroad underpass)		15' 3"			
Interstate Business	10	MP 305.79 (SR 80 underpass)		14'			
Interstate Business	10	MP 305.85 (SP Railroad underpass)		14' 3"			
Interstate	15	All of route	See R17-6-405, R17-6-409				
Interstate	15	LCVs only - All of route requires Class E (See R17-6-206, Table 2)			92'		111,000
Interstate	15	LCVs only - All of route requires Class E (See R17-6-206, Table 2)			105'		129,000
Interstate	17	All of route	See R17-6-405, R17-6-409				
Interstate	17	Southbound at MP 293.26 (Cornville/McGuireville underpass)		14' 11"			
Interstate	17	19th Avenue to Buckeye Road		15' 8"			
Interstate	19	All of route	See R17-6-405, R17-6-409				
Interstate	40	All of route	See R17-6-405, R17-6-409				
Interstate Business	40	Jet I 40 (West Flagstaff Traffic Interchange) to Jet US 89				12' requires F/R	
Interstate Business	40	MP 142.18 (Seligman GS)		15' 3"			
Interstate Business	40	MP 142.21 (SF Railroad underpass)		15' 3"			
Interstate Business	40	MP 165.98 (ATSE Railroad underpass)		14' 10"			

Interstate Business	40	MP 195.96 (SP Railroad underpass)		13' 9"			
State	51	All of route	See R17-6-405, R17-6-409				
US	60	Wickenburg to Florence Junction	See R17-6-405, R17-6-409				
US	60	Florence Junction to Globe			80'+ unarticulated vehicle requires F/R; 110'+ articulated vehicle requires F/R	11' requires F/R	
US	60	MP 228.13 (Queen Creek Tunnel)		14'			
US	60	Salt River Canyon to Show Low			80'+ unarticulated vehicle requires F/R; 110'+ articulated vehicle requires F/R	12' requires F/R	
US	60	Jet SR 61 to Jet US 180				12' requires F/R	
US	60	Eastbound at MP 110.24 (Wickenburg Railroad underpass)		13' 11"			
US	60	Westbound at MP 110.24 (Frontier Street underpass)		13' 7"			
US	61	Jet US 60 to Jet US 180				12' requires F/R	
State	61	Jet US 191 to State Line				10' requires F/R	
State	64	MP 237.1 to Jet US 89				12' requires F/R	
US	64	MP 470 to MP 465.2 requires Class E (See R17-6-206, Table 2)			92'		123,500
State	67	MP 579.36 to North Rim (Seasonal restriction Nov. 15 through May 15)					20,000

State	67	Jet US 89A to North Rim				12' requires F/R	
State	68	Jet US 93 to Jet SR 95	See R17-6-405, R17-6-409				
State	69	Jet I 17 to Prescott	See R17-6-405, R17-6-409				
US	70	MP 253.63 (Pinal SP Railroad)		15' 8"			
State	71	Jet US 60 to Jet State 89				12' requires F/R	
State	72	Jet SR 95 to Jet US 60				12' requires F/R	
State	73	Jet US 60 to MP 334.72				10' requires F/R	
State	77	MP 109.15 (San Manuel overpass)		14'			
State	77	MP 119.15 (San Manuel overpass)		14' 1"			
State	77	Winkelman to Jet US 70			80'+ unarticulated vehicle requires F/R; 110'+ articulated vehicle requires F/R	12' requires F/R	
State	77	Show Low to Holbrook				12' requires F/R	
State	78	Jet SR 75 and US 191 to state line				12' requires F/R	
State	80	MP 317.65 (Tombstone pedestrian underpass)		15' 2"			
State	80	MP 343.57 (Lowell underpass)		12' 11"			
State	80	Douglas to New Mexico State Line				12' requires F/R	
State	82	Sonoita to Jet SR 80				12' requires F/R	
State	83	MP 3.19 to Sonoita				10' requires F/R	

State	83	Sonoita to Jet I 10				12' requires F/R	
State	84	MP 177.67 (SP Railroad underpass)		44'			
State	85	International boundary to Ajo				12' requires F/R	
State	85	MP 0.38 (SP railroad underpass)		44' 8"			
State	85	MP 0.57 (I-8 westbound overpass)		45'			
State	85	MP 0.58 (I-8 eastbound overpass)		45'			
State	85	MP 120.41 (Interstate Business 8 underpass—detour available)		45' 6"			
State	86	Why (Jet SR 85) to Jet SR 286 (Coordinate with Tohono O'odham Police)				12' requires F/R	
State	87	Jet US 60 to Payson	See R17-6-405, R17-6-409				
State	87	MP 254 (Payson) to Winslow				12' requires F/R	
State	88	Idaho Road to MP 242.04 (Roosevelt)				Over 8' requires class C permit	
State	88	MP 220.6 to MP 226.6			40'		20,000
State	88	MP 209.5 (Willow Creek Bridge)		44'			
State	88	MP 222 to MP 224.3 ONE LANE ROAD RESTRICTION					
State	89	Jet US 93 to Prescott City limits				12' requires F/R	
State	89	MP 295 to MP 308			40'	Over 8' requires class C permit	

US	89	MP 549-54, Glen Canyon Bridge (Requires that vehicle come to complete stop, then proceed at 5 m.p.h. with no gear shifting)					150,000	
US	89	MP 552 to MP 532, LCVs require Class E (See R17-6-206, Table 2)			92'		111,000	
State	89A	Jet State 89 (Prescott) to MP 331				12' requires F/R		
State	89A	MP 319.01 (Santa Fe Railroad underpass)		13' 11"				
State	89A	MP 331 to MP 346			50'	Over 8' requires class C permit		
State	89A	Jet SR 179 (Sedona) to Flagstaff				10' requires F/R		
US	89A	Jet US 89 to MP 548 (Cliffdweller's Lodge)				10' requires F/R		
US	89A	MP 548 to Jacob Lake				Over 8' 6" requires class C permit		
US	89A	Jacob Lake to Fredonia				12' requires F/R		
US	89A	MP 610 to MP 579.4, LCVs require Class E (See R17-3-206, Table 2)			92'		123,500	
State	90	Jet I 10 to Sierra Vista	See R17-6-405, R17-6-409					
US	93	<b>Post marker 3 to Hoover Dam</b> — No overdimensional vehicle permitted						
US	93	MP 17 to MP 3				10' requires F/R		
US	93	Jet I 40 to Jet SR 68	See R17-6-405, R17-6-409					
US	93	Wikieup to Jet SR 97				12' requires F/R		
State	95	Jet SR 68 to city limits of Bullhead City	See R17-6-405, R17-6-409					

State Spur	95	MP 144.83 (Colorado River Bridge)					80,000
State	96	Jet SR 97 to Hillside				10 <sup>2</sup> requires F/R	
State	98	Jet US 89 to MP 320, LCVs require Class E (see R17-6-206, Table 2)			92 <sup>2</sup>		111,000
State	98	MP 361.39 (electrical wire near Jet US 160)		16 <sup>2</sup> 6 <sup>2</sup>			
State	101	All of route	See R17-6-405, R17-6-409				
State	160	MP 470 to MP 394, LCVs require Class E (see R17-6-206, Table 2)			92 <sup>2</sup>		123,500
US	163	Jet US 160 (Kayenta) to State Line				12 <sup>2</sup> requires F/R	
US	163	MP 410 to MP 394.5, requires Class E (See R17-6-206, Table 2)			92 <sup>2</sup>		123,500
State	170	Jet US 70 to Route End				12 <sup>2</sup> requires F/R	
State	177	Winkelman to Jet US 60 (Superior)				12 <sup>2</sup> requires F/R	
State	179	Jet I 17 to Sedona				12 <sup>2</sup> requires F/R	
US	180	Jet SR 64 to Flagstaff				12 <sup>2</sup> requires F/R	
US	180	Jet US 60 (Springerville) to Jet US 191 (Alpine)				12 <sup>2</sup> requires F/R	
US	180	Jet SR 77 to Jet SR 61				12 <sup>2</sup> requires F/R	
State	181	Jet US 191 to MP 65.04 (Chiricahua Nat'l Monument)				12 <sup>2</sup> requires F/R	
State	186	Dos Cabezas (MP 342.92) to Jet SR 181				10 <sup>2</sup> requires F/R	
State	187	Jet 387 to Jet SR 87				12 <sup>2</sup> requires F/R	

State	188	MP 250 to MP 260				12' requires F/R	
US	191	Jet I 40 to Jet US 160				12' requires F/R	
US	191	MP 173.18 to Jet US 180 (Alpine)			40'	Over 8' requires class C permit	
State	202	All of route	See R17-6-405, R17-6-409				
State	260	Jet SR 87 (Payson) to Star Valley	See R17-6-405, R17-6-409				
State	260	Jet SR 87 (Payson) to MP 339				12' requires F/R	
State	260	MP 358 to MP 410			80'+ requires F/R	12' requires F/R	
State	261	MP 394.4 to 412.7					35,000
State	264	Jet US 160 to MP 471.29				12' requires F/R	
State	266	Jet US 191 to MP 123.8				12' requires F/R	
State	273	All of route			80'+ requires F/R	10' requires F/R	20,000
State	286	International boundary to Jet SR 86				12' requires F/R	
State	288	Jet SR 188 to Route End (Near Young)			70'	Over 8' requires class C permit	
State	288	MP 262.44 (Salt River Bridge)		12'			80,000
State	289	Jet I 19 to Route End				10' requires F/R	
State	347	Jet SR 84 to Jet I 10	See R17-6-405, R17-6-409				
State	366	MP 115 to Route End (Graham Peak)			40'	Over 8' requires class C permit	

**ODPC Final Draft -  
(10/21/2011)**

Not yet approved or proposed

State	377	Jet SR 277 to Jet SR 77				12' requires F/R	
State	386	Jet SR 86 to Kitt Peak				10' requires F/R	
State	389	<del>LCVs only</del> All of route requires Class E (See R17-6-206, Table 2)			92'		123,500
State	473	Jet SR 260 to Route End (Hawley Lake)			60'+ requires F/R	10' requires F/R	20,000
State	564	Jet US 160 to Route End				12' requires F/R	

**ODPC Final Draft -  
(10/21/2011)**  
Not yet approved or proposed

Route	Restriction Location (MP = Mile Post)	Movement Subject to:	Height	Length	Width	Weight (in lbs)
<b>Escort requirements: F = front escort, R = rear escort, F/R = front and rear escort, and LE = law enforcement escort</b>						
Interstate 8	MP 0.00 (California State Line) to MP 144.55 (Vekol Road TI)	R17-6-405; R17-6-406; R17-6-408; R17-6-409			Over 14' - 16' = R	
Interstate 8	MP 144.55 (Vekol Road Underpass - Structure 550)	R17-6-405; R17-6-406; R17-6-408; R17-6-409	15' 11"		Over 14' - 16' = R	
Interstate 8	MP 144.55 (Vekol Road TI) to MP 151.70 (SR 84 TI)	R17-6-405; R17-6-406; R17-6-408; R17-6-409			Over 14' - 16' = R	
Interstate 8	MP 151.70 Eastbound (SR 84 TI Underpass - Structure 1063)	R17-6-405; R17-6-406; R17-6-408; R17-6-409	15' 11"		Over 14' - 16' = R	
Interstate 8	MP 151.70 (SR 84 TI) to MP 162.50 (Murphy Road)	R17-6-405; R17-6-406; R17-6-408; R17-6-409			Over 14' - 16' = R	
Interstate 8	MP 162.50 Westbound (Murphy Road Underpass - Structure 1091)	R17-6-405; R17-6-406; R17-6-408; R17-6-409	15' 11"		Over 14' - 16' = R	
Interstate 8	MP 162.50 (Murphy Road) to MP 172.55 (Thornton Road)	R17-6-405; R17-6-406; R17-6-408; R17-6-409			Over 14' - 16' = R	
Interstate 8	MP 172.55 (Thornton Road Underpass)	R17-6-405; R17-6-406; R17-6-408; R17-6-409	15' 9"		Over 14' - 16' = R	
Interstate 8	MP 172.55 (Thornton Road) to MP 173.53 (Chuichu Road)	R17-6-405; R17-6-406; R17-6-408; R17-6-409			Over 14' - 16' = R	
Interstate 8	MP 173.53 Eastbound (Chuichu Road Underpass)	R17-6-405; R17-6-406; R17-6-408; R17-6-409	15' 10"		Over 14' - 16' = R	
Interstate 8	MP 173.53 (Chuichu Road) to MP 178.70 (Junction I-10)	R17-6-405; R17-6-406; R17-6-408; R17-6-409			Over 14' - 16' = R	
Interstate 10	MP 0.00 (California State Line) to MP 5.84 (Tom Wells Road TI)	R17-6-405; R17-6-406; R17-6-408; R17-6-409			Over 14' - 16' = R	
Interstate 10	MP 5.84 Eastbound (Tom Wells Road Underpass - Structure 767)	R17-6-405; R17-6-406; R17-6-408; R17-6-409	15' 10"		Over 14' - 16' = R	
Interstate 10	MP 5.84 Westbound (Tom Wells Road Underpass - Structure 767)	R17-6-405; R17-6-406; R17-6-408; R17-6-409	15' 11"		Over 14' - 16' = R	
Interstate 10	MP 5.84 (Tom Wells Road TI) MP 17.50 (West Quartzsite TI)	R17-6-405; R17-6-406; R17-6-408; R17-6-409			Over 14' - 16' = R	
Interstate 10	MP 17.50 (West Quartzsite Underpass)	R17-6-405; R17-6-406; R17-6-408; R17-6-409	15' 8"		Over 14' - 16' = R	
Interstate 10	MP 17.50 (West Quartzsite TI) to MP 26.65 (Gold Nugget Mountain)	R17-6-405; R17-6-406; R17-6-408; R17-6-409			Over 14' - 16' = R	
Interstate 10	MP 26.65 Westbound (Gold Nugget Mountain)	R17-6-405; R17-6-406; R17-6-408; R17-6-409	15' 10"		Over 14' - 16' = R	
Interstate 10	MP 26.65 (Gold Nugget Mountain) to MP 33.78 (Ramsey Mine TI)	R17-6-405; R17-6-406; R17-6-408; R17-6-409			Over 14' - 16' = R	

**ODPC Final Draft -  
(10/21/2011)**  
Not yet approved or proposed

Route	Restriction Location (MP = Mile Post)	Movement Subject to:	Height	Length	Width	Weight (in lbs)
<b>Escort requirements: F = front escort, R = rear escort, F/R = front and rear escort, and LE = law enforcement escort</b>						
Interstate 10	MP 33.78 Eastbound (Ramsey Mine Underpass - Structure 1202)	R17-6-405; R17-6-406; R17-6-408; R17-6-409	15' 11"		Over 14' - 16' = R	
Interstate 10	MP 33.78 (Ramsey Mine TI) to MP 45.34 (Vicksburg Road TI)	R17-6-405; R17-6-406; R17-6-408; R17-6-409			Over 14' - 16' = R	
Interstate 10	MP 45.34 (Vicksburg Road Underpass)	R17-6-405; R17-6-406; R17-6-408; R17-6-409	15' 7"		Over 14' - 16' = R	
Interstate 10	MP 45.34 (Vicksburg Road TI) to MP 69.60 (Avenue 75E TI)	R17-6-405; R17-6-406; R17-6-408; R17-6-409			Over 14' - 16' = R	
Interstate 10	MP 69.60 Westbound (Avenue 75E Underpass - Structure 1283)	R17-6-405; R17-6-406; R17-6-408; R17-6-409	15' 11"		Over 14' - 16' = R	
Interstate 10	MP 69.60 (Avenue 75E TI) to MP 81.21 (Salome Road TI)	R17-6-405; R17-6-406; R17-6-408; R17-6-409			Over 14' - 16' = R	
Interstate 10	MP 81.21 Eastbound (Salome Road Underpass - Structure 1209)	R17-6-405; R17-6-406; R17-6-408; R17-6-409	15' 8"		Over 14' - 16' = R	
Interstate 10	MP 81.21 Westbound (Salome Road Underpass - Structure 1209)	R17-6-405; R17-6-406; R17-6-408; R17-6-409	15' 6"		Over 14' - 16' = R	
Interstate 10	MP 81.21 (Salome Road TI) to MP 101.40 (355th Avenue)	R17-6-405; R17-6-406; R17-6-408; R17-6-409			Over 14' - 16' = R	
Interstate 10	MP 101.40 Westbound (355th Avenue Underpass)	R17-6-405; R17-6-406; R17-6-408; R17-6-409	15' 8"		Over 14' - 16' = R	
Interstate 10	MP 101.40 (355th Avenue) to MP 133.98 (Junction SR 101)	R17-6-405; R17-6-406; R17-6-408; R17-6-409			Over 14' - 16' = R	
Interstate 10	MP 133.98 (Junction SR 101) to MP 139.65 (51st Avenue TI)	R17-6-404; R17-6-405; R17-6-406; R17-6-408; R17-6-409			Over 14' - 16' = R	
Interstate 10	MP 139.65 Eastbound (51st Avenue Underpass - Structure 1930)	R17-6-404; R17-6-405; R17-6-406; R17-6-408; R17-6-409	15' 11"		Over 14' - 16' = R	
Interstate 10	MP 139.65 (51st Avenue TI) to MP 145.19 (Deck Park Tunnel)	R17-6-404; R17-6-405; R17-6-406; R17-6-408; R17-6-409			Over 14' - 16' = R	
Interstate 10	MP 145.19 Eastbound (Deck Park Tunnel)	R17-6-404; R17-6-405; R17-6-406; R17-6-408; R17-6-409	15' 7"		Over 14' - 16' = R	
Interstate 10	MP 145.19 (Deck Park Tunnel) to MP 147.21 (SR 51 TI)	R17-6-404; R17-6-405; R17-6-406; R17-6-408; R17-6-409			Over 14' - 16' = R	

**ODPC Final Draft -  
(10/21/2011)**  
Not yet approved or proposed

Route	Restriction Location (MP = Mile Post)	Movement Subject to:	Height	Length	Width	Weight (in lbs)
<b>Escort requirements: F = front escort, R = rear escort, F/R = front and rear escort, and LE = law enforcement escort</b>						
Interstate 10	MP 147.21 (SR 51 Underpass)	R17-6-404; R17-6-405; R17-6-406; R17-6-408; R17-6-409	15' 2"		Over 14' - 16' = R	
Interstate 10	MP 147.21 (SR 51 TI) to MP 161.35 (Junction SR 202, Santan)	R17-6-404; R17-6-405; R17-6-406; R17-6-408; R17-6-409			Over 14' - 16' = R	
Interstate 10	MP 161.35 (Junction SR 202, Santan) to MP 167.47 (Riggs Road TI)	R17-6-405; R17-6-406; R17-6-408; R17-6-409			Over 14' - 16' = R	
Interstate 10	MP 167.47 (Riggs Road Underpass)	R17-6-405; R17-6-406; R17-6-408; R17-6-409	15' 9"		Over 14' - 16' = R	
Interstate 10	MP 167.47 (Riggs Road TI) to MP 169.85 (Goodyear Underpass)	R17-6-405; R17-6-406; R17-6-408; R17-6-409			Over 14' - 16' = R	
Interstate 10	MP 169.85 Eastbound (Goodyear Underpass)	R17-6-405; R17-6-406; R17-6-408; R17-6-409	15' 10"		Over 14' - 16' = R	
Interstate 10	MP 169.85 (Goodyear Underpass) to MP 174.63 (Nelson Road)	R17-6-405; R17-6-406; R17-6-408; R17-6-409			Over 14' - 16" = R	
Interstate 10	MP 174.63 (Nelson Road Underpass - Structure 1213)	R17-6-405; R17-6-406; R17-6-408; R17-6-409	15' 11"		Over 14' - 16" = R	
Interstate 10	MP 174.63 (Nelson Road) to MP 175.81 (Casa Blanca TI)	R17-6-405; R17-6-406; R17-6-408; R17-6-409			Over 14' - 16" = R	
Interstate 10	MP 175.81 Eastbound (Casa Blanca TI Underpass - Structure 1214)	R17-6-405; R17-6-406; R17-6-408; R17-6-409	15' 11"		Over 14' - 16" = R	
Interstate 10	MP 175.81 Westbound (Casa Blanca TI Underpass - Structure 1214)	R17-6-405; R17-6-406; R17-6-408; R17-6-409	15' 10"		Over 14' - 16" = R	
Interstate 10	MP 175.81 (Casa Blanca TI) to MP 177.76 (Gas Line Road TI)	R17-6-405; R17-6-406; R17-6-408; R17-6-409			Over 14' - 16" = R	
Interstate 10	MP 177.76 Eastbound (Gas Line Road Underpass - Structure 1215)	R17-6-405; R17-6-406; R17-6-408; R17-6-409	15' 11"		Over 14' - 16" = R	
Interstate 10	MP 177.76 (Gas Line Road TI) to MP 179.39 (Seed Farm Road TI)	R17-6-405; R17-6-406; R17-6-408; R17-6-409			Over 14' - 16" = R	
Interstate 10	MP 179.39 Westbound (Seed Farm Road Underpass - Structure 1216)	R17-6-405; R17-6-406; R17-6-408; R17-6-409	15' 10"		Over 14' - 16" = R	
Interstate 10	MP 179.39 (Seed Farm Road TI) to MP 195.89 (Earley Road)	R17-6-405; R17-6-406; R17-6-408; R17-6-409			Over 14' - 16" = R	
Interstate 10	MP 195.89 (Earley Road Underpass - Structure 1158)	R17-6-405; R17-6-406; R17-6-408; R17-6-409	15' 11"		Over 14' - 16" = R	
Interstate 10	MP 195.89 (Earley Road) to MP 203.84 (Toltec Road TI)	R17-6-405; R17-6-406; R17-6-408; R17-6-409			Over 14' - 16" = R	

**ODPC Final Draft -  
(10/21/2011)**  
Not yet approved or proposed

Route	Restriction Location (MP = Mile Post)	Movement Subject to:	Height	Length	Width	Weight (in lbs)
<b>Escort requirements: F = front escort, R = rear escort, F/R = front and rear escort, and LE = law enforcement escort</b>						
Interstate 10	MP 203.84 Westbound (Toltec Road Underpass - Structure 2152)	R17-6-405; R17-6-406; R17-6-408; R17-6-409	15' 11"		Over 14' - 16" = R	
Interstate 10	MP 203.84 (Toltec Road TI) to MP 205.45 (Battaglia Underpass)	R17-6-405; R17-6-406; R17-6-408; R17-6-409			Over 14' - 16" = R	
Interstate 10	MP 205.45 Eastbound (Battaglia Underpass)	R17-6-405; R17-6-406; R17-6-408; R17-6-409	15' 9"		Over 14' - 16' = R	
Interstate 10	MP 205.45 Westbound (Battaglia Underpass)	R17-6-405; R17-6-406; R17-6-408; R17-6-409	15' 10"		Over 14' - 16' = R	
Interstate 10	MP 205.45 (Battaglia Underpass) to MP 208.79 (Sunshine Blvd TI)	R17-6-405; R17-6-406; R17-6-408; R17-6-409			Over 14' - 16' = R	
Interstate 10	MP 208.79 Westbound (Sunshine Blvd Underpass - Structure 945)	R17-6-405; R17-6-406; R17-6-408; R17-6-409	15' 11"		Over 14' - 16' = R	
Interstate 10	MP 208.79 (Sunshine Blvd TI) to MP 226.45 (Red Rock Road TI)	R17-6-405; R17-6-406; R17-6-408; R17-6-409			Over 14' - 16' = R	
Interstate 10	MP 226.45 Eastbound (Red Rock Road Underpass - Structure 592)	R17-6-405; R17-6-406; R17-6-408; R17-6-409	15' 11"		Over 14' - 16' = R	
Interstate 10	MP 226.45 Westbound (Red Rock Road Underpass - Structure 592)	R17-6-405; R17-6-406; R17-6-408; R17-6-409	15' 10"		Over 14' - 16' = R	
Interstate 10	MP 226.45 (Red Rock Road TI) to MP 236.42 (Marana Road)	R17-6-405; R17-6-406; R17-6-408; R17-6-409			Over 14' - 16' = R	
Interstate 10	MP 236.42 (Marana Road) to MP 270.57 (Kolb Road TI)	R17-6-405; R17-6-406; R17-6-408; R17-6-409			Over 14' - 16' = R	
Interstate 10	MP 270.57 Eastbound (Kolb Road Underpass - Structure 1823)	R17-6-405; R17-6-406; R17-6-408; R17-6-409	15' 11"		Over 14' - 16' = R	
Interstate 10	MP 270.57 (Kolb Road TI) to MP 273.14 (Rita Road TI)	R17-6-405; R17-6-406; R17-6-408; R17-6-409			Over 14' - 16' = R	
Interstate 10	MP 273.14 Eastbound (Rita Road Underpass - Structure 711)	R17-6-405; R17-6-406; R17-6-408; R17-6-409	15' 11"		Over 14' - 16' = R	
Interstate 10	MP 273.14 (Rita Road TI) to MP 275.49 (Houghton Road TI)	R17-6-405; R17-6-406; R17-6-408; R17-6-409			Over 14' - 16' = R	
Interstate 10	MP 275.49 Westbound (Houghton Road Underpass - Structure 713)	R17-6-405; R17-6-406; R17-6-408; R17-6-409	15' 10"		Over 14' - 16' = R	
Interstate 10	MP 275.49 (Houghton Road TI) to MP 279.37 (Vail Road TI)	R17-6-405; R17-6-406; R17-6-408; R17-6-409			Over 14' - 16' = R	
Interstate 10	MP 279.37 Westbound (Vail Road Underpass)	R17-6-405; R17-6-406; R17-6-408; R17-6-409	15' 10"		Over 14' - 16' = R	
Interstate 10	MP 279.37 (Vail Road) to MP 289.35 (Railroad Underpass, Pantano)	R17-6-405; R17-6-406; R17-6-408; R17-6-409			Over 14' - 16' = R	

**ODPC Final Draft -  
(10/21/2011)**  
Not yet approved or proposed

Route	Restriction Location (MP = Mile Post)	Movement Subject to:	Height	Length	Width	Weight (in lbs)
<b>Escort requirements: F = front escort, R = rear escort, F/R = front and rear escort, and LE = law enforcement escort</b>						
Interstate 10	MP 289.35 Eastbound (Railroad Underpass, Pantano)	R17-6-405; R17-6-406; R17-6-408; R17-6-409	15'		Over 14' - 16' = R	
Interstate 10	MP 289.35 Westbound (Railroad Underpass, Pantano)	R17-6-405; R17-6-406; R17-6-408; R17-6-409	15'		Over 14' - 16' = R	
Interstate 10	MP 289.35 (Railroad Underpass, Pantano) to MP 336.90 (W. Willcox TI)	R17-6-405; R17-6-406; R17-6-408; R17-6-409			Over 14' - 16' = R	
Interstate 10	MP 336.90 Westbound (W. Willcox Underpass - Structure 1113)	R17-6-405; R17-6-406; R17-6-408; R17-6-409	15' 10"		Over 14' - 16' = R	
Interstate 10	MP 336.90 (W. Willcox TI) to MP 339.46 (Airport Road)	R17-6-405; R17-6-406; R17-6-408; R17-6-409			Over 14' - 16' = R	
Interstate 10	MP 339.46 Eastbound (Airport Road Underpass)	R17-6-405; R17-6-406; R17-6-408; R17-6-409	15' 9"		Over 14' - 16' = R	
Interstate 10	MP 339.46 (Airport Road) to MP 378.93 (West San Simon TI)	R17-6-405; R17-6-406; R17-6-408; R17-6-409			Over 14' - 16' = R	
Interstate 10	MP 378.93 Eastbound (West San Simon Underpass)	R17-6-405; R17-6-406; R17-6-408; R17-6-409	15' 10"		Over 14' - 16' = R	
Interstate 10	MP 378.93 Westbound (West San Simon Underpass)	R17-6-405; R17-6-406; R17-6-408; R17-6-409	15' 11"		Over 14' - 16' = R	
Interstate 10	MP 378.93 (West San Simon TI) to MP 382.35 (East San Simon TI)	R17-6-405; R17-6-406; R17-6-408; R17-6-409			Over 14' - 16' = R	
Interstate 10	MP 382.35 Eastbound (East San Simon Underpass)	R17-6-405; R17-6-406; R17-6-408; R17-6-409	15' 10"		Over 14' - 16' = R	
Interstate 10	MP 382.35 (East San Simon TI) to MP 391.23 (New Mexico State Line)	R17-6-405; R17-6-406; R17-6-408; R17-6-409			Over 14' - 16' = R	
Interstate 15	MP 0.00 (Nevada State Line) to MP 15.38 (Virgin River Bridge # 5)	R17-6-405; R17-6-406; R17-6-408; R17-6-409		Over 100' unarticulated = F/R + 2 LE	Over 14' - 16' = F/R + 2 LE	
Interstate 15	MP 15.38 Northbound (Virgin River Bridge #5 - Structure 1617)	R17-6-405; R17-6-406; R17-6-408; R17-6-409		Over 100' unarticulated = F/R + 2 LE	Over 14' - 16' = F/R + 2 LE	Class A permitted vehicles with a gross weight of: 150,000 or less - no additional restrictions; 150,001 through 250,000 - drivers shall: Coordinate road closures by or under the direction of law enforcement; and Cross on center of bridge at a constant speed of no more than 10 mph while on bridge.  Class C permitted vehicles with a gross weight of over 250,000 require special analysis and approval from the ADOT Bridge Group.

**ODPC Final Draft -  
(10/21/2011)**

Not yet approved or proposed

Route	Restriction Location (MP = Mile Post)	Movement Subject to:	Height	Length	Width	Weight (in lbs)
<b>Escort requirements: F = front escort, R = rear escort, F/R = front and rear escort, and LE = law enforcement escort</b>						
Interstate 15	MP 15.38 Southbound (Virgin River Bridge #5 - Structure 1618)	R17-6-405; R17-6-406; R17-6-408; R17-6-409		Over 100' unarticulated = F/R + 2 LE	Over 14' - 16' = F/R + 2 LE	Class A permitted vehicles with a gross weight of: 150,000 or less - no additional restrictions; 150,001 through 250,000 - drivers shall: Coordinate road closures by or under the direction of law enforcement; and Cross on center of bridge at a constant speed of no more than 10 mph while on bridge.  Class C permitted vehicles with a gross weight of over 250,000 require special analysis and approval from the ADOT Bridge Group.
Interstate 15	MP 15.38 (Virgin River Bridge #5) to MP 29.40 (Utah State Line)	R17-6-405; R17-6-406; R17-6-408; R17-6-409		Over 100' unarticulated = F/R + 2 LE	Over 14' - 16' = F/R + 2 LE	
Interstate 17	MP 193.94 (Beginning of route at Junction I-10) to MP 198.84 (Buckeye Road)	R17-6-404; R17-6-405; R17-6-406; R17-6-408; R17-6-409			Over 14' - 16' = R	
Interstate 17	MP 198.84 Northbound (Buckeye Road Underpass)	R17-6-404; R17-6-405; R17-6-406; R17-6-408; R17-6-409	15'		Over 14' - 16' = R	
Interstate 17	MP 198.84 Southbound (Buckeye Road Underpass)	R17-6-404; R17-6-405; R17-6-406; R17-6-408; R17-6-409	15' 5"		Over 14' - 16' = R	
Interstate 17	MP 198.84 (Buckeye Road) to MP 199.15 (Grant Street)	R17-6-404; R17-6-405; R17-6-406; R17-6-408; R17-6-409			Over 14' - 16' = R	
Interstate 17	MP 199.15 (Grant Street Underpass)	R17-6-404; R17-6-405; R17-6-406; R17-6-408; R17-6-409	15' 6"		Over 14' - 16' = R	
Interstate 17	MP 199.15 (Grant Street) to MP 199.35 (Railroad Underpass)	R17-6-404; R17-6-405; R17-6-406; R17-6-408; R17-6-409			Over 14' - 16' = R	
Interstate 17	MP 199.35 Northbound (Railroad Underpass)	R17-6-404; R17-6-405; R17-6-406; R17-6-408; R17-6-409	15' 8"		Over 14' - 16' = R	
Interstate 17	MP 199.35 Southbound (Railroad Underpass)	R17-6-404; R17-6-405; R17-6-406; R17-6-408; R17-6-409	15' 7"		Over 14' - 16' = R	

**ODPC Final Draft -  
(10/21/2011)**  
Not yet approved or proposed

Route	Restriction Location (MP = Mile Post)	Movement Subject to:	Height	Length	Width	Weight (in lbs)
<b>Escort requirements: F = front escort, R = rear escort, F/R = front and rear escort, and LE = law enforcement escort</b>						
Interstate 17	MP 199.35 (Railroad Underpass) to MP 199.56 (Jefferson Street)	R17-6-404; R17-6-405; R17-6-406; R17-6-408; R17-6-409			Over 14' - 16' = R	
Interstate 17	MP 199.56 Northbound (Jefferson Street Underpass - Structure 554)	R17-6-404; R17-6-405; R17-6-406; R17-6-408; R17-6-409	15' 8"		Over 14' - 16' = R	
Interstate 17	MP 199.56 Southbound (Jefferson Street Underpass - Structure 554)	R17-6-404; R17-6-405; R17-6-406; R17-6-408; R17-6-409	15' 7"		Over 14' - 16' = R	
Interstate 17	MP 199.56 (Jefferson Street) to MP 214.74 (Utopia Road Ramp C)	R17-6-404; R17-6-405; R17-6-406; R17-6-408; R17-6-409			Over 14' - 16' = R	
Interstate 17	MP 214.74 Northbound (Utopia Road Ramp C - Structure 2138)	R17-6-404; R17-6-405; R17-6-406; R17-6-408; R17-6-409	15' 11"		Over 14' - 16' = R	
Interstate 17	MP 214.74 (Utopia Road Ramp C) to MP 214.96 (Junction SR 101)	R17-6-404; R17-6-405; R17-6-406; R17-6-408; R17-6-409			Over 14' - 16' = R	
Interstate 17	MP 214.96 (Junction SR 101) to MP 223.99 (Junction SR 74)	R17-6-405; R17-6-406; R17-6-408; R17-6-409			Over 14' - 16' = R	
Interstate 17	MP 224.00 Southbound (Carefree Highway Underpass - Structure 2845)	R17-6-405; R17-6-406; R17-6-407; R17-6-408; R17-6-409	15' 9"		Over 14' - 16' = R	
Interstate 17	MP 224.00 (Carefree Highway TI) to MP 229.07 (Anthem Road)	R17-6-405; R17-6-406; R17-6-407; R17-6-408; R17-6-409			Over 14' - 16' = R	
Interstate 17	MP 229.07 (Anthem Road) to MP 235.94 (Table Mesa TI)	R17-6-405; R17-6-406; R17-6-407; R17-6-408; R17-6-409			Over 14' - 16' = F/R	
Interstate 17	MP 235.94 Southbound (Table Mesa Underpass - Structure 1294)	R17-6-405; R17-6-406; R17-6-407; R17-6-408; R17-6-409	15' 10"		Over 14' - 16' = F/R	
Interstate 17	MP 235.94 (Table Mesa TI) to MP 242.15 (Rock Spring)	R17-6-405; R17-6-406; R17-6-407; R17-6-408; R17-6-409			Over 14' - 16' = F/R	
Interstate 17	MP 242.15 (Rock Spring)	R17-6-405; R17-6-406; R17-6-407; R17-6-408; R17-6-409	15' 10"		Over 14' - 16' = R	

**ODPC Final Draft -  
(10/21/2011)**  
Not yet approved or proposed

Route	Restriction Location (MP = Mile Post)	Movement Subject to:	Height	Length	Width	Weight (in lbs)
<b>Escort requirements: F = front escort, R = rear escort, F/R = front and rear escort, and LE = law enforcement escort</b>						
Interstate 17	MP 242.15 (Rock Spring TI) to MP 262.65 (Cordes Jct TI)	R17-6-405; R17-6-406; R17-6-407; R17-6-408; R17-6-409			Over 14' - 16' = R	
Interstate 17	MP 262.65 Southbound (Cordes Jct Underpass - Structure 585)	R17-6-405; R17-6-406; R17-6-407; R17-6-408; R17-6-409	15' 10"		Over 14' - 16' = R	
Interstate 17	MP 262.65 (Cordes Jct TI) to MP 262.70 (Junction SR 69)	R17-6-405; R17-6-406; R17-6-407; R17-6-408; R17-6-409			Over 14' - 16' = R	
Interstate 17	MP 262.70 (Junction SR 69) to MP 289.97 (Middle Verde TI)	R17-6-405; R17-6-406; R17-6-407; R17-6-408; R17-6-409			Over 14' - 16' = R	
Interstate 17	MP 289.97 Southbound (Middle Verde Underpass - Structure 1733)	R17-6-405; R17-6-406; R17-6-407; R17-6-408; R17-6-409	15' 11"		Over 14' - 16' = R	
Interstate 17	MP 289.97 (Middle Verde TI) to MP 293.26 (Cornville/McGuireville TI)	R17-6-405; R17-6-406; R17-6-407; R17-6-408; R17-6-409			Over 14' - 16' = R	
Interstate 17	MP 293.26 Southbound (Cornville/McGuireville Underpass - Structure 652)	R17-6-405; R17-6-406; R17-6-407; R17-6-408; R17-6-409	14' 8"		Over 14' - 16' = R	
Interstate 17	MP 293.26 (Cornville/McGuireville TI) to MP 340.05 (End of route at Junction I-40)	R17-6-405; R17-6-406; R17-6-407; R17-6-408; R17-6-409			Over 14' - 16' = R	
Interstate 19	MP 0.00 (US/Mexico Border) to MP 5.30 (Potrero TI)	R17-6-405; R17-6-406; R17-6-408; R17-6-409			Over 14' - 16' = R	
Interstate 19	MP 5.30 Southbound (Potrero TI Ramp - Structure 1302)	R17-6-405; R17-6-406; R17-6-408; R17-6-409	15' 9"		Over 14' - 16' = R	
Interstate 19	MP 5.30 (Potrero TI) to MP 13.96 (Peck Canyon TI)	R17-6-405; R17-6-406; R17-6-408; R17-6-409			Over 14' - 16' = R	
Interstate 19	MP 13.96 Northbound (Peck Canyon)	R17-6-405; R17-6-406; R17-6-408; R17-6-409	15' 10"		Over 14' - 16' = R	
Interstate 19	MP 13.96 (Peck Canyon TI) to MP 26.54 (Agua Linda TI)	R17-6-405; R17-6-406; R17-6-408; R17-6-409			Over 14' - 16' = R	
Interstate 19	MP 26.54 Northbound (Agua Linda Underpass - Structure 1739)	R17-6-405; R17-6-406; R17-6-408; R17-6-409	15' 10"		Over 14' - 16' = R	
Interstate 19	MP 26.54 (Agua Linda TI) to MP 59.09 (Valencia Road, Kilometer Post 95.00)	R17-6-405; R17-6-406; R17-6-408; R17-6-409			Over 14' - 16' = R	

**ODPC Final Draft -  
(10/21/2011)**  
Not yet approved or proposed

Route	Restriction Location (MP = Mile Post)	Movement Subject to:	Height	Length	Width	Weight (in lbs)
<b>Escort requirements: F = front escort, R = rear escort, F/R = front and rear escort, and LE = law enforcement escort</b>						
Interstate 19	MP 59.09 (Valencia Road, Kilometer Post 95.00) to MP 60.95 (Irvington TI)	R17-6-404; R17-6-405; R17-6-406; R17-6-408; R17-6-409			Over 14' - 16' = R	
Interstate 19	MP 60.95 Southbound (Irvington Underpass - Structure 1123)	R17-6-404; R17-6-405; R17-6-406; R17-6-408; R17-6-409	15' 11"		Over 14' - 16' = R	
Interstate 19	MP 60.95 (Irvington TI) to MP 61.90 (Ajo Way)	R17-6-404; R17-6-405; R17-6-406; R17-6-408; R17-6-409			Over 14' - 16' = R	
Interstate 19	MP 61.90 Southbound (Ajo Way)	R17-6-404; R17-6-405; R17-6-406; R17-6-408; R17-6-409	15' 9"		Over 14' - 16' = R	
Interstate 19	MP 61.90 (Ajo Way) to MP 63.09 (Junction I-10)	R17-6-404; R17-6-405; R17-6-406; R17-6-408; R17-6-409			Over 14' - 16' = R	
Interstate 40	MP 0.00 (California State Line) to MP 26.17 (East Yucca TI)	R17-6-405; R17-6-406; R17-6-408; R17-6-409			Over 14' - 16' = R	
Interstate 40	MP 26.17 Eastbound (East Yucca Underpass - Structure 923)	R17-6-405; R17-6-406; R17-6-408; R17-6-409	15' 10"		Over 14' - 16' = R	
Interstate 40	MP 26.17 (East Yucca TI) to MP 37.03 (Griffith Road TI)	R17-6-405; R17-6-406; R17-6-408; R17-6-409			Over 14' - 16' = R	
Interstate 40	MP 37.03 Eastbound (Griffith Road Underpass - Structure 928)	R17-6-405; R17-6-406; R17-6-408; R17-6-409	15' 10"		Over 14' - 16' = R	
Interstate 40	MP 37.03 (Griffith Road TI) to MP 59.71 (DW Ranch Road TI)	R17-6-405; R17-6-406; R17-6-408; R17-6-409			Over 14' - 16' = R	
Interstate 40	MP 59.71 Westbound (DW Ranch Road Underpass - Structure 1249)	R17-6-405; R17-6-406; R17-6-408; R17-6-409	15' 10"		Over 14' - 16' = R	
Interstate 40	MP 59.71 (DW Ranch Road TI) to MP 71.99 (Highway 93 TI)	R17-6-405; R17-6-406; R17-6-408; R17-6-409			Over 14' - 16' = R	
Interstate 40	MP 71.99 Eastbound (Highway 93 Underpass - Structure 1082)	R17-6-405; R17-6-406; R17-6-408; R17-6-409	15' 10"		Over 14' - 16' = R	
Interstate 40	MP 71.99 (Highway 93 TI) to MP 87.57 (Willow Ranch Road TI)	R17-6-405; R17-6-406; R17-6-408; R17-6-409			Over 14' - 16' = R	
Interstate 40	MP 87.57 Westbound (Willow Ranch Road Underpass - Structure 1770)	R17-6-405; R17-6-406; R17-6-408; R17-6-409	15' 7"		Over 14' - 16' = R	
Interstate 40	MP 87.57 (Willow Ranch Road TI) to MP 117.87 (Canyon Mouth Dam)	R17-6-405; R17-6-406; R17-6-408; R17-6-409			Over 14' - 16' = R	
Interstate 40	MP 117.87 Eastbound (Canyon Mouth Dam Underpass - Structure 1256)	R17-6-405; R17-6-406; R17-6-408; R17-6-409	15' 11"		Over 14' - 16' = R	

**ODPC Final Draft -  
(10/21/2011)**  
Not yet approved or proposed

Route	Restriction Location (MP = Mile Post)	Movement Subject to:	Height	Length	Width	Weight (in lbs)
<b>Escort requirements: F = front escort, R = rear escort, F/R = front and rear escort, and LE = law enforcement escort</b>						
Interstate 40	MP 117.87 (Canyon Mouth Dam) to MP 139.88 (Crookton Road TI)	R17-6-405; R17-6-406; R17-6-408; R17-6-409			Over 14' - 16' = R	
Interstate 40	MP 139.88 Westbound (Crookton Road Underpass - Structure 1177)	R17-6-405; R17-6-406; R17-6-408; R17-6-409	15' 9"		Over 14' - 16' = R	
Interstate 40	MP 139.88 (Crookton Road TI) to MP 167.52 (Garland Prairie TI)	R17-6-405; R17-6-406; R17-6-408; R17-6-409			Over 14' - 16' = R	
Interstate 40	MP 167.52 (Garland Prairie Underpass - Structure 739)	R17-6-405; R17-6-406; R17-6-408; R17-6-409	15' 11"		Over 14' - 16' = R	
Interstate 40	MP 167.52 (Garland Prairie TI) to MP 178.24 (Parks Road TI)	R17-6-405; R17-6-406; R17-6-408; R17-6-409			Over 14' - 16' = R	
Interstate 40	MP 178.24 Eastbound (Parks Road Underpass - Structure 743)	R17-6-405; R17-6-406; R17-6-408; R17-6-409	15' 11"		Over 14' - 16' = R	
Interstate 40	MP 178.24 (Parks Road TI) to MP 201.10 (Country Club Road TI)	R17-6-405; R17-6-406; R17-6-408; R17-6-409			Over 14' - 16' = R	
Interstate 40	MP 201.10 Westbound (Country Club Road Underpass - Structure 1926)	R17-6-405; R17-6-406; R17-6-408; R17-6-409	15' 11"		Over 14' - 16' = R	
Interstate 40	MP 201.10 (Country Club Road TI) to MP 204.87 (Walnut Canyon TI)	R17-6-405; R17-6-406; R17-6-408; R17-6-409			Over 14' - 16' = R	
Interstate 40	MP 204.87 Eastbound (Walnut Canyon Underpass)	R17-6-405; R17-6-406; R17-6-408; R17-6-409	15' 9"		Over 14' - 16' = R	
Interstate 40	MP 204.87 (Walnut Canyon TI) to MP 207.24 (Cosnino Road)	R17-6-405; R17-6-406; R17-6-408; R17-6-409			Over 14' - 16' = R	
Interstate 40	MP 207.24 Westbound (Cosnino Road Underpass)	R17-6-405; R17-6-406; R17-6-408; R17-6-409	15' 6"		Over 14' - 16' = R	
Interstate 40	MP 207.24 (Cosnino Road) to MP 211.16 (Winona TI)	R17-6-405; R17-6-406; R17-6-408; R17-6-409			Over 14' - 16' = R	
Interstate 40	MP 211.16 Westbound (Winona Underpass)	R17-6-405; R17-6-406; R17-6-408; R17-6-409	15' 9"		Over 14' - 16' = R	
Interstate 40	MP 211.16 (Winona TI) to MP 280.64 (Hunt Road TI)	R17-6-405; R17-6-406; R17-6-408; R17-6-409			Over 14' - 16' = R	
Interstate 40	MP 280.64 Westbound (Hunt Road Underpass - Structure 930)	R17-6-405; R17-6-406; R17-6-408; R17-6-409	15' 9"		Over 14' - 16' = R	
Interstate 40	MP 280.64 (Hunt Road TI) to MP 320.00 (Pinta TI)	R17-6-405; R17-6-406; R17-6-408; R17-6-409			Over 14' - 16' = R	
Interstate 40	MP 320.00 Westbound (Pinta Underpass - Structure 708)	R17-6-405; R17-6-406; R17-6-408; R17-6-409	15' 9"		Over 14' - 16' = R	
Interstate 40	MP 320.00 (Pinta TI) to MP 325.92 (Navajo TI)	R17-6-405; R17-6-406; R17-6-408; R17-6-409			Over 14' - 16' = R	

**ODPC Final Draft -  
(10/21/2011)**  
Not yet approved or proposed

Route	Restriction Location (MP = Mile Post)	Movement Subject to:	Height	Length	Width	Weight (in lbs)
<b>Escort requirements: F = front escort, R = rear escort, F/R = front and rear escort, and LE = law enforcement escort</b>						
Interstate 40	MP 325.92 Eastbound (Navajo Underpass - Structure 709)	R17-6-405; R17-6-406; R17-6-408; R17-6-409	15' 11"		Over 14' - 16' = R	
Interstate 40	MP 325.92 Westbound (Navajo Underpass - Structure 709)	R17-6-405; R17-6-406; R17-6-408; R17-6-409	15' 9"		Over 14' - 16' = R	
Interstate 40	MP 325.92 (Navajo TI) to MP 330.00 (Mc Carroll Road TI)	R17-6-405; R17-6-406; R17-6-408; R17-6-409			Over 14' - 16' = R	
Interstate 40	MP 330.00 Eastbound (Mc Carroll Road Underpass)	R17-6-405; R17-6-406; R17-6-408; R17-6-409	15' 11"		Over 14' - 16' = R	
Interstate 40	MP 330.00 Westbound (Mc Carroll Road Underpass)	R17-6-405; R17-6-406; R17-6-408; R17-6-409	15' 10"		Over 14' - 16' = R	
Interstate 40	MP 330.00 (Mc Carroll Road TI) to MP 333.41 (Chambers TI)	R17-6-405; R17-6-406; R17-6-408; R17-6-409			Over 14' - 16' = R	
Interstate 40	MP 333.41 Westbound (Chambers Underpass - Structure 814)	R17-6-405; R17-6-406; R17-6-408; R17-6-409	15' 9"		Over 14' - 16' = R	
Interstate 40	MP 333.41 (Chambers TI) to MP 339.46 (Sanders TI)	R17-6-405; R17-6-406; R17-6-408; R17-6-409			Over 14' - 16' = R	
Interstate 40	MP 339.46 Westbound (Sanders Underpass - Structure 815)	R17-6-405; R17-6-406; R17-6-408; R17-6-409	15' 10"		Over 14' - 16' = R	
Interstate 40	MP 339.46 (Sanders TI) to MP 341.81 (Ortega Road TI)	R17-6-405; R17-6-406; R17-6-408; R17-6-409			Over 14' - 16' = R	
Interstate 40	MP 341.81 Westbound (Ortega Road Underpass - Structure 816)	R17-6-405; R17-6-406; R17-6-408; R17-6-409	15' 10"		Over 14' - 16' = R	
Interstate 40	MP 341.81 (Ortega Road TI) to MP 343.83 (Querino TI)	R17-6-405; R17-6-406; R17-6-408; R17-6-409			Over 14' - 16' = R	
Interstate 40	MP 343.83 Eastbound (Querino Underpass - Structure 951)	R17-6-405; R17-6-406; R17-6-408; R17-6-409	15' 10"		Over 14' - 16' = R	
Interstate 40	MP 343.83 (Querino TI) to MP 348.16 (Houck TI)	R17-6-405; R17-6-406; R17-6-408; R17-6-409			Over 14' - 16' = R	
Interstate 40	MP 348.16 Eastbound (Houck Underpass - Structure 955)	R17-6-405; R17-6-406; R17-6-408; R17-6-409	15' 11"		Over 14' - 16' = R	
Interstate 40	MP 348.16 (Houck TI) to MP 359.63 (New Mexico State Line)	R17-6-405; R17-6-406; R17-6-408; R17-6-409			Over 14' - 16' = R	
Interstate 40 (Frontage Road)	MP 300.75 - (Little Lithodendron Bridge - South Frontage Road - Structure 2057)	R17-6-406; R17-6-408			Over 14' - 16' = R	20,000
SB 8 (State Business 8)	MP 0.00 (California State Line) to MP 11.50 (End of route, near I-8 east of Yuma)	R17-6-404; R17-6-405; R17-6-406; R17-6-408; R17-6-409			Over 14' - 16' = F/R	

**ODPC Final Draft -  
(10/21/2011)**  
Not yet approved or proposed

Route	Restriction Location (MP = Mile Post)	Movement Subject to:	Height	Length	Width	Weight (in lbs)
<b>Escort requirements: F = front escort, R = rear escort, F/R = front and rear escort, and LE = law enforcement escort</b>						
SB 8 (State Business 8)	MP 117.32 (Gila Bend) to MP 118.40 Southbound (Junction SR 85)	R17-6-406; R17-6-408			Over 14' - 16' = F/R	
SB 8 (State Business 8)	MP 118.40 Southbound (Junction SR 85) to MP 120.28 Northbound (Junction SR 85)	R17-6-406; R17-6-408			Over 14' - 16' = F/R	
SB 8 (State Business 8)	MP 120.28 Northbound (Junction SR 85) to MP 122.98 (Junction I-8)	R17-6-406; R17-6-408			Over 14' - 16' = F/R	
SB 10 (State Business 10)	MP 303.47 (West Benson) to MP 303.86 (West Benson Underpass)	R17-6-406; R17-6-408			Over 14' - 16' = F/R	
SB 10 (State Business 10)	MP 303.86 Westbound (West Benson Underpass - Structure 1346N)	R17-6-406; R17-6-408	15'		Over 14' - 16' = F/R	
SB 10 (State Business 10)	MP 303.86 Westbound (West Benson Underpass - Structure 1347N)	R17-6-406; R17-6-408	15' 8"		Over 14' - 16' = F/R	
SB 10 (State Business 10)	MP 303.86 (West Benson) to MP 305.79 (SR 80 Underpass)	R17-6-406; R17-6-408			Over 14' - 16' = F/R	
SB 10 (State Business 10)	MP 305.79 Eastbound (SR 80 Underpass - Structure 262)	R17-6-406; R17-6-408	15' 9"		Over 14' - 16' = F/R	
SB 10 (State Business 10)	MP 305.79 Westbound (SR 80 Underpass - Structure 262)	R17-6-406; R17-6-408	14' 5"		Over 14' - 16' = F/R	
SB 10 (State Business 10)	MP 305.79 (SR 80 Underpass) to MP 305.85 (Railroad Underpass)	R17-6-406; R17-6-408			Over 14' - 16' = F/R	
SB 10 (State Business 10)	MP 305.85 Eastbound (Railroad Underpass - Structure 264)	R17-6-406; R17-6-408	14'		Over 14' - 16' = F/R	
SB 10 (State Business 10)	MP 305.85 Westbound (Railroad Underpass - Structure 264)	R17-6-406; R17-6-408	14' 2"		Over 14' - 16' = F/R	
SB 10 (State Business 10)	MP 305.85 (Railroad Underpass) to MP 306.45 (San Pedro River Bridge)	R17-6-406; R17-6-408			Over 14' - 16' = F/R	
SB 10 (State Business 10)	MP 306.45 (San Pedro River Bridge - Structure 350)	R17-6-406; R17-6-408			Over 14' - 16' = F/R + 2 LE	<p>Class A permitted vehicles with a gross weight of: 100,000 or less - no additional restrictions; 100,001 through 150,000 - drivers shall: Coordinate road closures by or under the direction of law enforcement; and Cross on center of bridge at a constant speed of no more than 10 mph while on bridge.</p> <p>Class C permits and special analysis and approval from the ADOT Bridge Group are required for vehicles with a gross weight of 150,001 or more.</p>

**ODPC Final Draft -  
(10/21/2011)**  
Not yet approved or proposed

Route	Restriction Location (MP = Mile Post)	Movement Subject to:	Height	Length	Width	Weight (in lbs)
<b>Escort requirements: F = front escort, R = rear escort, F/R = front and rear escort, and LE = law enforcement escort</b>						
SB 10 (State Business 10)	MP 306.45 (San Pedro River Bridge) to MP 306.98 (End SB 10 at I-10 Exit #306)	R17-6-406; R17-6-408			Over 14' - 16' = F/R	
SB 10 (State Business 10)	MP 336.39 (Begin SB 10 at Exit #336) to MP 340.09 (Junction SR 186)	R17-6-406; R17-6-408			Over 14' - 16' = F/R	
SB 10 (State Business 10)	MP 340.09 (Junction SR 186) to MP 344.66 (End SB 10 at I-10 Exit #344)	R17-6-406; R17-6-408			Over 14' - 16' = F/R	
SB 10 (State Business 10)	MP 362.48 (West Bowie) to MP 366.88 (End SB 10 at I-10 Exit #366)	R17-6-406; R17-6-408			Over 14' - 16' = F/R	
SB 10 (State Business 10)	MP 378.69 (West Simon) to MP 382.50 (End SB 10 at I-10 Exit #382)	R17-6-406; R17-6-408			Over 14' - 16' = F/R	
SB 19 (State Business 19)	MP 0.00 (US/Mexico Border) to MP 1.53 (Junction SR 82)	R17-6-406; R17-6-408			Over 14' - 16' = F/R	
SB 19 (State Business 19)	MP 1.53 (Junction SR 82) to MP 1.66 (Railroad Underpass)	R17-6-406; R17-6-408			Over 14' - 16' = F/R	
SB 19 (State Business 19)	MP 1.66 (Railroad Underpass - Structure 980)	R17-6-406; R17-6-408	15' 3"		Over 14' - 16' = F/R	
SB 19 (State Business 19)	MP 1.66 (Railroad Underpass) to MP 5.88 (End SB 19 at I-19)	R17-6-406; R17-6-408			Over 14' - 16' = F/R	
SB 40 (State Business 40)	MP 138.81 (West Seligman) to MP 142.20 (I-40 Underpass)	R17-6-406; R17-6-408			Over 14' - 16' = F/R	
SB 40 (State Business 40)	MP 142.20 (I-40 Underpass)	R17-6-406; R17-6-408	15' 4"		Over 14' - 16' = F/R	
SB 40 (State Business 40)	MP 142.20 (I-40 Underpass) to MP 142.21 (Railroad Underpass)	R17-6-406; R17-6-408			Over 14' - 16' = F/R	
SB 40 (State Business 40)	MP 142.21 (Railroad Underpass)	R17-6-406; R17-6-408	15' 3"		Over 14' - 16' = F/R	
SB 40 (State Business 40)	MP 142.21 (Railroad Underpass) to MP 143.04 (End SB 40 at I-40 Exit #123)	R17-6-406; R17-6-408			Over 14' - 16' = F/R	
SB 40 (State Business 40)	MP 144.82 (West Ash Fork) to MP 146.33 (East Ash Fork)	R17-6-406; R17-6-408			Over 14' - 16' = F/R	
SB 40 (State Business 40)	MP 146.33 (East Ash Fork) to MP 165.28 (Railroad Underpass)	R17-6-406; R17-6-408			Over 14' - 16' = F/R	
SB 40 (State Business 40)	MP 165.28 (Railroad Underpass - Structure 1575)	R17-6-406; R17-6-408	14' 7"		Over 14' - 16' = F/R	
SB 40 (State Business 40)	MP 165.28 (Railroad Underpass) to MP 191.44 (Junction I-40)	R17-6-406; R17-6-408			Over 14' - 16' = F/R	
SB 40 (State Business 40)	MP 191.44 (Junction I-40) to MP 191.69 (I-40 Underpass)	R17-6-406; R17-6-408			Over 12' - 16' = F/R	Coconino County Jurisdiction

**ODPC Final Draft -  
(10/21/2011)**  
Not yet approved or proposed

Route	Restriction Location (MP = Mile Post)	Movement Subject to:	Height	Length	Width	Weight (in lbs)
<b>Escort requirements: F = front escort, R = rear escort, F/R = front and rear escort, and LE = law enforcement escort</b>						
SB 40 (State Business 40)	MP 191.69 Northbound (I-40 East Underpass - Structure 1129)	R17-6-406; R17-6-408	15'		Over 12' - 16' = F/R	Coconino County Jurisdiction
SB 40 (State Business 40)	MP 191.69 Southbound (I-40 East Underpass - Structure 1129)	R17-6-406; R17-6-408	15' 2"		Over 12' - 16' = F/R	Coconino County Jurisdiction
SB 40 (State Business 40)	MP 191.69 Northbound (I-40 West Underpass - Structure 1128)	R17-6-406; R17-6-408	14' 9"		Over 12' - 16' = F/R	Coconino County Jurisdiction
SB 40 (State Business 40)	MP 191.69 Southbound (I-40 West Underpass - Structure 1128)	R17-6-406; R17-6-408	15' 8"		Over 12' - 16' = F/R	Coconino County Jurisdiction
SB 40 (State Business 40)	MP 191.69 (I-40 Underpass) to MP 195.96 (Railroad Underpass)	R17-6-406; R17-6-408			Over 12' - 16' = F/R	Coconino County Jurisdiction to MP 193.16
SB 40 (State Business 40)	MP 195.96 (Railroad Underpass)	R17-6-406; R17-6-408	13' 9"		Over 12' - 16' = F/R	
SB 40 (State Business 40)	MP 195.96 (Railroad Underpass) to MP 196.14 (Junction US 180)	R17-6-406; R17-6-408			Over 12' - 16' = F/R	
SB 40 (State Business 40)	MP 196.14 (Junction US 180) to MP 200.32 (Junction US 89)	R17-6-406; R17-6-408			Over 12' - 16' = F/R	City of Flagstaff from MP199.91
SB 40 (State Business 40)	MP 200.32 (Junction US 89) to MP 200.99 (Junction I-40)	R17-6-406; R17-6-408			Over 12' - 16' = F/R	City of Flagstaff
SB 40 (State Business 40)	MP 274.48 (West Joseph City) to MP 277.33 (East Joseph City)	R17-6-406; R17-6-408			Over 14' - 16' = F/R	
SB 40 (State Business 40)	MP 285.00 (West Holbrook) to MP 286.68 (Junction SR 77)	R17-6-406; R17-6-408			Over 14' - 16' = F/R	
SB 40 (State Business 40)	MP 286.68 (Junction SR 77) to MP 287.39 (Holbrook Middle I-40 Underpass)	R17-6-406; R17-6-408			Over 14' - 16' = F/R	
SB 40 (State Business 40)	287.39 (Holbrook Middle I-40 Underpass) to MP 289.80	R17-6-406; R17-6-408			Over 14' - 16' = F/R	
SB 40 (State Business 40)	MP 289.80 (East Holbrook, I-40 Underpass - Structure 1369)	R17-6-406; R17-6-408	14' 8"		Over 14' - 16' = F/R	
SB 79	MP 132.17 (Junction SR 79) to MP 134.03 (Junction SR 79)	R17-6-406; R17-6-408			Over 14' - 16' = F/R	
SR 51	MP 0.00 (Junctions I-10 and SR Loop 202) to MP 13.62 (Bell Road)	R17-6-404; R17-6-405; R17-6-406; R17-6-408; R17-6-409			Over 14' - 16' = R	
SR 51	MP 13.62 Northbound (Bell Road Underpass)	R17-6-404; R17-6-405; R17-6-406; R17-6-408; R17-6-409	15' 7"		Over 14' - 16' = R	

**ODPC Final Draft -  
(10/21/2011)**  
Not yet approved or proposed

Route	Restriction Location (MP = Mile Post)	Movement Subject to:	Height	Length	Width	Weight (in lbs)
<b>Escort requirements: F = front escort, R = rear escort, F/R = front and rear escort, and LE = law enforcement escort</b>						
SR 51	MP 13.62 Southbound (Bell Road Underpass)	R17-6-404; R17-6-405; R17-6-406; R17-6-408; R17-6-409	14' 10"		Over 14' - 16' = R	
SR 51	MP 13.62 (Bell Road) to MP 15.90 (Junction SR Loop 101)	R17-6-404; R17-6-405; R17-6-406; R17-6-408; R17-6-409			Over 14' - 16' = R	
SR 61	MP 352.88 (Junction US 60) to MP 381.86 (Junction US 180)	R17-6-406; R17-6-408			Over 12' - 16' = F/R	
SR 61	MP 416.49 (Junction US 191) to MP 430.26 (New Mexico State Line)	R17-6-406; R17-6-408			Over 10' - 16' = F/R	
SR 64	MP 185.46 (Junction I-40 in Williams) to MP 237.10 (Grand Canyon National Park)	R17-6-406; R17-6-408			Over 12' - 16' = F/R	
SR 64	MP 267.10 (Grand Canyon National Park) to MP 295.83 (Junction US 89)	R17-6-406; R17-6-408			Over 12' - 16' = F/R	
SR 66	MP 56.70 (Junction I-40) to MP 123.10 (Route end)	R17-6-406; R17-6-408			Over 14' - 16' = F/R	
SR 67	MP 579.36 (Junction US 89A) to MP 610.26 (North Rim)	R17-6-406; R17-6-408; Seasonal restriction Nov. 15 through May 15			Over 12' - 14' = F/R Over 14' - 16' = F/R + 2 LE	20,000
SR 68	MP 1.10 (Junction SR 95) to MP 27.10 (Junction US 93)	R17-6-405; R17-6-406; R17-6-408; R17-6-409			Over 14' - 16' = F/R	
SR 69	MP 262.20 (Junction I-17) to MP 296.00 (Junction SR 89)	R17-6-405; R17-6-406; R17-6-408; R17-6-409			Over 14' - 16' = F/R	
SR 71	MP 86.10 (Junction US 60) to MP 102.90 (SR 71 overpass)	R17-6-406; R17-6-408			Over 12' - 16' = F/R	
SR 71	MP 102.90 (SR 71 overpass)	R17-6-406; R17-6-408	14' 10"		Over 12' - 16' = F/R	
SR 71	MP 102.90 (SR 71 overpass) to MP 109.70 (Junction SR 89)	R17-6-406; R17-6-408			Over 12' - 16' = F/R	
SR 72	MP 13.10 (Junction SR 95) to MP 49.60 (Junction US 60)	R17-6-406; R17-6-408			Over 12' - 14' = F/R Over 14' - 16' = F/R + 2 LE	
SR 73	MP 310.40 (Junction US 60) to MP 334.72 (White River)	R17-6-406; R17-6-408			Over 10' - 14' = F/R Over 14' - 16' = F/R + 2 LE	
SR 73	MP 334.72 (White River) to MP 357.72 (Junction SR 260)	R17-6-406; R17-6-408			Over 14' - 16' = F/R	
SR 74	MP 0.00 (Junction US 60) to MP 30.84 (Junction I-17)	R17-6-406; R17-6-408			Over 14' - 16' = F/R	

**ODPC Final Draft -  
(10/21/2011)**  
Not yet approved or proposed

Route	Restriction Location (MP = Mile Post)	Movement Subject to:	Height	Length	Width	Weight (in lbs)
<b>Escort requirements: F = front escort, R = rear escort, F/R = front and rear escort, and LE = law enforcement escort</b>						
SR 75	MP 378.92 (Junction US 70) to MP 398.43 (Junction US 191)	R17-6-406; R17-6-408			Over 14' - 16' = F/R	
SR 77	MP 68.05 (Junction I-10 in Tucson) to MP 74.84 (Ina Road)	R17-6-404; R17-6-405; R17-6-406; R17-6-408; R17-6-409			Over 14' - 16' = F/R	
SR 77	MP 74.84 (Ina Road) to MP 79.48 (Tangerine Road)	R17-6-404; R17-6-405; R17-6-406; R17-6-408; R17-6-409			Over 14' - 16' = F/R	
SR 77	MP 79.48 (Tangerine Road) to MP 91.13 (Junction SR 79)	R17-6-406; R17-6-408			Over 14' - 16' = F/R	
SR 77	MP 91.13 (Junction SR 79) to MP 113.60 (Mammoth)	R17-6-406; R17-6-408			Over 14' - 16' = F/R	
SR 77	MP 113.60 (Mammoth) to MP 134.80 (Junction SR 177)	R17-6-406; R17-6-407; R17-6-408		80'+ unarticulated requires F/R; 110'+ articulated requires F/R	Over 12' - 14' = F/R Over 14' - 16' = F/R + 2 LE	
SR 77	MP 134.80 (Junction SR 177) to MP 170.90 (Junction US 70)	R17-6-406; R17-6-408		80'+ unarticulated requires F/R; 110'+ articulated requires F/R	Over 12' - 14' = F/R Over 14' - 16' = F/R + 2 LE	
SR 77	MP 342.20 (Junction US 60, Show Low) to MP 361.05 (Junction SR 277)	R17-6-406; R17-6-408			Over 12' - 16' = F/R	
SR 77	MP 361.05 (Junction SR 277) to MP 386.20 (Junction SR 377)	R17-6-406; R17-6-408			Over 12' - 16' = F/R	
SR 77	MP 386.20 (Junction SR 377) to MP 387.81 (Junction US 180)	R17-6-406; R17-6-408			Over 12' - 16' = F/R	
SR 77	MP 387.81 (Junction US 180) to MP 388.67 (Junction SB 40, Holbrook)	R17-6-406; R17-6-408			Over 12' - 16' = F/R	
SR 77	MP 395.05 (I-40 east of Holbrook) to MP 408.93 (End of State Route at Navajo Nation boundary)	R17-6-406; R17-6-408			Over 12' - 16' = F/R	
SR 78	MP 154.55 (Junctions SR 75 and US 191) to MP 174.73 (New Mexico State Line)	R17-6-406; R17-6-408			Over 12' - 14' = F/R Over 14' - 16' = F/R + 2 LE	
SR 79	MP 91.14 (Junction SR 77) to MP 132.17 (Junction SB 79)	R17-6-406; R17-6-408			Over 14' - 16' = F/R + 2 LE	
SR 79	MP 134.03 (Junction SB 79) to MP 150.28 (Junction US 60)	R17-6-406; R17-6-408			Over 14' - 16' = F/R	

**ODPC Final Draft -  
(10/21/2011)**  
Not yet approved or proposed

Route	Restriction Location (MP = Mile Post)	Movement Subject to:	Height	Length	Width	Weight (in lbs)
<b>Escort requirements: F = front escort, R = rear escort, F/R = front and rear escort, and LE = law enforcement escort</b>						
SR 80	MP 293.27 (Junction SB 10 in Benson) to MP 339.06 (Mule Pass tunnel)	R17-6-406; R17-6-408			Over 14' - 16' = F/R	
SR 80	MP 339.06 (Mule Pass tunnel)	R17-6-406; R17-6-408	14' 6"		Over 14' - 16' = F/R	
SR 80	MP 339.06 (Mule Pass tunnel) to MP 343.01 (Lowell Underpass)	R17-6-406; R17-6-408			Over 14' - 16' = F/R	
SR 80	MP 343.01 (Lowell Underpass)	R17-6-406; R17-6-408	14' 8"		Over 14' - 16' = F/R	
SR 80	MP 343.01 (Lowell Underpass) to MP 348.15 (Mulepass-Lowell Arch)	R17-6-406; R17-6-408			Over 14' - 16' = F/R	
SR 80	MP 348.15 (Mulepass-Lowell Arch - Structure 130)	R17-6-406; R17-6-408			Over 14' - 16' = F/R	Legal weight as provided under R17-6-102, Table 1.
SR 80	MP 348.15 (Mulepass-Lowell Arch) to MP 352.38 (Glance Creek Bridge)	R17-6-406; R17-6-408			Over 14' - 16' = F/R	
SR 80	MP 352.38 (Glance Creek Bridge - Structure 237)	R17-6-406; R17-6-408			Over 14' - 16' = F/R	Legal weight as provided under R17-6-102, Table 1.
SR 80	MP 352.38 (Glance Creek Bridge) to MP 364.66 (Douglas)	R17-6-406; R17-6-408			Over 14' - 16' = F/R	
SR 80	MP 364.66 (Douglas) to MP 366.12 (Junction US 191)	R17-6-406; R17-6-408			Over 12' - 16' = F/R	
SR 80	MP 366.12 (Junction US 191) to MP 415.39 (New Mexico State Line)	R17-6-406; R17-6-408			Over 12' - 16' = F/R	
SR 82	MP 0.00 (Junction SB 19) to MP 32.36 (Junction SR 83)	R17-6-406; R17-6-408			Over 12' - 14' = F/R Over 14' - 16' = F/R + 3 LE	
SR 82	MP 32.36 (Junction SR 83) to MP 51.59 (Junction SR 90)	R17-6-406; R17-6-408			Over 12' - 14' = F/R Over 14' - 16' = F/R + 3 LE	
SR 82	MP 51.59 (Junction SR 90) to MP 67.57 (Junction SR 80)	R17-6-406; R17-6-408			Over 12' - 14' = F/R Over 14' - 16' = F/R + 3 LE	
SR 83	MP 3.19 (Parker Canyon Lake) to MP 31.63 (Junction SR 82)	R17-6-406; R17-6-408			Over 10' - 14' = F/R Over 14' - 16' = F/R + 2 LE	
SR 83	MP 31.63 (Junction SR 82) to MP 58.00 (Junction I-10)	R17-6-406; R17-6-408			Over 12' - 14' = F/R Over 14' - 16' = F/R + 2 LE	
SR 84	MP 155.13 (Junction I-8) to MP 177.60 (Railroad Underpass)	R17-6-406; R17-6-408			Over 14' - 16' = F/R	
SR 84	MP 177.60 Eastbound (Railroad Underpass)	R17-6-406; R17-6-408	13' 5"		Over 14' - 16' = F/R	

**ODPC Final Draft -  
(10/21/2011)**  
Not yet approved or proposed

Route	Restriction Location (MP = Mile Post)	Movement Subject to:	Height	Length	Width	Weight (in lbs)
<b>Escort requirements: F = front escort, R = rear escort, F/R = front and rear escort, and LE = law enforcement escort</b>						
SR 84	MP 177.67 Westbound (Railroad Underpass)	R17-6-406; R17-6-408	14' 1"		Over 14' - 16' = F/R	
SR 84	MP 177.60 (Railroad Underpass) to MP 177.97 (Junctions SR 387 and SR 287)	R17-6-406; R17-6-408			Over 14' - 16' = F/R	
SR 85	MP 0.00 (Junction SB 8) to MP 0.35 (SR 85 overpass)	R17-6-406; R17-6-408			Over 14' - 16' = F/R + 2 LE	
SR 85	MP 0.35 (SR 85 overpass - Structure 702)	R17-6-406; R17-6-408	14' 5"		Over 14' - 16' = F/R + 2 LE	
SR 85	MP 0.35 (SR 85 overpass) to MP 0.37 (Railroad Underpass)	R17-6-406; R17-6-408			Over 14' - 16' = F/R + 2 LE	
SR 85	MP 0.37 (Railroad Underpass - Structure 734)	R17-6-406; R17-6-408	14' 5"		Over 14' - 16' = F/R + 2 LE	
SR 85	MP 0.37 (Railroad Underpass) to MP 0.60 (SR 85 overpass)	R17-6-406; R17-6-408			Over 14' - 16' = F/R + 2 LE	
SR 85	MP 0.60 Westbound (SR 85 overpass - Structure 1557)	R17-6-406; R17-6-408	14' 10"		Over 14' - 16' = F/R + 2 LE	
SR 85	MP 0.60 (SR 85 overpass) to MP 0.65 (SR 85 overpass)	R17-6-406; R17-6-408			Over 14' - 16' = F/R + 2 LE	
SR 85	MP 0.65 Eastbound (SR 85 overpass - Structure 1558)	R17-6-406; R17-6-408	14' 10"		Over 14' - 16' = F/R + 2 LE	
SR 85	MP 0.65 (SR 85 overpass) to MP 39.70 (Ajo)	R17-6-406; R17-6-408			Over 14' - 16' = F/R + 2 LE	
SR 85	MP 39.70 (Ajo) to MP 80.69 (US/Mexico Border)	R17-6-406; R17-6-408			Over 12' - 14' = F/R Over 14' - 16' = F/R + 2 LE	
SR 85	MP 120.31 (Junction SB 8) to MP 120.41 (SB 8 Underpass)	R17-6-405; R17-6-406; R17-6-408; R17-6-409			Over 14' - 16' = F/R	
SR 85	MP 120.41 Westbound (SB 8 Underpass)	R17-6-405; R17-6-406; R17-6-408; R17-6-409	15' 10"		Over 14' - 16' = F/R	
SR 85	MP 120.41 (SB 8 Underpass) to MP 154.48 (Junction I-10)	R17-6-405; R17-6-406; R17-6-408; R17-6-409			Over 14' - 16' = F/R	
SR 86	MP 53.00 (Junction SR 85) to MP 150.42 (Junction SR 286)	R17-6-406; R17-6-408			Over 12' - 14' = F/R Over 14' - 16' = F/R + 2 LE	
SR 86	MP 150.42 (Junction SR 286) to MP 164.04 (Camino Verde Road)	R17-6-406; R17-6-408			Over 14' - 16' = F/R	
SR 86	MP 164.04 (Camino Verde Road) to MP 171.44 (Junction I-19)	R17-6-404; R17-6-405; R17-6-406; R17-6-408; R17-6-409			Over 14' - 16' = F/R	

**ODPC Final Draft -  
(10/21/2011)**  
Not yet approved or proposed

Route	Restriction Location (MP = Mile Post)	Movement Subject to:	Height	Length	Width	Weight (in lbs)
<b>Escort requirements: F = front escort, R = rear escort, F/R = front and rear escort, and LE = law enforcement escort</b>						
SR 87	MP 115.20 (Junction I-10) to MP 115.20 (I-10 overpass)	R17-6-406; R17-6-408			Over 14' - 16' = F/R	
SR 87	MP 115.20 Northbound (I-10 overpass)	R17-6-406; R17-6-408	15' 3"		Over 14' - 16' = F/R	
SR 87	MP 115.20 Southbound (I-10 overpass)	R17-6-406; R17-6-408	15' 2"		Over 14' - 16' = F/R	
SR 87	MP 115.20 (Junction I-10) to MP 162.67 (Junction Ocotillo Road in Chandler)	R17-6-406; R17-6-408			Over 14' - 16' = F/R	
SR 87	MP 172.22 (Junction US 60) to MP 176.74 (Junction SR 202 overpass)	R17-6-405; R17-6-406; R17-6-408; R17-6-409			Over 14' - 16' = F/R	
SR 87	MP 176.74 (Junction SR 202 overpass)	R17-6-405; R17-6-406; R17-6-408; R17-6-409	15' 9"		Over 14' - 16' = F/R	
SR 87	MP 176.74 (Junction SR 202 overpass) to MP 252.50 (Junction SR 260, Payson)	R17-6-405; R17-6-406; R17-6-408; R17-6-409			Over 14' - 16' = F/R	
SR 87	MP 252.50 (Junction SR 260, Payson) to MP 278.80 (Junction SR 260)	R17-6-406; R17-6-407; R17-6-408		40' + requires F/R + 2 LE	Over 12' - 14' = F/R Over 14' - 16' = F/R + 2 LE	
SR 87	MP 278.80 (Junction SR 260) to MP 340.94 (Junction SR 99)	R17-6-406; R17-6-407; R17-6-408			Over 12' - 14' = F/R Over 14' - 16' = F/R + 3 LE	
SR 87	MP 340.94 (Junction SR 99) to MP 342.10 (Railroad Underpass, Winslow)	R17-6-406; R17-6-407; R17-6-408			Over 12' - 14' = F/R Over 14' - 16' = F/R + 3 LE	
SR 87	MP 342.10 (Railroad Underpass, Winslow - Structure 194)	R17-6-406; R17-6-407; R17-6-408	14' 6"		Over 12' - 14' = F/R Over 14' - 16' = F/R + 3 LE	
SR 87	MP 342.10 (Railroad Underpass, Winslow) to MP 342.23 (Junction SB 40)	R17-6-406; R17-6-407; R17-6-408			Over 12' - 14' = F/R Over 14' - 16' = F/R + 3 LE	
SR 87	MP 343.56 (SB 40 in Winslow) to MP 406.04 (Junction SR 264)	R17-6-406; R17-6-408			Over 12' - 14' = F/R Over 14' - 16' = F/R + 2 LE	
SR 88	MP 193.85 (Junction US 60) to MP 209.62 (First Water Creek Bridge)	R17-6-406; R17-6-408			Over 8' requires class C permit	
SR 88	MP 209.62 (First Water Creek Bridge - Structure 26)	R17-6-406; R17-6-408	14'	Over 40' requires class C permit	Over 8' requires class C permit	Legal weight as provided under R17-6-102, Table 1.
SR 88	MP 209.62 (First Water Creek Bridge) to MP 211.05 (Boulder Canyon Bridge)	R17-6-406; R17-6-408		Over 40' requires class C permit	Over 8' requires class C permit	20,000

**ODPC Final Draft -  
(10/21/2011)**

Not yet approved or proposed

Route	Restriction Location (MP = Mile Post)	Movement Subject to:	Height	Length	Width	Weight (in lbs)
<b>Escort requirements: F = front escort, R = rear escort, F/R = front and rear escort, and LE = law enforcement escort</b>						
SR 88	MP 211.05 (Boulder Canyon Bridge - Structure 193)	R17-6-406; R17-6-408		Over 40' requires class C permit	Over 8' requires class C permit	Legal weight as provided under R17-6-102, Table 1.
SR 88	MP 211.05 (Boulder Canyon Bridge) to MP 220.20 (End of pavement)	R17-6-406; R17-6-408		Over 40' requires class C permit	Over 8' requires class C permit	20,000
SR 88	MP 220.20 (End of pavement) to MP 222.00 (Fish Creek Hill)	R17-6-406; R17-6-408		Over 40' requires class C permit	Over 8' requires class C permit	20,000
SR 88	MP 222.00 (Fish Creek Hill) to MP 223.50 (Fish Creek Bridge)	R17-6-406; R17-6-408; One lane road		Over 40' requires class C permit	Over 8' requires class C permit	
SR 88	MP 223.50 (Fish Creek Bridge - Structure 27)	R17-6-406; R17-6-408; One lane bridge		Over 40' requires class C permit	Over 8' requires class C permit	Legal weight as provided under R17-6-102, Table 1.
SR 88	MP 223.50 (Fish Creek Bridge) to MP 224.40 (End of one lane road)	R17-6-406; R17-6-408		Over 40' requires class C permit	Over 8' requires class C permit	Legal weight as provided under R17-6-102, Table 1.
SR 88	MP 224.40 (End of one lane road) to MP 224.60 (Lewis Pranty Creek Bridge)	R17-6-406; R17-6-408		Over 40' requires class C permit	Over 8' requires class C permit	Legal weight as provided under R17-6-102, Table 1.
SR 88	MP 224.60 (Lewis Pranty Creek Bridge - Structure 28)	R17-6-406; R17-6-408		Over 40' requires class C permit	Over 8' requires class C permit	Legal weight as provided under R17-6-102, Table 1.
SR 88	MP 224.60 (Lewis Pranty Creek Bridge) to MP 225.55 (Dry Wash Bridge)	R17-6-406; R17-6-408		Over 40' requires class C permit	Over 8' requires class C permit	Legal weight as provided under R17-6-102, Table 1.
SR 88	MP 225.55 (Dry Wash Bridge - Structure 15)	R17-6-406; R17-6-408		Over 40' requires class C permit	Over 8' requires class C permit	Legal weight as provided under R17-6-102, Table 1.
SR 88	MP 225.55 (Dry Wash Bridge) to MP 226.60 (ADOT Maintenance Yard)	R17-6-406; R17-6-408		Over 40' requires class C permit	Over 8' requires class C permit	20,000
SR 88	MP 226.60 (ADOT Maintenance Yard) to MP 233.50 (Pine Creek Bridge)	R17-6-406; R17-6-408		Over 40' requires class C permit	Over 8' requires class C permit	Legal weight as provided under R17-6-102, Table 1.
SR 88	MP 233.50 (Pine Creek Bridge - Structure 31)	R17-6-406; R17-6-408		Over 40' requires class C permit	Over 8' requires class C permit	Legal weight as provided under R17-6-102, Table 1.
SR 88	MP 233.50 (Pine Creek Bridge) to MP 242.40 (Junction SR 188)	R17-6-406; R17-6-408		Over 40' requires class C permit	Over 8' requires class C permit	20,000
SR 89	MP 258.20 (Junction US 93) to MP 295.00 (Wilhoit)	R17-6-406; R17-6-408			Over 12' - 16' = F/R	
SR 89	MP 295.00 (Wilhoit) to MP 309.00 (Prescott City Limits)	R17-6-406; R17-6-408		Over 40' requires class C permit	Over 8' requires class C permit	
SR 89	MP 309.00 (Prescott City Limits) to MP 309.45 (Granite Creek Bridge #2)	R17-6-406; R17-6-408			Over 12' - 16' = F/R + 2 LE	
SR 89	MP 309.45 (Granite Creek Bridge #2 - Structure 106)	R17-6-406; R17-6-408			Over 12' - 16' = F/R + 2 LE	Legal weight as provided under R17-6-102, Table 1.

**ODPC Final Draft -  
(10/21/2011)**  
Not yet approved or proposed

Route	Restriction Location (MP = Mile Post)	Movement Subject to:	Height	Length	Width	Weight (in lbs)
<b>Escort requirements: F = front escort, R = rear escort, F/R = front and rear escort, and LE = law enforcement escort</b>						
SR 89	MP 309.45 (Granite Creek Bridge #2) to MP 320.00 (Willow Creek Road)	R17-6-406; R17-6-408			Over 12' - 14' = F/R Over 14' - 16' = F/R + 2 LE	
SR 89	MP 320.00 (Willow Creek Road) to MP 345.70 (Hell Canyon Bridge)	R17-6-406; R17-6-408			Over 12' - 14' = F/R Over 14' - 16' = F/R + 2 LE	
SR 89	MP 345.70 (Hell Canyon Bridge - Structure 483)	R17-6-406; R17-6-408			Over 12' - 14' = F/R Over 14' - 16' = F/R + 2 LE	Class A permitted vehicles with a gross weight of: 100,000 or less - no additional restrictions; 100,001 through 150,000 - drivers shall: Coordinate road closures by or under the direction of law enforcement; and Cross on center of bridge at a constant speed of no more than 10 mph while on bridge.  Class C permits and special analysis and approval from the ADOT Bridge Group are required for vehicles with a gross weight of 150,001 or more.
SR 89	345.70 (Hell Canyon Bridge) to MP 363.00 (Junction I-40)	R17-6-406; R17-6-408			Over 12' - 14' = F/R Over 14' - 16' = F/R + 2 LE	
SR 89A	MP 317.80 (Junction SR 89) to MP 331.00 (Old Fain Road)	R17-6-406; R17-6-408			Over 14' - 16' = F/R	
SR 89A	MP 331.00 (Old Fain Road) to MP 348.00 (Clarkdale)	R17-6-406; R17-6-408		Over 50' requires class C permit	Over 8' requires class C permit	
SR 89A	MP 348.00 (Clarkdale) to MP 355.21 (Junction SR 260)	R17-6-406; R17-6-408			Over 14' - 16' = F/R	
SR 89A	MP 355.21 (Junction SR 260) to MP 374.14 (Junction SR 179)	R17-6-406; R17-6-408			Over 14' - 16' = F/R	
SR 89A	MP 374.14 (Junction SR 179) to MP 375.66 (Midgley/Wilson Canyon Bridge)	R17-6-406; R17-6-408		Over 50' requires class C permit	Over 10' - 12' = F/R Over 12' - 16' = F/R + 2 LE	

**ODPC Final Draft -  
(10/21/2011)**  
Not yet approved or proposed

Route	Restriction Location (MP = Mile Post)	Movement Subject to:	Height	Length	Width	Weight (in lbs)
<b>Escort requirements: F = front escort, R = rear escort, F/R = front and rear escort, and LE = law enforcement escort</b>						
SR 89A	MP 375.66 (Midgley/Wilson Canyon Bridge - Structure 232)	R17-6-406; R17-6-408		Over 50' requires class C permit	Over 10' - 12' = F/R Over 12' - 16' = F/R + 2 LE	Class A permitted vehicles with a gross weight of: 100,000 or less - no additional restrictions; 100,001 through 150,000 - drivers shall: Coordinate road closures by or under the direction of law enforcement; and Cross on center of bridge at a constant speed of no more than 10 mph while on bridge.  Class C permits and special analysis and approval from the ADOT Bridge Group are required for vehicles with a gross weight of 150,001 or more.
SR 89A	MP 375.66 (Midgley/Wilson Canyon Bridge) to MP 398.96 (JW Powell Boulevard/I-17)	R17-6-406; R17-6-408		Over 50' requires class C permit	Over 10' - 12' = F/R Over 12' - 16' = F/R + 2 LE	
SR 90	MP 289.59 Eastbound (SR 90 Overpass - Structure 963C)	R17-6-405; R17-6-406; R17-6-408; R17-6-409	15'		Over 14' - 16' = F/R	
SR 90	MP 289.59 Eastbound (SR 90 Overpass - Structure 962C)	R17-6-405; R17-6-406; R17-6-408; R17-6-409	15'		Over 14' - 16' = F/R	
SR 90	MP 289.59 (Junction I-10) to MP 308.39 (Junction SR 82)	R17-6-405; R17-6-406; R17-6-408; R17-6-409			Over 14' - 16' = F/R	
SR 90	MP 308.39 (Junction SR 82) to MP 321.52 (Junction SR 92)	R17-6-405; R17-6-406; R17-6-408; R17-6-409			Over 14' - 16' = F/R	
SR 90	MP 321.52 (Junction SR 92) to MP 328.64 (San Pedro River bridge)	R17-6-405; R17-6-406; R17-6-408; R17-6-409			Over 14' - 16' = F/R	
SR 90	MP 328.64 (San Pedro River bridge - Structure 425)	R17-6-405; R17-6-406; R17-6-408; R17-6-409			Over 14' - 16' = F/R	Legal weight as provided under R17-6-102, Table 1.
SR 90	MP 328.64 (San Pedro River bridge) to MP 336.40 (Junction SR 80)	R17-6-405; R17-6-406; R17-6-408; R17-6-409			Over 14' - 16' = F/R	
SR 92	MP 321.00 (Junction SR 90) to MP 340.56 (San Pedro River bridge)	R17-6-406; R17-6-408			Over 14' - 16' = F/R	

**ODPC Final Draft -  
(10/21/2011)**  
Not yet approved or proposed

Route	Restriction Location (MP = Mile Post)	Movement Subject to:	Height	Length	Width	Weight (in lbs)
<b>Escort requirements: F = front escort, R = rear escort, F/R = front and rear escort, and LE = law enforcement escort</b>						
SR 92	MP 340.56 (San Pedro River bridge - Structure 449)	R17-6-406; R17-6-408			Over 14' - 16' = F/R + 2 LE	Class A permitted vehicles with a gross weight of: 100,000 or less - no additional restrictions; 100,001 through 150,000 - drivers shall: Coordinate road closures by or under the direction of law enforcement; and Cross on center of bridge at a constant speed of no more than 10 mph while on bridge.  Class C permits and special analysis and approval from the ADOT Bridge Group are required for vehicles with a gross weight of 150,001 or more.
SR 92	MP 340.56 (San Pedro River bridge) to MP 355.00 (Junction SR 80)	R17-6-406; R17-6-408			Over 14' - 16' = F/R	
SR 95	MP 109.04 (at SB 10 in Quartzsite) to MP 131.68 (Junction SR 72)	R17-6-406; R17-6-408			Over 14' - 16' = F/R	
SR 95	MP 131.68 (Junction SR 72) to MP 143.93 (Junction SR 95 Spur)	R17-6-406; R17-6-408			Over 14' - 16' = F/R	
SR 95	MP 143.93 (Junction SR 95 Spur) to MP 144.75 (Airport Road in Parker)	R17-6-406; R17-6-408			Over 14' - 16' = F/R	
SR 95	MP 144.75 (Airport Road in Parker) to MP 187.51 (Chenowith Drive in Lake Havasu City)	R17-6-406; R17-6-408			Over 14' - 16' = F/R	
SR 95	MP 187.51 (Chenowith Drive in Lake Havasu City) to MP 202.06 (Junction I- 40)	R17-6-406; R17-6-408			Over 14' - 16' = F/R	
SR 95	MP 226.08 (California State Line near Needles) to MP 227.32 (Courtwright Road)	R17-6-406; R17-6-408			Over 12' - 16' = F/R	
SR 95	MP 227.32 (Courtwright Road) to MP 249.80 (Junction SR 68)	R17-6-405; R17-6-406; R17-6-408; R17-6-409			Over 14' - 16' = F/R	
SR 95 Spur	MP 144.83 (Colorado River Bridge - Structure 191)	California issues permit			Over 14' - 16' = F/R	Legal weight as provided under R17-6-102, Table 1.
SR 96	MP 0.00 (Bagdad) to MP 4.01 (Junction SR 97)	R17-6-406; R17-6-408			Over 10' - 14' = F/R Over 14' - 16' = F/R + 2 LE	
SR 96	MP 4.01 (Junction SR 97) to MP 10.80 (Santa Maria River Bridge)	R17-6-406; R17-6-408			Over 10' - 14' = F/R Over 14' - 16' = F/R + 2 LE	

**ODPC Final Draft -  
(10/21/2011)**  
Not yet approved or proposed

Route	Restriction Location (MP = Mile Post)	Movement Subject to:	Height	Length	Width	Weight (in lbs)
<b>Escort requirements: F = front escort, R = rear escort, F/R = front and rear escort, and LE = law enforcement escort</b>						
SR 96	MP 10.80 (Santa Maria River Bridge - Structure 225)	R17-6-406; R17-6-408			Over 10' - 14' = F/R Over 14' - 16' = F/R + 2 LE	Class A permitted vehicles with a gross weight of: 100,000 or less - no additional restrictions; 100,001 through 150,000 - drivers shall: Coordinate road closures by or under the direction of law enforcement; and Cross on center of bridge at a constant speed of no more than 10 mph while on bridge.  Class C permits and special analysis and approval from the ADOT Bridge Group are required for vehicles with a gross weight of 150,001 or more.
SR 96	MP 10.80 (Santa Maria River Bridge) to MP 21.92 (Town of Hillside)	R17-6-406; R17-6-408			Over 10' - 14' = F/R Over 14' - 16' = F/R + 2 LE	
SR 97	MP 155.52 (Junction US 93) to MP 166.97 (Junction SR 96)	R17-6-406; R17-6-408			Over 12' - 14' = F/R Over 14' - 16' = F/R + 2 LE	
SR 98	MP 294.67 (Junction US 89) to MP 361.39 (Electrical wire near Junction US 160)	R17-6-406; R17-6-408			Over 14' - 16' = F/R	
SR 98	MP 361.39 (Electrical wire near Junction US 160)	R17-6-406; R17-6-408	16' 6"		Over 14' - 16' = F/R	
SR 98	MP 361.39 (Electrical wire near Junction US 160) to MP 361.56 (Junction US 160)	R17-6-406; R17-6-408			Over 14' - 16' = F/R	
SR 99	MP 27.5 (Beginning of route south of Winslow) to MP 38.19 (Clear Creek Arch Bridge)	R17-6-406; R17-6-408			Over 14' - 16' = F/R + 2 LE	
SR 99	MP 38.19 (Clear Creek Arch Bridge - Structure 1038)	R17-6-406; R17-6-408			Over 14' - 16' = F/R + 2 LE	Legal weight as provided under R17-6-102, Table 1.
SR 99	MP 38.19 (Clear Creek Arch Bridge) to MP 38.90 (Jacks Canyon Bridge)	R17-6-406; R17-6-408			Over 14' - 16' = F/R + 2 LE	
SR 99	MP 38.90 (Jacks Canyon Bridge - Structure 1036)	R17-6-406; R17-6-408			Over 14' - 16' = F/R + 2 LE	Legal weight as provided under R17-6-102, Table 1.
SR 99	MP 38.90 (Jacks Canyon Bridge) to MP 42.65 (Junction SR 87)	R17-6-406; R17-6-408			Over 14' - 16' = F/R + 2 LE	
SR 99	MP 52.69 (Junction I-40) to MP 72.16 (Route end at BIA 15)	R17-6-406; R17-6-408			Over 14' - 16' = F/R + 2 LE	

**ODPC Final Draft -  
(10/21/2011)**  
Not yet approved or proposed

Route	Restriction Location (MP = Mile Post)	Movement Subject to:	Height	Length	Width	Weight (in lbs)
<b>Escort requirements: F = front escort, R = rear escort, F/R = front and rear escort, and LE = law enforcement escort</b>						
SR 101	MP 1.21 (Junction I-10, near 99th Avenue) to MP 56.60 (Guadalupe Road TI)	R17-6-404; R17-6-405; R17-6-406; R17-6-408; R17-6-409			Over 14' - 16' = R	
SR 101	MP 56.60 (Guadalupe Road Underpass - Structure 2283)	R17-6-404; R17-6-405; R17-6-406; R17-6-408; R17-6-409	15' 8"		Over 14' - 16' = R	
SR 101	MP 56.60 (Guadalupe Road TI) to MP 57.09 (Lateral 9.5 Canal)	R17-6-404; R17-6-405; R17-6-406; R17-6-408; R17-6-409			Over 14' - 16' = R	
SR 101	MP 57.09 Southbound (Lateral 9.5 Canal Underpass - Structure 2522)	R17-6-404; R17-6-405; R17-6-406; R17-6-408; R17-6-409	15' 4"		Over 14' - 16' = R	
SR 101	MP 57.09 (Lateral 9.5 Canal) to MP 61.33 (Junction SR 202)	R17-6-404; R17-6-405; R17-6-406; R17-6-408; R17-6-409			Over 14' - 16' = R	
SR 143	MP 0.00 (Junction I-10) to MP 3.81 (McDowell Road)	R17-6-404; R17-6-405; R17-6-406; R17-6-408; R17-6-409			Over 14' - 16' = R	
SR 169	MP 0.00 (Junction SR 69) to MP 15.10 (Junction I-17)	R17-6-406; R17-6-408			Over 14' - 16' = F/R	
SR 177	MP 136.31 (Junction SR 77) to MP 167.64 (Junction US 60)	R17-6-406; R17-6-408			Over 12' - 14' = F/R Over 14' - 16' = F/R + 2 LE	
SR 179	MP 298.95 (Junction I-17)	R17-6-406; R17-6-408			Over 12' - 16' = F/R	
SR 179	MP 298.95 (Sedona Road overpass - Structure 633)	R17-6-406; R17-6-408	14' 2"		Over 12' - 16' = F/R	
SR 179	MP 298.95 (Sedona Road overpass - Structure 1061)	R17-6-406; R17-6-408	14' 2"		Over 12' - 16' = F/R	
SR 179	MP 298.95 (Junction I-17) to MP 313.44 (Junction SR 89A)	R17-6-406; R17-6-408			Over 12' - 16' = F/R	
SR 180A	MP 343.10 (Junction US 180) to MP 353.00 (Junction SR 61)	R17-6-406; R17-6-408			Over 14' requires class C permit	
SR 181	MP 38.25 (Junction US 191) to MP 61.08 (Junction SR 186)	R17-6-406; R17-6-408			Over 12' - 14' = F/R Over 14' - 16' = F/R + 2 LE	
SR 181	MP 61.08 (Junction SR 186) to MP 65.04 (Chiricahua National Monument)	R17-6-406; R17-6-408			Over 12' - 14' = F/R Over 14' - 16' = F/R + 2 LE	

**ODPC Final Draft -  
(10/21/2011)**  
Not yet approved or proposed

Route	Restriction Location (MP = Mile Post)	Movement Subject to:	Height	Length	Width	Weight (in lbs)
<b>Escort requirements: F = front escort, R = rear escort, F/R = front and rear escort, and LE = law enforcement escort</b>						
SR 186	MP 326.19 (Junction I-10 in Willcox) to MP 359.42 (Junction SR 181)	R17-6-406; R17-6-408			Over 10' - 14' = F/R Over 14' - 16' = F/R + 2 LE	
SR 187	MP 186.77 (Junction SR 387) to MP 192.19 (Junction SR 87)	R17-6-406; R17-6-408			Over 14' - 16' = F/R	
SR 188	MP 214.92 (Junction US 60) to MP 229.58 (Junction SR 288)	R17-6-406; R17-6-408			Over 14' - 16' = F/R	
SR 188	MP 229.58 (Junction SR 288) to MP 244.15 (Junction SR 88)	R17-6-406; R17-6-408			Over 14' - 16' = F/R	
SR 188	MP 244.15 (Junction SR 88) to MP 244.28 (Roosevelt Lake Bridge)	R17-6-406; R17-6-408			Over 14' - 16' = F/R	
SR 188	MP 244.28 (Roosevelt Lake Bridge - Structure 2028)	R17-6-406; R17-6-408			Over 14' - 16' = F/R + 2 LE	Class A permitted vehicles with a gross weight of: 150,000 or less - no additional restrictions; 150,001 through 250,000 - drivers shall: Coordinate road closures by or under the direction of law enforcement; and Cross on center of bridge at a constant speed of no more than 10 mph while on bridge.  Class C permitted vehicles with a gross weight of over 250,000 require special analysis and approval from the ADOT Bridge Group.
SR 188	MP 244.28 (Roosevelt Lake Bridge) to MP 250.00 (Rock Creek)	R17-6-406; R17-6-408			Over 14' - 16' = F/R	
SR 188	MP 250.00 (Rock Creek) to MP 260.00 (South of Punkin Center)	R17-6-406; R17-6-408			Over 14' - 16' = F/R	
SR 188	MP 260.00 (South of Punkin Center) to MP 276.78 (Junction SR 87)	R17-6-406; R17-6-408			Over 14' - 16' = F/R	
SR 189	MP 0.00 (US/Mexico Border) to MP 2.88 (Junction I-19)	R17-6-406; R17-6-408			Over 14' - 16' = F/R	
SR 189	MP 2.88 (Junction I-19) to MP 3.75 (Junction SB 19)	R17-6-406; R17-6-408			Over 14' - 16' = F/R	
SR 195	MP 2.50 (Begin route at Avenue E 1/2) to MP 24.39 (Junction I-8)	R17-6-406; R17-6-408			Over 14' - 16' = F/R	
SR 202	MP 0.00 (Junctions I-10 and SR 51) to MP 9.80 (Junction SR 101)	R17-6-404; R17-6-405; R17-6-406; R17-6-408; R17-6-409			Over 14' - 16' = R	
SR 202	MP 9.80 (Junction SR 101) to MP 57.24 (Junction I-10)	R17-6-404; R17-6-405; R17-6-406; R17-6-408; R17-6-409			Over 14' - 16' = R	

**ODPC Final Draft -  
(10/21/2011)**  
Not yet approved or proposed

Route	Restriction Location (MP = Mile Post)	Movement Subject to:	Height	Length	Width	Weight (in lbs)
<b>Escort requirements: F = front escort, R = rear escort, F/R = front and rear escort, and LE = law enforcement escort</b>						
SR 238	MP 24.00 to MP 44.25 (Junction SR 347)	R17-6-406; R17-6-408			Over 14' - 16' = F/R	
SR 260	MP 206.40 (Junction SR 89A) to MP 218.60 (Junction I-17)	R17-6-406; R17-6-408			Over 14' - 16' = F/R	
SR 260	MP 218.60 (Junction I-17) to MP 252.00 (Junction SR 87)	R17-6-406; R17-6-408			Over 14' - 16' = F/R	
SR 260	MP 252.00 (Junction SR 87 in Payson) to MP 256.00 (Star Valley)	R17-6-405; R17-6-406; R17-6-408; R17-6-409			Over 14' - 16' = F/R	
SR 260	MP 256.00 (Star Valley) to MP 305.67 (Junction SR 277)	R17-6-406; R17-6-407; R17-6-408			Over 12' - 14' = F/R Over 14' - 16' = F/R + 2 LE	
SR 260	MP 305.67 (Junction SR 277) to MP 340.07 (Junction US 60 in Show Low)	R17-6-406; R17-6-408			Over 12' - 14' = F/R Over 14' - 16' = F/R + 2 LE	
SR 260	MP 341.68 (Junction US 60 in East Show Low) to MP 357.72 (Junction SR 73)	R17-6-406; R17-6-408			Over 14' - 16' = F/R	
SR 260	MP 357.72 (Junction SR 73) to MP 368.60 (Junction SR 473, Hawley Lake Road)	R17-6-406; R17-6-408		80'+ requires F/R	Over 12' - 16' = F/R	
SR 260	MP 368.60 (Junction SR 473, Hawley Lake Road) to MP 377.44 (Junction SR 273)	R17-6-406; R17-6-408		80'+ requires F/R	Over 12' - 16' = F/R	
SR 260	MP 377.44 (Junction SR 273) to MP 385.56 (Junction SR 373, Greer)	R17-6-406; R17-6-408		80'+ requires F/R	Over 12' - 16' = F/R	
SR 260	MP 385.56 (Junction SR 373, Greer) to MP 393.01 (Junction SR 261, Big Lake)	R17-6-406; R17-6-408		80'+ requires F/R	Over 12' - 16' = F/R	
SR 260	MP 393.01 (Junction SR 261, Big Lake) to MP 398.67 (Junction US 180)	R17-6-406; R17-6-408		80'+ requires F/R	Over 12' - 16' = F/R	
SR 261	MP 394.37 (Junction SR 273) to MP 412.50 (Junction SR 260)	R17-6-406; R17-6-408			Over 8' requires class C permit	35,000
SR 264	MP 321.97 (Junction US 160) to MP 384.23 (Junction SR 87)	R17-6-406; R17-6-408			Over 12' - 14' = F/R Over 14' - 16' = F/R + 2 LE	
SR 264	MP 384.23 (Junction SR 87) to MP 441.02 (Junction US 191)	R17-6-406; R17-6-408			Over 12' - 14' = F/R Over 14' - 16' = F/R + 2 LE	

**ODPC Final Draft -  
(10/21/2011)**  
Not yet approved or proposed

Route	Restriction Location (MP = Mile Post)	Movement Subject to:	Height	Length	Width	Weight (in lbs)
<b>Escort requirements: F = front escort, R = rear escort, F/R = front and rear escort, and LE = law enforcement escort</b>						
SR 264	MP 441.02 (Junction US 191) to MP 446.87 (Junction US 191)	R17-6-406; R17-6-408			Over 12' - 14' = F/R Over 14' - 16' = F/R + 2 LE	
SR 264	MP 446.87 (Junction US 191) to MP 476.12 (New Mexico State Line)	R17-6-406; R17-6-408			Over 12' - 16' = F/R	
SR 266	MP 104.60 (Junction US 191) to MP 123.80 (Bonita)	R17-6-406; R17-6-408			Over 12' - 16' = F/R	
SR 273	MP 377.46 (Junction SR 260) to MP 394.31 (Junction SR 261)	R17-6-406; R17-6-408		80'+ requires F/R	Over 10' - 16' = F/R	20,000
SR 273	MP 394.31 (Junction SR 261) to MP 396.83 (Big Lake)	R17-6-406; R17-6-408		80'+ requires F/R	Over 10' - 16' = F/R	20,000
SR 277	MP 305.67 (Junction SR 260) to MP 312.62 (Junction SR 377)	R17-6-406; R17-6-408			Over 12' - 14' = F/R Over 14' - 16' = F/R + 2 LE	
SR 277	MP 312.62 (Junction SR 377) to MP 321.20 (Junction SR 277 Spur)	R17-6-406; R17-6-408			Over 12' - 14' = F/R Over 14' - 16' = F/R + 2 LE	
SR 277	MP 321.20 (Junction SR 277 Spur) to MP 336.45 (Junction SR 77)	R17-6-406; R17-6-408			Over 12' - 14' = F/R Over 14' - 16' = F/R + 2 LE	
SR 286	MP 0.00 (US/Mexico Border) to MP 45.48 (Junction SR 86)	R17-6-406; R17-6-408			Over 12' - 14' = F/R Over 14' - 16' = F/R + 2 LE	
SR 287	MP 111.72 (Junction SR 387) to MP 115.84 (Junction I-10)	R17-6-406; R17-6-408			Over 14' - 16' = F/R	
SR 287	MP 115.84 (Junction I-10) to MP 125.81 (Junction SR 87)	R17-6-406; R17-6-408			Over 14' - 16' = F/R	
SR 287	MP 134.75 (Junction SR 87) to MP 142.96 (Junction SB 79)	R17-6-406; R17-6-408			Over 14' - 16' = F/R	
SR 288	MP 258.10 (Junction SR 188) to MP 262.44 (Salt River Bridge)	R17-6-406; R17-6-408		70'+ requires F/R	Over 8' requires class C permit	
SR 288	MP 262.44 (Salt River Bridge - Structure 37)	R17-6-406; R17-6-408	12'	70'+ requires F/R	Over 8' requires class C permit	Legal weight as provided under R17-6-102, Table 1.
SR 288	MP 262.44 (Salt River Bridge) to MP 311.90 (Route end near Young)	R17-6-406; R17-6-408		70'+ requires F/R	Over 8' requires class C permit	
SR 289	MP 0.00 (Junction I-19) to MP 10.83 (Route end)	R17-6-406; R17-6-408			Over 10' - 14' = F/R Over 14' - 16' = F/R + 2 LE	

**ODPC Final Draft -  
(10/21/2011)**  
Not yet approved or proposed

Route	Restriction Location (MP = Mile Post)	Movement Subject to:	Height	Length	Width	Weight (in lbs)
<b>Escort requirements: F = front escort, R = rear escort, F/R = front and rear escort, and LE = law enforcement escort</b>						
SR 303	MP 3.87 (Junction I-10) to MP 19.23 (Junction US 60, Grand Avenue)	R17-6-406; R17-6-408			Over 14' - 16' = F/R + 2 LE	
SR 303	MP 19.23 (Junction US 60, Grand Avenue) to MP 25.65 (Temporary route end at Happy Valley Road)	R17-6-406; R17-6-408			Over 14' - 16' = F/R + 2 LE	
SR 347	MP 160.89 (Junction SR 84) to MP 174.55 (Junction SR 238)	R17-6-405; R17-6-406; R17-6-408; R17-6-409			Over 14' - 16' = F/R	
SR 347	MP 174.55 (Junction SR 238) to MP 189.31 (Junction I-10)	R17-6-405; R17-6-406; R17-6-408; R17-6-409			Over 14' - 16' = F/R	
SR 366	MP 113.69 (Junction US 191) to MP 143.20 (Route end)	R17-6-406; R17-6-408		Over 40' requires class C permit	Over 8' requires class C permit	
SR 373	MP 385.65 (Junction SR 260) to MP 390.21 (End of route at Greer)	R17-6-406; R17-6-408		80'+ requires F/R	Over 12' - 16' = F/R	
SR 377	MP 0.00 (Junction SR 277) to MP 33.83 (Junction SR 77)	R17-6-406; R17-6-408			Over 12' - 14' = F/R Over 14' - 16' = F/R + 2 LE	
SR 386	MP 0.00 (Junction SR 86) to MP 12.05 (Kitt Peak)	R17-6-406; R17-6-408			Over 10' - 14' = F/R Over 14' - 16' = F/R + 2 LE	
SR 387	MP 0.00 (Junctions SR 84 and SR 287) to MP 8.42 (Junction I-10)	R17-6-406; R17-6-408			Over 14' - 16' = F/R	
SR 387	MP 8.42 (Junction I-10) to MP 15.72 (Junction SR 87)	R17-6-406; R17-6-408			Over 14' - 16' = F/R	
SR 389	MP 0.00 (Utah State Line) to MP 32.60 (Junction US 89A)	R17-6-406; R17-6-408			Over 14' - 16' = F/R	
SR 473	MP 0.00 (Junction SR 260) to MP 10.03 (Route end at Hawley Lake)	R17-6-406; R17-6-408		60'+ requires F/R	Over 10' - 14' = F/R Over 14' requires class C permit	20,000
SR 564	MP 374.28 (Junction US 160) to MP 383.46 (Route end)	R17-6-406; R17-6-408			Over 12' - 14' = F/R Over 14' requires class C permit	
SR 587	MP 218.74 (Junction SR 87) to MP 225.14 (Junction I-10)	R17-6-406; R17-6-408			Over 14' - 16' = F/R	
US 60	MP 31.20 (Junction I-10) to MP 49.52 (Junction SR 72)	R17-6-406; R17-6-408			Over 14' - 16' = F/R	
US 60	MP 49.52 (Junction SR 72) to MP 85.91 (Junction SR 71)	R17-6-406; R17-6-408			Over 14' - 16' = F/R	
US 60	MP 85.91 (Junction SR 71) to MP 107.7 (Vulture Mine Road)	R17-6-406; R17-6-408			Over 14' - 16' = F/R	

**ODPC Final Draft -  
(10/21/2011)**  
Not yet approved or proposed

Route	Restriction Location (MP = Mile Post)	Movement Subject to:	Height	Length	Width	Weight (in lbs)
<b>Escort requirements: F = front escort, R = rear escort, F/R = front and rear escort, and LE = law enforcement escort</b>						
US 60	MP 107.7 (Vulture Mine Road) to MP 110.24 (Railroad Underpass)	R17-6-405; R17-6-406; R17-6-408; R17-6-409			Over 14' - 16' = F/R	
US 60	MP 110.24 Eastbound (Washington Street Underpass, Wickenburg - Structure 535)	R17-6-405; R17-6-406; R17-6-408; R17-6-409	13' 11"		Over 14' - 16' = F/R	
US 60	MP 110.24 Westbound (Washington Street Underpass)	R17-6-405; R17-6-406; R17-6-408; R17-6-409	13' 7"		Over 14' - 16' = F/R	
US 60	MP 110.25 Eastbound (Railroad Underpass, Wickenburg)	R17-6-405; R17-6-406; R17-6-408; R17-6-409	13' 11'		Over 14' - 16' = F/R	
US 60	MP 110.25 Westbound (Railroad Underpass)	R17-6-405; R17-6-406; R17-6-408; R17-6-409	13' 7"		Over 14' - 16' = F/R	
US 60	MP 110.26 Eastbound (Frontier Street Underpass)	R17-6-405; R17-6-406; R17-6-408; R17-6-409	13' 11"		Over 14' - 16' = F/R	
US 60	MP 110.26 Westbound (Frontier Street Underpass, Wickenburg - Structure 1000)	R17-6-405; R17-6-406; R17-6-408; R17-6-409	13' 7"		Over 14' - 16' = F/R	
US 60	MP 110.26 (frontier) to MP 110.33 (Junction US 93)	R17-6-405; R17-6-406; R17-6-408; R17-6-409			Over 14' - 16' = F/R	
US 60	MP 110.33 (Junction US 93) to MP 138.48 (Junction SR 303)	R17-6-405; R17-6-406; R17-6-408; R17-6-409			Over 14' - 16' = F/R	
US 60	MP 138.48 (Junction SR 303) to MP 148.90 (Junction SR 101)	R17-6-405; R17-6-406; R17-6-408; R17-6-409			Over 14' - 16' = F/R	
US 60	MP 148.90 (Junction SR 101) to MP 160.10 (Junction I-17)	R17-6-405; R17-6-406; R17-6-408; R17-6-409			Over 14' - 16' = F/R	
US 60	MP 172.00 (Junction I-10) to MP 172.90 (Hardy Drive)	R17-6-404; R17-6-405; R17-6-406; R17-6-408; R17-6-409			Over 14' - 16' = R	
US 60	MP 172.90 Eastbound (Hardy Drive)	R17-6-404; R17-6-405; R17-6-406; R17-6-408; R17-6-409	15' 6"		Over 14' - 16' = R	
US 60	MP 172.90 Westbound (Hardy Drive)	R17-6-404; R17-6-405; R17-6-406; R17-6-408; R17-6-409	15' 3"		Over 14' - 16' = R	
US 60	MP 172.90 (Hardy Drive) to MP 174.41 (Rural Road TI)	R17-6-404; R17-6-405; R17-6-406; R17-6-408; R17-6-409			Over 14' - 16' = R	
US 60	MP 174.41 Eastbound (Rural Road Underpass - Structure 2640)	R17-6-404; R17-6-405; R17-6-406; R17-6-408; R17-6-409	15' 10"		Over 14' - 16' = R	

**ODPC Final Draft -  
(10/21/2011)**  
Not yet approved or proposed

Route	Restriction Location (MP = Mile Post)	Movement Subject to:	Height	Length	Width	Weight (in lbs)
<b>Escort requirements: F = front escort, R = rear escort, F/R = front and rear escort, and LE = law enforcement escort</b>						
US 60	MP 174.41 (Rural Road TI) to MP 175.42 (McClintock Drive)	R17-6-404; R17-6-405; R17-6-406; R17-6-408; R17-6-409			Over 14' - 16' = R	
US 60	MP 175.42 Eastbound (McClintock Drive)	R17-6-404; R17-6-405; R17-6-406; R17-6-408; R17-6-409	15' 10"		Over 14' - 16' = R	
US 60	MP 175.42 Westbound (McClintock Drive)	R17-6-404; R17-6-405; R17-6-406; R17-6-408; R17-6-409	15' 11"		Over 14' - 16' = R	
US 60	MP 175.42 (McClintock Drive) to MP 176.29 (Junction SR 101)	R17-6-404; R17-6-405; R17-6-406; R17-6-408; R17-6-409			Over 14' - 16' = R	
US 60	MP 176.29 (Junction SR 101) to MP 176.49 (SB 101 Over US 60)	R17-6-404; R17-6-405; R17-6-406; R17-6-408; R17-6-409			Over 14' - 16' = R	
US 60	MP 176.49 Eastbound (SB 101 Over US 60 - Structures 1792, 1791, & 2101)	R17-6-404; R17-6-405; R17-6-406; R17-6-408; R17-6-409	15' 8"		Over 14' - 16' = R	
US 60	MP 176.49 Westbound (SB 101 Over US 60 - Structures 1792, 1791, & 2101)	R17-6-404; R17-6-405; R17-6-406; R17-6-408; R17-6-409	15' 9"		Over 14' - 16' = R	
US 60	MP 176.49 (SB 101 Over US 60) to MP 177.45 (Dobson Road)	R17-6-404; R17-6-405; R17-6-406; R17-6-408; R17-6-409			Over 14' - 16' = R	
US 60	MP 177.45 (Dobson Road - Structure 1795)	R17-6-404; R17-6-405; R17-6-406; R17-6-408; R17-6-409	15' 9"		Over 14' - 16' = R	
US 60	MP 177.45 (Dobson Road) to MP 184.39 (Val Vista Drive TI)	R17-6-404; R17-6-405; R17-6-406; R17-6-408; R17-6-409			Over 14' - 16' = R	
US 60	MP 184.39 (Val Vista Drive Underpass - Structure 1883)	R17-6-404; R17-6-405; R17-6-406; R17-6-408; R17-6-409	15' 11"		Over 14' - 16' = R	
US 60	MP 184.39 (Val Vista Drive TI) to MP 184.77 (39th Street)	R17-6-404; R17-6-405; R17-6-406; R17-6-408; R17-6-409			Over 14' - 16' = R	
US 60	MP 184.77 (39th Street Underpass - Structure 1918)	R17-6-404; R17-6-405; R17-6-406; R17-6-408; R17-6-409	15' 11"		Over 14' - 16' = R	

**ODPC Final Draft -  
(10/21/2011)**  
Not yet approved or proposed

Route	Restriction Location (MP = Mile Post)	Movement Subject to:	Height	Length	Width	Weight (in lbs)
<b>Escort requirements: F = front escort, R = rear escort, F/R = front and rear escort, and LE = law enforcement escort</b>						
US 60	MP 184.77 (39th Street) to MP 188.38 (Power Road)	R17-6-404; R17-6-405; R17-6-406; R17-6-408; R17-6-409			Over 14' - 16' = R	
US 60	MP 188.38 (Power Road - Structure 1924)	R17-6-404; R17-6-405; R17-6-406; R17-6-408; R17-6-409	15' 9"		Over 14' - 16' = R	
US 60	MP 188.38 (Power Road) to MP 190.51 (Junction SR 202)	R17-6-404; R17-6-405; R17-6-406; R17-6-408; R17-6-409			Over 14' - 16' = R	
US 60	MP 190.51 (Junction SR 202) to MP 194.38 (Meridian Road)	R17-6-405; R17-6-406; R17-6-408; R17-6-409			Over 14' - 16' = R	
US 60	MP 194.38 Eastbound (Meridian Road Underpass - Structure 1438)	R17-6-405; R17-6-406; R17-6-408; R17-6-409	15' 10"		Over 14' - 16' = R	
US 60	MP 194.38 Westbound (Meridian Road Underpass - Structure 1438)	R17-6-405; R17-6-406; R17-6-408; R17-6-409	15' 9"		Over 14' - 16' = R	
US 60	MP 194.38 (Meridian Road) to MP 196.14 (Junction SR 88, Idaho Road)	R17-6-405; R17-6-406; R17-6-408; R17-6-409			Over 14' - 16' = R	
US 60	MP 196.14 (Junction SR 88, Idaho Road) to MP 212.17 (Junction SR 79)	R17-6-405; R17-6-406; R17-6-408; R17-6-409			Over 14' - 16' = F/R	
US 60	MP 212.17 (Junction SR 79) to MP 226.87 (Junction SR 177)	R17-6-405; R17-6-406; R17-6-407; R17-6-408; R17-6-409			Over 14' - 16' = F/R	
US 60	MP 226.87 (Junction SR 177) to MP 227.71 (Queen Creek Bridge)	R17-6-406; R17-6-407; R17-6-408		80'+ unarticulated requires F/R; 110'+ articulated requires F/R	Over 10' - 14' = F/R Over 14' - 16' = F/R + 2 LE	
US 60	MP 227.71 (Queen Creek Bridge - Structure 406)	R17-6-406; R17-6-407; R17-6-408		80'+ unarticulated requires F/R; 110'+ articulated requires F/R	Over 10' - 14' = F/R Over 14' - 16' = F/R + 2 LE	Class A permitted vehicles with a gross weight of: 100,000 or less - no additional restrictions; 100,001 through 150,000 - drivers shall: Coordinate road closures by or under the direction of law enforcement; and Cross on center of bridge at a constant speed of no more than 10 mph while on bridge.  Class C permits and special analysis and approval from the ADOT Bridge Group are required for vehicles with a gross weight of 150,001 or more.

**ODPC Final Draft -  
(10/21/2011)**

Not yet approved or proposed

Route	Restriction Location (MP = Mile Post)	Movement Subject to:	Height	Length	Width	Weight (in lbs)
<b>Escort requirements: F = front escort, R = rear escort, F/R = front and rear escort, and LE = law enforcement escort</b>						
US 60	MP 227.71 (Queen Creek Bridge) to MP 228.47 (Queen Creek Tunnel)	R17-6-406; R17-6-407; R17-6-408		80'+ unarticulated requires F/R; 110'+ articulated requires F/R	Over 11' - 14' = F/R Over 14' - 16' = F/R + 2 LE	
US 60	MP 228.47 (Queen Creek Tunnel - Structure 407)	R17-6-406; R17-6-407; R17-6-408; *Loads 14' to 20' in height require F/R + 2 LE and shall drive in center of tunnel	14'*	80'+ unarticulated requires F/R; 110'+ articulated requires F/R	Over 11' - 14' = F/R Over 14' - 16' = F/R + 2 LE	
US 60	MP 228.47 (Queen Creek Tunnel) to MP 238.25 (Pinto Creek Bridge)	R17-6-406; R17-6-407; R17-6-408		80'+ unarticulated requires F/R; 110'+ articulated requires F/R	Over 11' - 14' = F/R Over 14' - 16' = F/R + 2 LE	
US 60	MP 238.25 (Pinto Creek Bridge - Structure 351)	R17-6-406; R17-6-407; R17-6-408		80'+ unarticulated requires F/R; 110'+ articulated requires F/R	Over 11' - 14' = F/R Over 14' - 16' = F/R + 2 LE	Class A permitted vehicles with a gross weight of: 100,000 or less - no additional restrictions; 100,001 through 150,000 - drivers shall: Coordinate road closures by or under the direction of law enforcement; and Cross on center of bridge at a constant speed of no more than 10 mph while on bridge.  Class C permits and special analysis and approval from the ADOT Bridge Group are required for vehicles with a gross weight of 150,001 or more.
US 60	MP 238.25 (Pinto Creek Bridge) to MP 247.04 (Junction SR 188)	R17-6-406; R17-6-407; R17-6-408		80'+ unarticulated requires F/R; 110'+ articulated requires F/R	Over 11' - 14' = F/R Over 14' - 16' = F/R + 2 LE	
US 60	MP 247.04 (Junction SR 188) to MP 252.06 (Junction US 70)	R17-6-406; R17-6-407; R17-6-408		80'+ unarticulated requires F/R; 110'+ articulated requires F/R	Over 11' - 14' = F/R Over 14' - 16' = F/R + 2 LE	
US 60	MP 252.06 (Junction US 70) to MP 292.91 (Apache Bridge)	R17-6-406; R17-6-408		80'+ unarticulated requires F/R; 110'+ articulated requires F/R	Over 12' - 14' = F/R Over 14' Prohibited	

**ODPC Final Draft -  
(10/21/2011)**

Not yet approved or proposed

Route	Restriction Location (MP = Mile Post)	Movement Subject to:	Height	Length	Width	Weight (in lbs)
<b>Escort requirements: F = front escort, R = rear escort, F/R = front and rear escort, and LE = law enforcement escort</b>						
US 60	MP 292.91 (Apache Bridge - Structure 1929)	R17-6-406; R17-6-408		80'+ unarticulated requires F/R; 110'+ articulated requires F/R	Over 12' - 14' = F/R + 2 LE Over 14' Prohibited	Class A permitted vehicles with a gross weight of: 150,000 or less - no additional restrictions; 150,001 through 250,000 - drivers shall: Coordinate road closures by or under the direction of law enforcement; and Cross on center of bridge at a constant speed of no more than 10 mph while on bridge.  Class C permitted vehicles with a gross weight of over 250,000 require special analysis and approval from the ADOT Bridge Group.
US 60	MP 292.91 (Apache Bridge) to MP 318.14 (Junction SR 73)	R17-6-406; R17-6-408		80'+ unarticulated requires F/R; 110'+ articulated requires F/R	Over 12' - 14' = F/R Over 14' Prohibited	
US 60	MP 318.14 (Junction SR 73) to MP 323.44 (Cedar Canyon Bridge)	R17-6-406; R17-6-408		80'+ unarticulated requires F/R; 110'+ articulated requires F/R	Over 12' - 14' = F/R Over 14' - 16' = F/R + 2 LE	
US 60	MP 323.44 (Cedar Canyon Bridge - Structure 215)	R17-6-406; R17-6-408		80'+ unarticulated requires F/R; 110'+ articulated requires F/R	Over 12' - 14' = F/R Over 14' - 16' = F/R + 2 LE	Class A permitted vehicles with a gross weight of: 100,000 or less - no additional restrictions; 100,001 through 150,000 - drivers shall: Coordinate road closures by or under the direction of law enforcement; and Cross on center of bridge at a constant speed of no more than 10 mph while on bridge.  Class C permits and special analysis and approval from the ADOT Bridge Group are required for vehicles with a gross weight of 150,001 or more.
US 60	MP 323.44 (Cedar Canyon Bridge) to MP 339.71 (Junction SR 260)	R17-6-406; R17-6-408		80'+ unarticulated requires F/R; 110'+ articulated requires F/R	Over 12' - 14' = F/R Over 14' - 16' = F/R + 2 LE	
US 60	MP 339.71 (Junction SR 260) to MP 341.69 (Junction SR 260)	R17-6-406; R17-6-408			Over 12' - 16' = F/R	
US 60	MP 341.69 (Junction SR 260) to MP 342.77 (Junction SR 77)	R17-6-406; R17-6-408			Over 12' - 16' = F/R	
US 60	MP 342.77 (Junction SR 77) to MP 353.16 (Junction SR 61)	R17-6-406; R17-6-408			Over 12' - 16' = F/R	

**ODPC Final Draft -  
(10/21/2011)**  
Not yet approved or proposed

Route	Restriction Location (MP = Mile Post)	Movement Subject to:	Height	Length	Width	Weight (in lbs)
<b>Escort requirements: F = front escort, R = rear escort, F/R = front and rear escort, and LE = law enforcement escort</b>						
US 60	MP 353.16 (Junction SR 61) to MP 384.45 (Junction US 180)	R17-6-406; R17-6-408			Over 12' - 16' = F/R	
US 60	MP 384.45 (Junction US 180) to MP 401.97 (New Mexico State Line)	R17-6-406; R17-6-408			Over 12' - 16' = F/R	
US 64	MP 465.40 (Junction US 160) to MP 469.54 (New Mexico State Line)	R17-6-406; R17-6-408			Over 14' - 16' = F/R	
US 70	MP 252.14 (Junction US 60) to MP 253.63 (Railroad Underpass)	R17-6-406; R17-6-408			Over 14' - 16' = F/R	
US 70	MP 253.63 (Railroad Underpass - Structure 562)	R17-6-406; R17-6-408	15' 6"		Over 14' - 16' = F/R	
US 70	MP 253.63 (Railroad Underpass) to MP 254.11 (Junction SR 77)	R17-6-406; R17-6-408			Over 14' - 16' = F/R	
US 70	MP 254.11 (Junction SR 77) to MP 292.55 (Gila River Bridge at Bylas)	R17-6-406; R17-6-408			Over 14' - 16' = F/R	
US 70	MP 292.55 (Gila River Bridge at Bylas - Structure 498)	R17-6-406; R17-6-408			Over 14' - 16' = F/R	Legal weight as provided under R17-6-102, Table 1.
US 70	MP 292.55 (Gila River Bridge at Bylas) to MP 339.45 (Junction US 191)	R17-6-406; R17-6-408			Over 14' - 16' = F/R	
US 70	MP 339.45 (Junction US 191) to MP 349.48 (Junction US 191)	R17-6-406; R17-6-408			Over 14' - 16' = F/R	
US 70	MP 349.48 (Junction US 191) to MP 378.90 (Junction SR 75)	R17-6-406; R17-6-408			Over 14' - 16' = F/R	
US 70	MP 378.90 (Junction SR 75) to MP 385.25 (New Mexico State Line)	R17-6-406; R17-6-408			Over 14' - 16' = F/R	
US 89	MP 401.00 (Junction I-40) to MP 403.18 (Junction SB 40)	R17-6-406; R17-6-408			Over 14' - 16' = F/R	
US 89	MP 418.59 (Junction SB 40) to MP 465.21 (Junction SR 64)	R17-6-406; R17-6-408			Over 14' - 16' = F/R	
US 89	MP 465.21 (Junction SR 64) to MP 466.88 (Cameron Bridge)	R17-6-406; R17-6-408			Over 14' - 16' = F/R	

**ODPC Final Draft -  
(10/21/2011)**  
Not yet approved or proposed

Route	Restriction Location (MP = Mile Post)	Movement Subject to:	Height	Length	Width	Weight (in lbs)
<b>Escort requirements: F = front escort, R = rear escort, F/R = front and rear escort, and LE = law enforcement escort</b>						
US 89	MP 466.88 (Cameron Bridge - Structure 532)	R17-6-406; R17-6-408			Over 14' - 16' = F/R + 2 LE	Class A permitted vehicles with a gross weight of: 100,000 or less - no additional restrictions; 100,001 through 150,000 - drivers shall: Coordinate road closures by or under the direction of law enforcement; and Cross on center of bridge at a constant speed of no more than 10 mph while on bridge.  Class C permits and special analysis and approval from the ADOT Bridge Group are required for vehicles with a gross weight of 150,001 or more.
US 89	MP 466.88 (Cameron Bridge) to MP 480.80 (Junction US 160)	R17-6-406; R17-6-408			Over 14' - 16' = F/R	
US 89	MP 480.80 (Junction US 160) to MP 524.01 (Junction US 89A)	R17-6-406; R17-6-408			Over 14' - 16' = F/R	
US 89	MP 524.01 (Junction US 89A) to MP 546.20 (Junction SR 98)	R17-6-406; R17-6-408			Over 14' - 16' = F/R	
US 89	MP 546.20 (Junction SR 98) to MP 549.54 (Glen Canyon Bridge)	R17-6-406; R17-6-408			Over 14' - 16' = F/R	
US 89	MP 549.54 (Glen Canyon Bridge - Structure 537)	R17-6-406; R17-6-408			Over 14' - 16' = F/R + 2 LE	Class A permitted vehicles with a gross weight of: 150,000 or less - no additional restrictions; 150,001 through 250,000 - drivers shall: Coordinate road closures by or under the direction of law enforcement; and Cross on center of bridge at a constant speed of no more than 10 mph while on bridge.  Class C permitted vehicles with a gross weight of over 250,000 require special analysis and approval from the ADOT Bridge Group.
US 89	MP 549.54 (Glen Canyon Bridge) to MP 556.99 (Utah State Line)	R17-6-406; R17-6-408			Over 14' - 16' = F/R	
US 89A	MP 524.07 (Junction US 89) to MP 537.86 (Navajo Bridge at Colorado River)	R17-6-406; R17-6-408			Over 10' - 14' = F/R Over 14' - 16' = F/R + 2 LE	

**ODPC Final Draft -  
(10/21/2011)**  
Not yet approved or proposed

Route	Restriction Location (MP = Mile Post)	Movement Subject to:	Height	Length	Width	Weight (in lbs)
<b>Escort requirements: F = front escort, R = rear escort, F/R = front and rear escort, and LE = law enforcement escort</b>						
US 89A	MP 537.86 (Navajo Bridge at Colorado River - Structure 2340)	R17-6-406; R17-6-408			Over 10' - 14' = F/R Over 14' - 16' = F/R + 2 LE	Class A permitted vehicles with a gross weight of: 150,000 or less - no additional restrictions; 150,001 through 250,000 - drivers shall: Coordinate road closures by or under the direction of law enforcement; and Cross on center of bridge at a constant speed of no more than 10 mph while on bridge.  Class C permitted vehicles with a gross weight of over 250,000 require special analysis and approval from the ADOT Bridge Group.
US 89A	MP 537.86 (Navajo Bridge at Colorado River) to MP 547.00 (Cliffdweller's Lodge)	R17-6-406; R17-6-408			Over 10' - 14' = F/R Over 14' - 16' = F/R + 2 LE	
US 89A	MP 547.00 (Cliffdweller's Lodge) to MP 579.30 (Junction SR 67)	R17-6-406; R17-6-408			Over 8' 6" requires class C permit	
US 89A	MP 579.30 (Junction SR 67) to MP 609.23 (Junction SR 389)	R17-6-406; R17-6-408			Over 12' - 16' = F/R	
US 89A	MP 609.23 (Junction SR 389) to MP 613.03 (Utah State Line)	R17-6-406; R17-6-408			Over 12' - 16' = F/R	
US 93	MP 0.00 (Hoover Dam) to MP 67.20 (Junction SR 68)	R17-6-405; R17-6-406; R17-6-408; R17-6-409			Over 14' - 16' = F/R	Nevada issues permit for Mike O'Callaghan – Pat Tillman Memorial Bridge (Colorado River Bridge)
US 93	MP 67.20 (Junction SR 68) to MP 71.10 (Junction I-40, Exit # 48)	R17-6-405; R17-6-406; R17-6-408; R17-6-409			Over 14' - 16' = F/R	
US 93	MP 91.38 (Junction I-40, Exit # 71) to MP 139.07 Southbound (Burro Creek Bridge)	R17-6-406; R17-6-407; R17-6-408			Over 14' - 16' = F/R + 2 LE	
US 93	MP 139.07 Southbound (Burro Creek Bridge - Structure 846)	R17-6-406; R17-6-407; R17-6-408			Over 14' - 16' = F/R + 2 LE	Class A permitted vehicles with a gross weight of: 150,000 or less - no additional restrictions; 150,001 through 250,000 - drivers shall: Coordinate road closures by or under the direction of law enforcement; and Cross on center of bridge at a constant speed of no more than 10 mph while on bridge.  Class C permitted vehicles with a gross weight of over 250,000 require special analysis and approval from the ADOT Bridge Group.
US 93	MP 139.07 Southbound (Burro Creek Bridge) to MP 154.85 (Junction SR 97)	R17-6-406; R17-6-407; R17-6-408			Over 14' - 16' = F/R + 2 LE	

**ODPC Final Draft -  
(10/21/2011)**  
Not yet approved or proposed

Route	Restriction Location (MP = Mile Post)	Movement Subject to:	Height	Length	Width	Weight (in lbs)
<b>Escort requirements: F = front escort, R = rear escort, F/R = front and rear escort, and LE = law enforcement escort</b>						
US 93	MP 154.85 (Junction SR 97) to MP 182.90 (Junction SR 71)	R17-6-406; R17-6-407; R17-6-408			Over 14' - 16' = F/R + 2 LE	
US 93	MP 182.90 (Junction SR 71) to MP 193.61 (Junction SR 89)	R17-6-406; R17-6-407; R17-6-408			Over 14' - 16' = F/R + 2 LE	
US 93	MP 193.61 (Junction SR 89) to MP 199.67 (Junction US 60 in Wickenburg)	R17-6-406; R17-6-407; R17-6-408			Over 14' - 16' = F/R + 2 LE	
US 95	MP 0.00 (US/Mexico Border) to MP 19.84 (32nd Street East)	R17-6-406; R17-6-408			Over 14' - 16' = F/R	
US 95	MP 19.84 (32nd Street East) to MP 24.35 (Junction I-8)	R17-6-404; R17-6-405; R17-6-406; R17-6-408; R17-6-409			Over 14' - 16' = F/R	
US 95	MP 24.35 (Junction I-8) to MP 31.87 (Avenue 9E)	R17-6-404; R17-6-405; R17-6-406; R17-6-408; R17-6-409			Over 14' - 16' = F/R	
US 95	MP 31.87 (Avenue 9E) to MP 104.25 (Junction I-10)	R17-6-406; R17-6-408			Over 14' - 16' = F/R	
US 95	MP 104.25 (Junction I-10) to MP 104.51 (SB 10 in Quartzsite)	R17-6-406; R17-6-408			Over 14' - 16' = F/R	
US 160	MP 311.46 (Junction US 89) to MP 321.86 (Junction SR 264)	R17-6-406; R17-6-408			Over 14' - 16' = F/R	
US 160	MP 321.86 (Junction SR 264) to MP 361.61 (Junction SR 98)	R17-6-406; R17-6-408			Over 14' - 16' = F/R	
US 160	MP 361.61 (Junction SR 98) to MP 374.28 (Junction SR 564)	R17-6-406; R17-6-408			Over 14' - 16' = F/R	
US 160	MP 374.28 (Junction SR 564) to MP 393.57 (Junction US 163)	R17-6-406; R17-6-408			Over 14' - 16' = F/R	
US 160	MP 393.57 (Junction US 163) to MP 434.87 (Junction US 191)	R17-6-406; R17-6-408			Over 14' - 16' = F/R	
US 160	MP 434.87 (Junction US 191) to MP 437.22 (Junction US 191; BIA 12)	R17-6-406; R17-6-408			Over 14' - 16' = F/R	
US 160	MP 437.22 (Junction US 191; BIA 12) to MP 465.40 (Junction US 64)	R17-6-406; R17-6-408			Over 14' - 16' = F/R	
US 160	MP 465.40 (Junction US 64) to MP 470.73 (New Mexico State Line)	R17-6-406; R17-6-408			Over 14' - 16' = F/R	
US 163	MP 393.52 (Junction US 160) to MP 396.16 (Laguna Wash Bridge)	R17-6-406; R17-6-408			Over 12' - 16' = F/R	

**ODPC Final Draft -  
(10/21/2011)**  
Not yet approved or proposed

Route	Restriction Location (MP = Mile Post)	Movement Subject to:	Height	Length	Width	Weight (in lbs)
<b>Escort requirements: F = front escort, R = rear escort, F/R = front and rear escort, and LE = law enforcement escort</b>						
US 163	MP 396.16 (Laguna Wash Bridge - Structure 25)	R17-6-406; R17-6-408			Over 12' - 16' = F/R + 2 LE	Class A permitted vehicles with a gross weight of: 100,000 or less - no additional restrictions; 100,001 through 150,000 - drivers shall: Coordinate road closures by or under the direction of law enforcement; and Cross on center of bridge at a constant speed of no more than 10 mph while on bridge.  Class C permits and special analysis and approval from the ADOT Bridge Group are required for vehicles with a gross weight of 150,001 or more.
US 163	MP 396.16 (Laguna Wash Bridge) to MP 416.71 (Utah State Line)	R17-6-406; R17-6-408			Over 12' - 16' = F/R	
US 180	MP 215.44 (Junction SB 40) to MP 265.82 (Junction SR 64)	R17-6-406; R17-6-408			Over 12' - 16' = F/R	
US 180	MP 307.30 (Junction SR 77) to MP 343.13 (Junction SR 180A)	R17-6-406; R17-6-408			Over 12' - 16' = F/R	
US 180	MP 343.13 (Junction SR 180A) to MP 358.44 (Junction SR 61)	R17-6-406; R17-6-408			Over 12' - 16' = F/R	
US 180	MP 358.44 (Junction SR 61) to MP 368.92 (Junction US 191)	R17-6-406; R17-6-408			Over 12' - 16' = F/R	
US 180	MP 368.92 (Junction US 191) to MP 394.36 (Junction US 60)	R17-6-406; R17-6-408			Over 12' - 16' = F/R	
US 180	MP 400.61 (Junction US 60) to MP 426.33 (Junction US 191)	R17-6-406; R17-6-408			Over 12' - 16' = F/R	
US 180	MP 426.33 (Junction US 191) to MP 433.26 (New Mexico State Line)	R17-6-406; R17-6-408			Over 12' - 16' = F/R	
US 191	MP 0.00 (Junction SR 80) to MP 38.12 (Junction SR 181)	R17-6-406; R17-6-408			Over 14' - 16' = F/R	
US 191	MP 38.12 (Junction SR 181) to MP 66.55 (Junction I-10)	R17-6-406; R17-6-408			Over 14' - 16' = F/R	
US 191	MP 87.43 (Junction I-10) to MP 104.38 (Junction SR 266)	R17-6-406; R17-6-408			Over 14' - 16' = F/R	
US 191	MP 104.38 (Junction SR 266) to MP 113.69 (Junction SR 366)	R17-6-406; R17-6-408			Over 14' - 16' = F/R	
US 191	MP 113.69 (Junction SR 366) to MP 121.02 (Junction US 70)	R17-6-406; R17-6-408			Over 14' - 16' = F/R	
US 191	MP 130.60 (Junction US 70) to MP 154.90 Southbound (Cold Creek Bridge)	R17-6-406; R17-6-408			Over 14' - 16' = F/R	

**ODPC Final Draft -  
(10/21/2011)**

Not yet approved or proposed

Route	Restriction Location (MP = Mile Post)	Movement Subject to:	Height	Length	Width	Weight (in lbs)
<b>Escort requirements: F = front escort, R = rear escort, F/R = front and rear escort, and LE = law enforcement escort</b>						
US 191	MP 154.90 Southbound (Cold Creek Bridge - Structure 258)	R17-6-406; R17-6-408			Over 14' - 16' = F/R + 2 LE	Class A permitted vehicles with a gross weight of: 150,000 or less - no additional restrictions; 150,001 through 250,000 - drivers shall: Coordinate road closures by or under the direction of law enforcement; and Cross on center of bridge at a constant speed of no more than 10 mph while on bridge.  Class C permitted vehicles with a gross weight of over 250,000 require special analysis and approval from the ADOT Bridge Group.
US 191	MP 154.90 Southbound (Cold Creek Bridge) to MP 163.95 (Temporary US 191, Clifton)	R17-6-406; R17-6-408			Over 14' - 16' = F/R	
US 191	MP 179.36 (Junction at end of Temporary US 191) to MP 253.74 (Junction US 180, Alpine)	R17-6-406; R17-6-408		Over 40' requires class C permit	Over 8' requires class C permit	
US 191	MP 315.55 (Junction US 180 in St Johns) to MP 344.49 (Junction SR 61)	R17-6-406; R17-6-408			Over 14' - 16' = F/R	
US 191	MP 344.49 (Junction SR 61) to MP 368.47 (Railroad overpass, Sanders)	R17-6-406; R17-6-408			Over 14' - 16' = F/R	
US 191	MP 368.47 (Railroad overpass, Sanders - Structure 346)	R17-6-406; R17-6-408			Over 8' requires class C permit	Legal weight as provided under R17-6-102, Table 1.
US 191	MP 368.47 (Railroad overpass, Sanders) to MP 368.50 (Junction I-40 in Sanders)	R17-6-406; R17-6-408			Over 14' - 16' = F/R	
US 191	MP 374.00 (Junction I-40) to MP 411.63 (Junction SR 264, Ganado)	R17-6-406; R17-6-408			Over 12' - 16' = F/R	
US 191	MP 417.55 (Junction SR 264) to MP 510.34 (Junction US 160)	R17-6-406; R17-6-408			Over 12' - 16' = F/R	
UX 191	MP 163.95 (Temporary US 191, Clifton) to MP 169.00 (Phelps Dodge Mine entrance)	R17-6-406; R17-6-408			Over 8' requires class C permit	
UX 191	MP 169.00 (Phelps Dodge Mine entrance) to MP 169.20 (Phelps Dodge Viaduct)	R17-6-406; R17-6-408			Over 8' requires class C permit	

**ODPC Final Draft -  
(10/21/2011)**  
Not yet approved or proposed

Route	Restriction Location (MP = Mile Post)	Movement Subject to:	Height	Length	Width	Weight (in lbs)
<b>Escort requirements: F = front escort, R = rear escort, F/R = front and rear escort, and LE = law enforcement escort</b>						
UX 191	MP 169.20 (Phelps Dodge Viaduct - Structure 1631)	R17-6-406; R17-6-408			Over 8' requires class C permit	Class A permitted vehicles with a gross weight of: 100,000 or less - no additional restrictions; 100,001 through 150,000 - drivers shall: Coordinate road closures by or under the direction of law enforcement; and Cross on center of bridge at a constant speed of no more than 10 mph while on bridge.  Class C permits and special analysis and approval from the ADOT Bridge Group are required for vehicles with a gross weight of 150,001 or more.
UX 191	MP 169.20 (Phelps Dodge Viaduct) to MP 169.30 (Railroad Underpass)	R17-6-406; R17-6-408			Over 8' requires class C permit	
UX 191	MP 169.30 (Railroad Underpass - Structure 1632)	R17-6-406; R17-6-408	15'		Over 8' requires class C permit	
UX 191	MP 169.30 (Railroad Underpass) to MP 169.39 (Rock Tunnel)	R17-6-406; R17-6-408			Over 8' requires class C permit	
UX 191	MP 169.39 (Rock Tunnel - Structure 1633)	R17-6-406; R17-6-408	12' 6"		Over 8' requires class C permit	
UX 191	MP 169.39 (Rock Tunnel) to MP 179.36 (Junction at end of Temporary US 191)	R17-6-406; R17-6-408			Over 8' requires class C permit	

**R17-6-413. Page-Lake Powell Area Houseboat Transport Provisions**

- A. A permit applicant shall use the procedures ~~in~~ under this Section to apply for ~~a~~ an extended approval class C special permit to transport a houseboat of the dimensions specified ~~in~~ under subsection (C) ~~for~~ on a highway listed ~~in~~ under Table 5.
- B. A permit applicant shall apply for a permit under this Section at the following Department field office:  
 Page Port of Entry  
 US 89 MP 551  
 P.O. Box 1807  
 Page, AZ 86040  
 Telephone: (928) 645-3269  
 Fax: (928) 645-9360
- C. ~~A~~ An extended approval class C special permitted ~~load~~ vehicle with at least one front and one rear escort vehicle may operate on a highway listed under Table 5 during daylight hours as prescribed under ~~R17-6-401(1)~~ R17-6-401 including any weekday, weekend, or holiday, if it does not exceed dimensions as follows:
1. 16 feet 6 inches ~~wide,~~ in width;
  2. 25 feet ~~high,~~ in height;
  3. 120 feet ~~long,~~ in length; ~~or~~
  4. 150,000 pounds, ~~and,~~
  5. ~~Axle weight limits listed in Tables 3-01 through 3-09.~~
- D. ~~A~~ An extended approval class C special permitted vehicle and load that exceeds 17 feet ~~high~~ in height shall have a front escort with a height pole.
- E. For a an extended approval class C special permitted vehicle and load that exceeds 14 feet ~~wide~~ in width, a permittee shall ensure ~~for~~ an appropriate level of traffic control at the Glen Canyon Bridge on US 89 by closing access to the bridge at each end and at the visitor center driveway.
- F. If a permit applicant seeks to transport outside the requirements of this Section, the permit applicant shall apply for a class C special permit according to the procedures provided under ~~R17-6-104~~ R17-6-204.

**Table 5. Page-Lake Powell Area Highways**

<b>Highway</b>	<b>From</b>	<b>To</b>
State Route 98	Copper Mine Road	Haul Road
US 89	Haul Road	Lake Shore Drive
US 89	Lake Shore Drive	Haul Road
State Route 98	Haul Road	Copper Mine Road
US 89	Lake Powell Blvd.	Lake Shore Drive

US 89	Lake Shore Drive	Lake Powell Blvd.
US 89	Haul Road	Lake Shore Drive
US 89	Lake Shore Drive	Haul Road
US 89	State line	Lake Shore Drive
US 89	Lake Shore Drive	State line
State Route 98	Navajo Plant (approximately post marker 299)	US 89 to Lake Shore Drive
US 89	Lake Shore Drive to SR 98	Navajo Plant (approximately post marker 299)
State Route 98	Copper Mine Road	Navajo Plant (approximately post marker 299)
State Route 98	Navajo Plant (approximately post marker 299)	Copper Mine Road
State Route 98	Copper Mine Road	US 89 to Lake Shore Drive
US 89	Lake Shore Drive	State Route 98 to Copper Mine Road

<u>Route</u>	<u>Location</u>
<u>(MP = Mile Post)</u>	
SR 98	MP 299.50 (Junction BIA 22, Antelope Canyon); to MP 294.67 (End of route at Junction US 89)
US 89	MP 546.19 (Junction SR 98); to MP 556.99 (Utah State Line)

**R17-6-407-R17-6-414. Lake-specific Weekend and Holiday Transport Exception**

A permittee ~~or driver under class A or H~~ that transports a personal watercraft load ~~not wider of no more than 12 feet~~ in width under a class A special permit, may operate from one-half hour before sunrise to one-half hour after sunset on a weekend or holiday on a state highway within ~~ten~~ 10 miles of an area constructed and maintained for the purpose of launching and retrieving watercraft for the following Arizona lakes:

1. Alamo,
2. Havasu,
3. Mead,
4. Mohave,
5. Powell, ~~or~~ and
6. Saguaro.

## ARTICLE 5. ENVELOPE PERMIT SPECIAL PROVISIONS

### **R17-6-501. Envelope Permit Required Recordkeeping**

~~A.~~ As prescribed under A.R.S. § 28-1149, an envelope permittee shall retain records:

- ~~1. For three years,~~
- ~~2. At an established place of business,~~
- ~~3. For each transported load, and~~
- ~~4. Consisting of the following:~~
  - ~~a. Bill of lading,~~
  - ~~b. Shipping manifest, and~~
  - ~~c. Each time card or invoice.~~

A. An envelope permit holder shall maintain in this state, for at least three years, records and other data for all vehicles operated, and cargo transported, under an envelope permit as required under A.R.S. § 28-1149. The records and other data shall include:

1. Bills of lading,
2. Shipping manifests, and
3. Time cards or invoices.

B. A ~~retained~~ record retained by an envelope permit holder under subsection ~~(A)(4)~~ (A) shall contain, at least, the following information:

- ~~1. Document preparation date,~~
  - ~~2. Name of shipper and receiver,~~
  - ~~3. Load origin and destination,~~
  - ~~4. Dates of transit, and~~
  - ~~5. Transit route.~~
1. Date of document preparation,
  2. Name of shipper and name of receiver,
  3. Address of load origination and address of destination, and
  4. Dates of transport.

### **R17-6-502. Envelope Permit Suspension Point System**

The Director shall ~~implement provisions~~ suspend an envelope permit, as prescribed under A.R.S. § 28-1147, by assigning points to the permittee for envelope permit violations as follows:

1. Minor violations - one point:
  - a. Improper or inadequate flagging as ~~prescribed~~ under R17-6-302; and R17-6-307,
  - b. Improper or inadequate lighting as ~~prescribed~~ under R17-6-304; and R17-6-307,
  - c. Improper or inadequate "OVERSIZE LOAD" signage display as ~~prescribed~~ under R17-6-303,
  - d. Use of an ~~improperly equipped~~ escort vehicle not properly or adequately equipped as prescribed under R17-6-305,

- e. ~~Failure~~ Failing to maintain proper follow-distance from another ~~overdimensional~~ oversize or overweight vehicle or load as prescribed under ~~R17-6-401(3), R17-6-401, or~~
  - f. ~~Failure of an escort vehicle to maintain proper distance as prescribed under R17-6-305, and~~  
~~g-f.~~ Exceeding permitted speed but not exceeding posted speed as prescribed under R17-6-402.
2. Major violations - three points:
- a. Moving a permitted ~~load~~ vehicle or load on a curfew-restricted highway during the curfew hours as prescribed under R17-6-404 through ~~R17-6-406, R17-6-407 or R17-6-412, Table 4;~~
  - b. ~~Failure~~ Failing to display flags or lights when required under R17-6-302, ~~or~~ R17-6-304, or R17-6-307;
  - c. ~~Failure~~ Failing to display "OVERSIZE LOAD" signage when required under R17-6-303;
  - d. Exceeding the posted speed limit, ~~and;~~ or
  - e. Moving a reducible load ~~with a~~ under an envelope permit.
3. Weight Violations, 1-36 points:
- a. Gross vehicle weight exceeds ~~weight as allowed by~~ the allowable weight prescribed under R17-6-411; A.R.S. § 28-1099, or 28-1100:
    - i. Less than 2% over allowable weight - one point,
    - ii. 2% but less than 4% over allowable weight - two points,
    - iii. 4% but less than 6% over allowable weight - three points,
    - iv. 6% but less than 9% over allowable weight - six points,
    - v. 9% but less than 12% over allowable weight - 10 points,
    - vi. 12% but less than 15% over allowable weight - 18 points, ~~and~~ or
    - vii. 15% or more over allowable weight - 36 points.
  - b. For each axle group exceeding the allowable weight ~~as allowed by~~ prescribed under R17-6-411; A.R.S. § 28-1099, or 28-1100:
    - i. Less than 4% over allowable weight - one point,
    - ii. 4% but less than 6% over allowable weight - two points,
    - iii. 6% but less than 9% over allowable weight - four points,
    - iv. 9% but less than 12% over allowable weight - six points,
    - v. 12% but less than 15% over allowable weight - 10 points,
    - vi. 15% but less than 20% over allowable weight - 18 points, ~~and~~ or
    - vii. 20% or more over allowable weight - 36 points.
4. Flagrant Violations - 36 points:
- a. Moving a permitted load on a highway under weather restrictions ~~as~~ prescribed under R17-6-403 or in violation of a law enforcement agency order,
  - b. Exceeding an envelope dimension ~~as~~ prescribed under ~~R17-6-101(B)(9)~~ R17-6-101,
  - c. Falsifying a permit application,
  - d. Altering a permit,

- e. ~~Failure~~ Failing to pay repair cost for permittee caused highway damage ~~costs for highway damages~~ as prescribed under A.R.S. § 28-1107,
- f. Moving a permitted load on a restricted highway or restricted bridge, ~~and~~
- g. ~~Failure~~ Failing to use a ~~required~~ an escort vehicle as prescribed under R17-6-305- ~~or~~
- h. Failing to use an escort vehicle with a driver properly certified under R17-6-305.

**R17-6-503. Envelope Permit Suspension; Revocation; Enforcement**

- A. The ~~Department~~ Director shall suspend an envelope permit for point accumulation within any 12-month period according to the following schedule:
  - 1. 14-19 points, one-week suspension;~~;~~
  - 2. 20-29 points, two-week suspension;~~;~~
  - 3. 30-35 points, four-week suspension;~~;~~ and
  - 4. More than 35 points, ~~a suspension period as determined by the Department for up to one year~~ one-year suspension.
- B. The ~~Department~~ Director shall revoke an envelope permit under A.R.S. § 28-1147 for the following reasons:
  - 1. Frequency of violation indicates a flagrant disregard for the law or the safety of the public,
  - 2. A permittee does not have an established place of business, or
  - 3. A permittee fails to maintain records ~~required as prescribed~~ under R17-6-501 and A.R.S. § 28-1149.
- C. A permittee shall surrender the permit to the Department within 72 hours after an order of suspension or revocation is effective.
  - 1. If the permittee fails to surrender the permit within five working days of oral or written demand, the ~~Department~~ Director shall suspend the permittee's envelope permit privileges for one year in addition to any other penalty assessed.
  - 2. The Department shall retrieve the permit if the permittee fails to return the permit within the prescribed time.
- D. The Department shall not issue an envelope permit to a permittee during the permittee's period of suspension or revocation.

**R17-6-504. Notice of Point Assessment, Denial, Suspension, or Revocation**

- A. The ~~Division~~ Department shall send to a permittee's last known address of record notice of the following:
  - 1. Point assessment; or
  - 2. Permit denial, suspension, or revocation.
- B. The notice shall inform the permittee of:
  - 1. The right to appeal the action, and
  - 2. The procedure for requesting a hearing.

- C. Any action prescribed under this Section becomes effective 25 days after the Division's action notice date unless a permittee submits a timely hearing request ~~that complies with procedure prescribed under R17-1-502 as provided under 17 A.A.C. 1, Article 5.~~

**R17-6-505. Envelope Permit Reapplication**

- A. ~~If an envelope permit is denied, the applicant may reapply immediately.~~ An envelope permit applicant denied issuance by the Department, as prescribed under A.R.S. § 28-1142, shall not reapply for an envelope permit for two years from the date of denial.
- B. ~~If an envelope permit is revoked, the revoked permittee shall not reapply until after the revocation period is terminated.~~ An envelope permit applicant, who has previously had an envelope permit revoked by the Department under A.R.S. § 28-1147, shall not reapply for an envelope permit for two years from the date of revocation.
- C. Upon reapplication, an applicant shall show by a preponderance of evidence that the underlying cause for denial or revocation has been removed.