

Sign Lighting Mount with 85 Watt Inductive Fluorescent Fixture

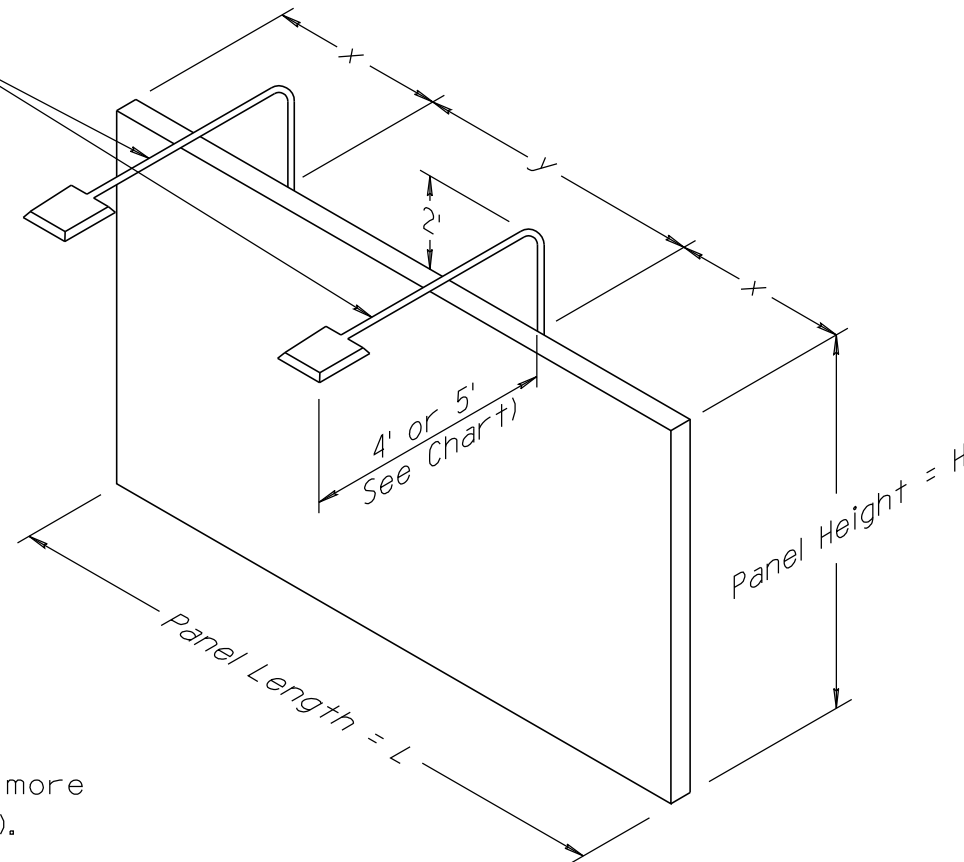

x = Distance from edge of panel.

y = Distance between sign light mount when more than one fixture is required (see chart).

NOTES:

1. All materials and construction shall conform to the requirements of the Specifications.
2. When sign panels are placed side by side, locate the lighting fixtures using the sum of the sign panel lengths.
3. When sign panel heights do not equal heights shown, round up to the next whole number shown.
4. Panel height "H", includes exit panel sign.
5. Use top-mount sign lighting.
6. The spacing and number of fixtures shown on this drawing is based on HPS sign light, not 85 Watt Philips QL lamp, actual layout and number of fixtures may vary based on photometric calculations.
7. Lighting loss factor (LLF) is to be 0.75.
8. Lumen rating is to be 6,300 lumens.
9. The Lighting performance criteria is: 6 to 10 footcandels average with a 3 to 1 or better average to minimum and a 5.5 to 1 maximum to minimum uniformity ratios.

Location Of Sign Lighting Mount (Dimensions in Feet)

Sign Size (HxL)	6x6	6x8	6x10	6x12	6x14	6x16	6x18	6x20	6x22	6x24	6x26	6x28	6x30	8x8	8x10	8x12	8x14	8x16	8x18	8x20	8x22	8x24	8x26	8x28	8x30	10x10	10x12	10x14	10x16	10x18	10x20	10x22	10x24	10x26	10x28	10x30	
Number of Fixtures	1	1	1	1	1	1	2	2	2	2	2	2	2	1	1	1	1	1	2	2	2	2	2	2	2	1	1	1	1	2	2	2	2	2	2	2	2
Mount Size	4x2	4x2	4x2	4x2	4x2	4x2	4x2	4x2	4x2	4x2	4x2	4x2	4x2	4x2	4x2	4x2	4x2	4x2	4x2	4x2	4x2	4x2	4x2	4x2	4x2	4x2	4x2	4x2	4x2	4x2	4x2	4x2	4x2	4x2	4x2	4x2	4x2
"X" feet	3	4	5	6	7	8	3	4	4	5	6	6	7	4	5	6	7	8	3	4	4	5	6	6	7	5	6	7	8	3	4	4	5	6	6	7	
"Y" feet	0	0	0	0	0	0	12	12	14	14	14	16	16	0	0	0	0	0	12	12	14	14	14	16	16	0	0	0	0	12	12	14	14	14	16	16	

Sign Size (HxL)	12x10	12x12	12x14	12x16	12x18	12x20	12x22	12x24	12x26	12x28	12x30	14x8	14x10	14x12	14x14	14x16	14x18	14x20	14x22	14x24	14x26	14x28	14x30
Number of Fixtures	2	2	2	2	2	2	3	3	3	3	3	2	2	2	2	2	2	3	3	3	3	3	3
Mount Size	5x2	5x2	5x2	5x2	5x2	5x2	5x2	5x2	5x2	5x2	5x2	5x2	5x2	5x2	5x2	5x2	5x2	5x2	5x2	5x2	5x2	5x2	5x2
"X" feet	2	3	3	3	3	4	2	3	3	3	3	2	2	3	3	3	3	4	2	3	3	3	3
"Y" feet	6	6	8	10	12	12	9	9	10	11	12	4	6	6	8	10	12	12	9	9	11	11	12

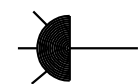

PLAN SYMBOL

DESIGN APPROVED SIGNATURE	ARIZONA DEPARTMENT OF TRANSPORTATION INTERMODAL TRANSPORTATION DIVISION TRAFFIC SIGNALS AND LIGHTING STANDARD DRAWINGS	REVISION 03/10
APPROVED FOR DISTRIBUTION ON FILE	PLACEMENT OF LIGHTING FIXTURES FOR OVERHEAD SIGNS	DRAWING NO. T.S. 13-3
		SHEET NO. 1 OF 1

NOT TO SCALE