

F.H.W.A. REGION	STATE	PROJECT NO.	SHEET NO.	TOTAL SHEETS	AS BUILT
9	ARIZ.				

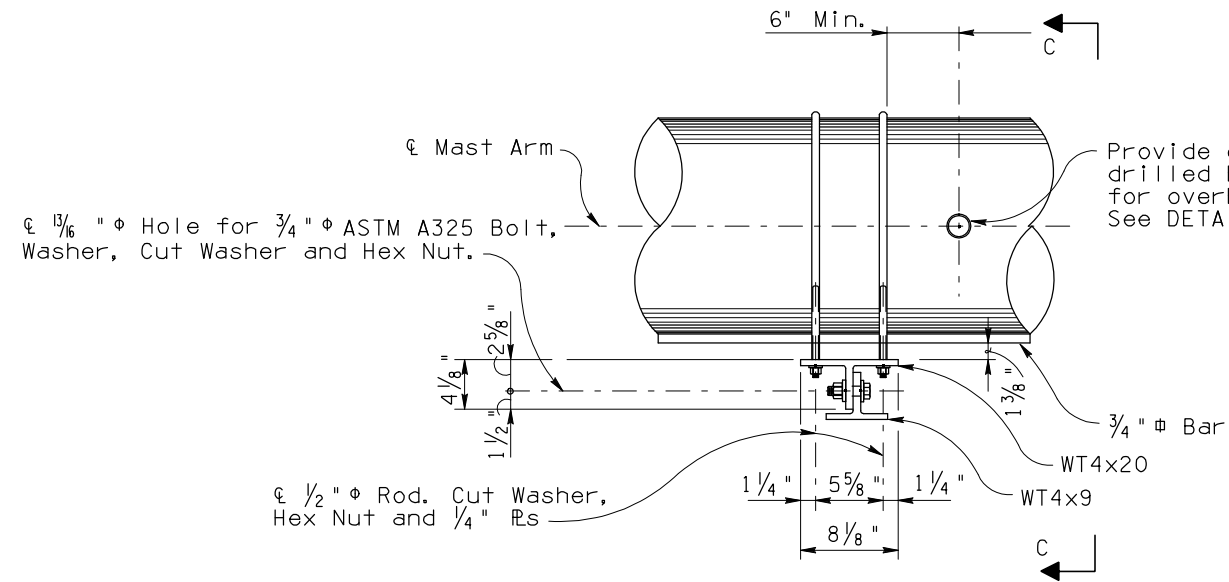

PLAN
SIGN MOUNTING BRACKET

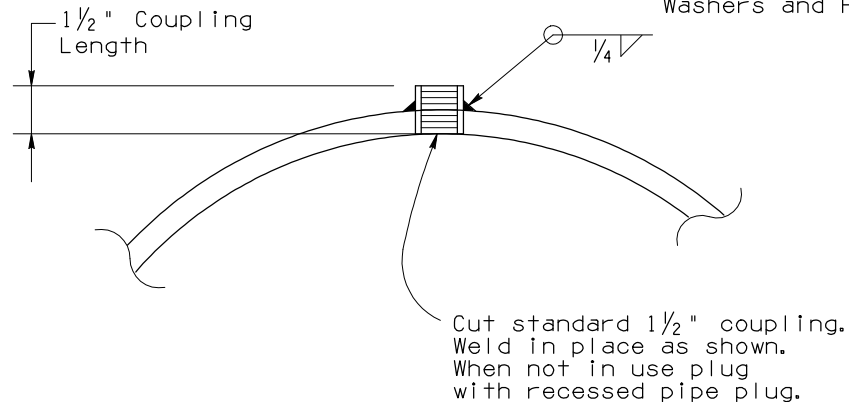

DETAIL D

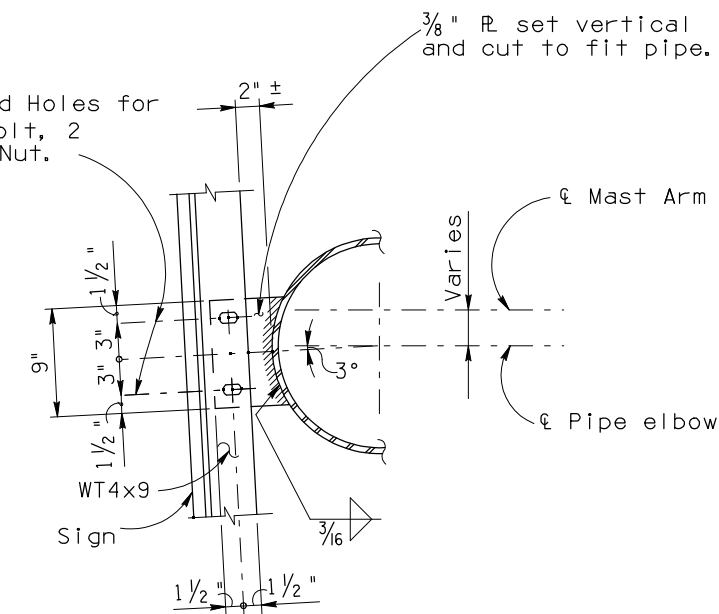

ELEVATION
SIGN MOUNTING BRACKET AT ELBOW

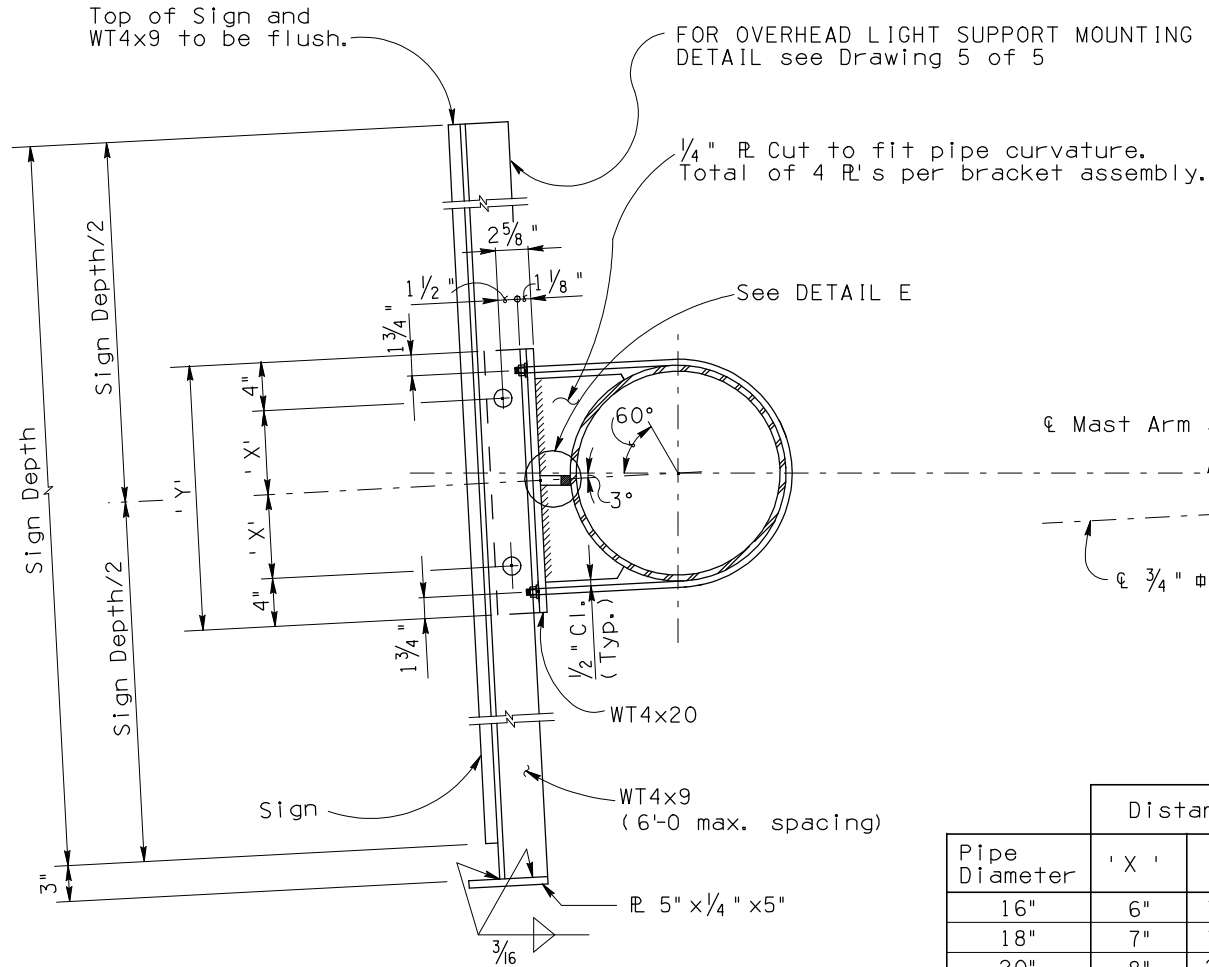

ELEVATION C-C

Pipe Diameter	Distance	
	'X'	'Y'
16"	6"	1'-8"
18"	7"	1'-10"
20"	8"	2'-0"
22"	9"	2'-2"

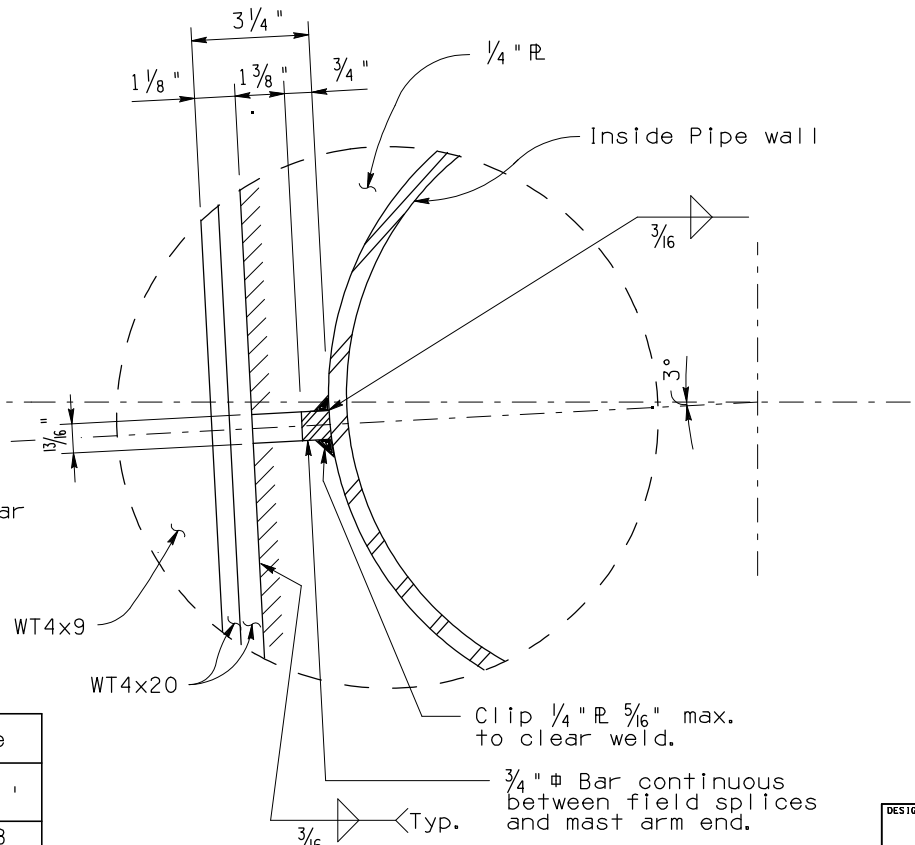

DETAIL E

Note to Designer:
 The information presented in this Standard Detail has been prepared in accordance with recognized engineering principles and is for general use. It should not be used for specific application without competent professional examination and verification of its suitability and applicability by a licensed professional engineer. Contents within the inner border line shall not be altered.

NO.	DESCRIPTION OF REVISIONS	MADE BY	DATE
1	Original Issue	J.R.P.	6-01
2			
3			
4			

DESIGN APPROVED <i>James R. Pyne</i>	ARIZONA DEPARTMENT OF TRANSPORTATION INTERMODAL TRANSPORTATION DIVISION BRIDGE GROUP STRUCTURE DETAIL
APPROVED FOR DISTRIBUTION <i>J. Daniel Davis</i>	TUBULAR SIGN STRUCTURES TUBULAR CANTILEVER SIGN SUPPORT DETAILS
ROUTE LOCATION	DRAWING NO. SD 9.10 (4of5)
TRACS NO.	OF