

Note to Designer:
 The information presented in this Standard Detail has been prepared in accordance with recognized engineering principles and is for general use. It should not be used for specific application without competent professional examination and verification of its suitability and applicability by a licensed professional engineer. Contents within the inner border line shall not be altered.

NO.	DESCRIPTION OF REVISIONS	DATE	MADE BY
1	Original Issue	9-01	6.U.H.
2	Drawing Number Change	8-02	6.U.H.
3	General Update	12-09	6.U.H.
4			

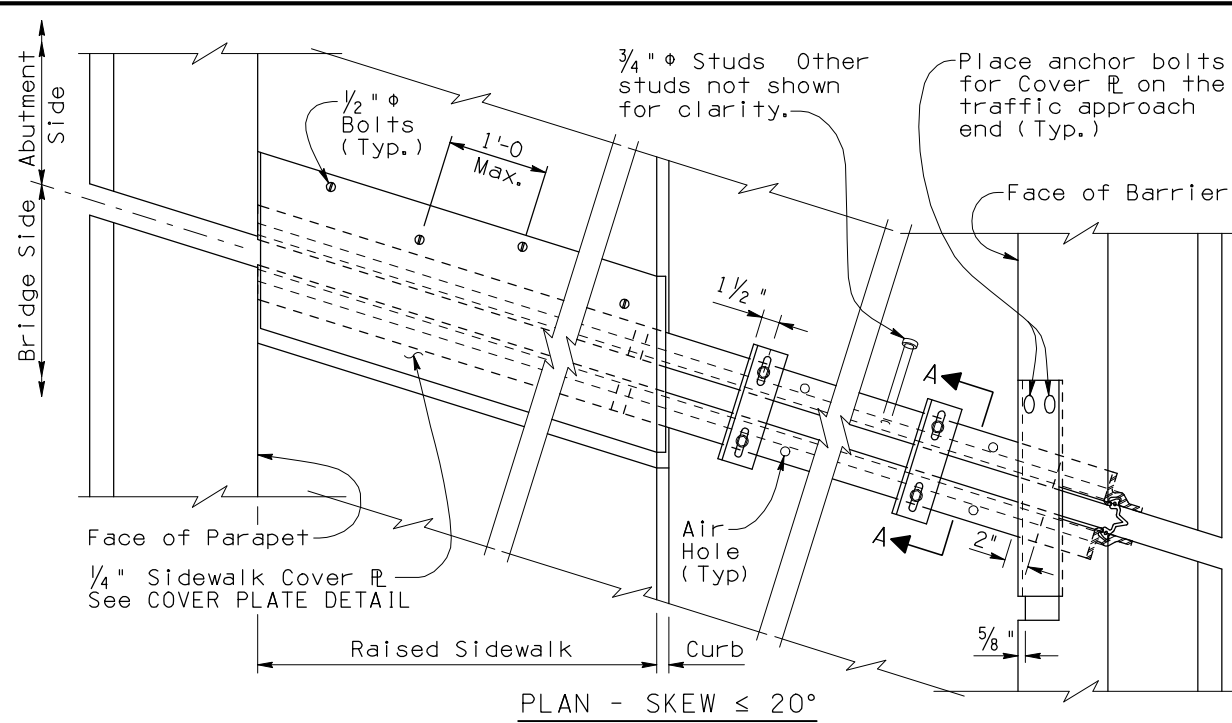

PLAN - SKEW $\leq 20^\circ$

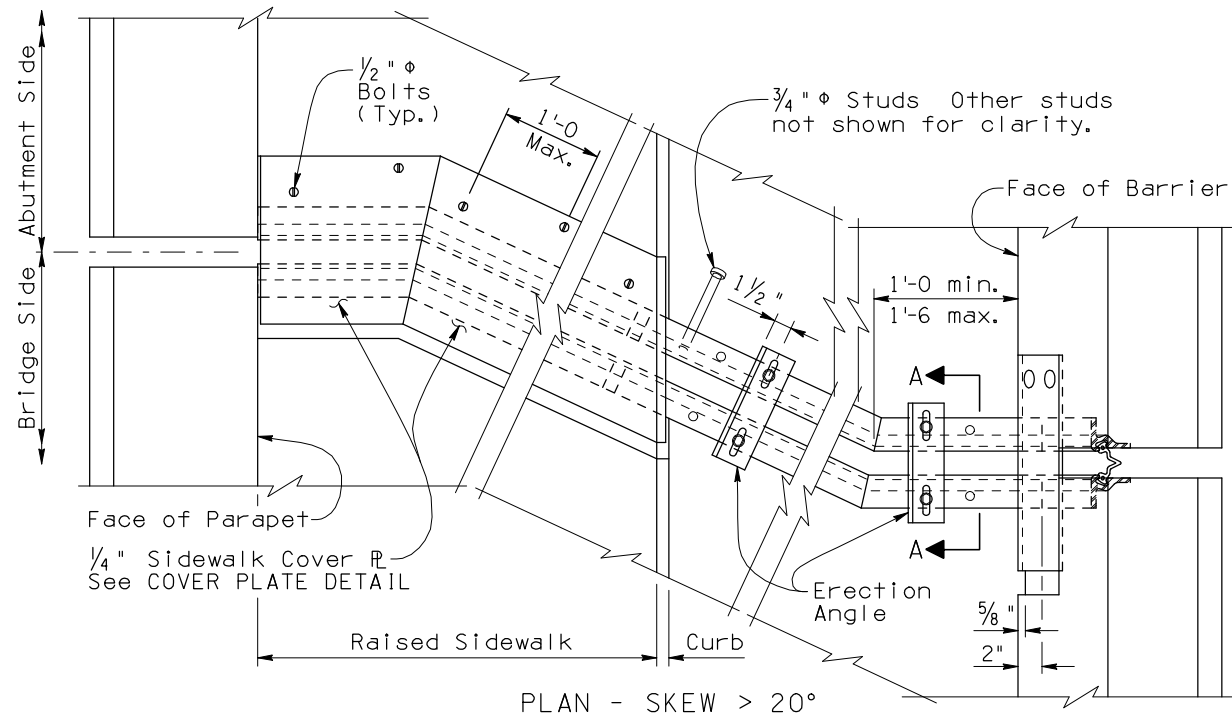

PLAN - SKEW $> 20^\circ$

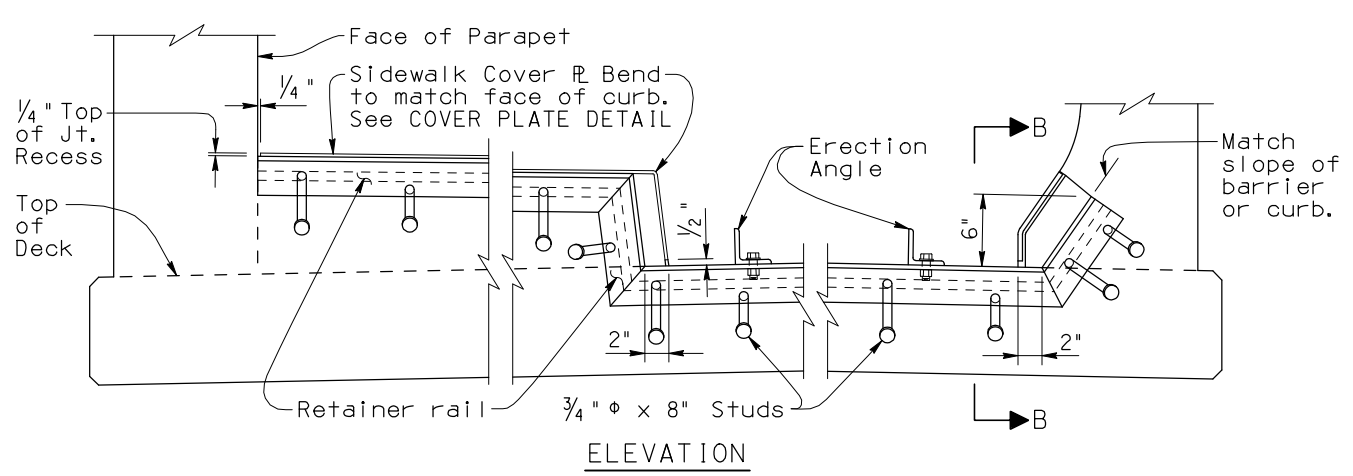

ELEVATION

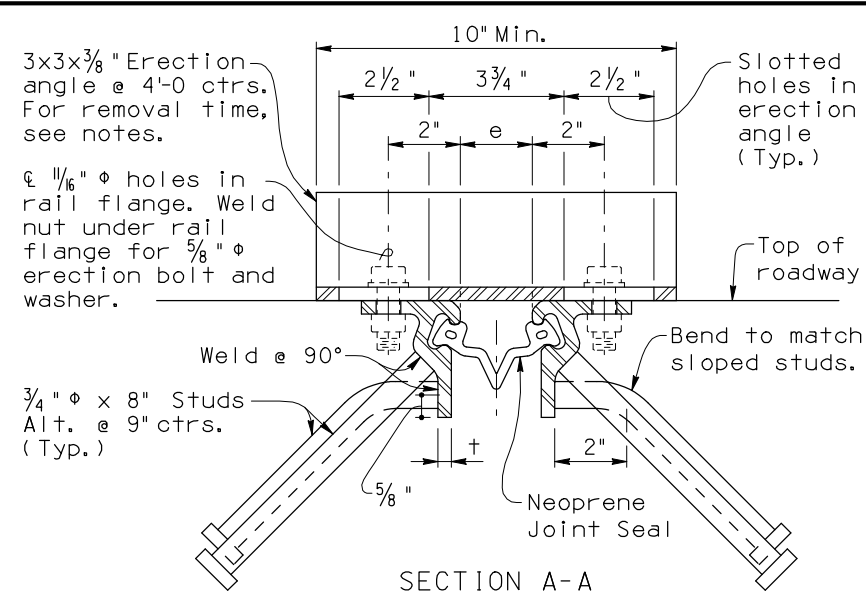

SECTION A-A

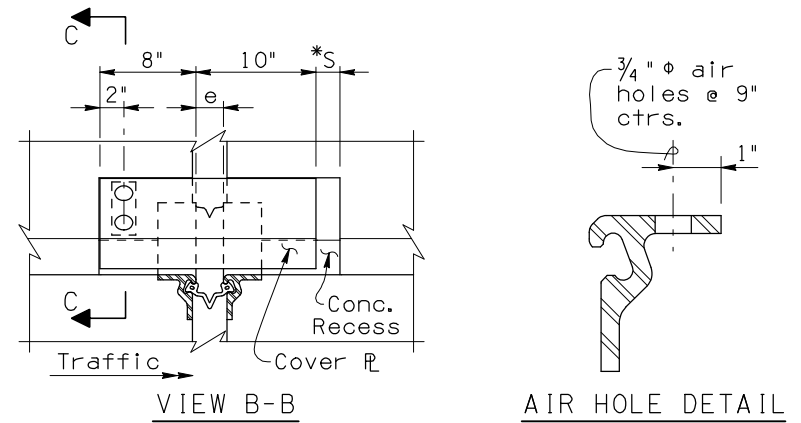

VIEW B-B

AIR HOLE DETAIL

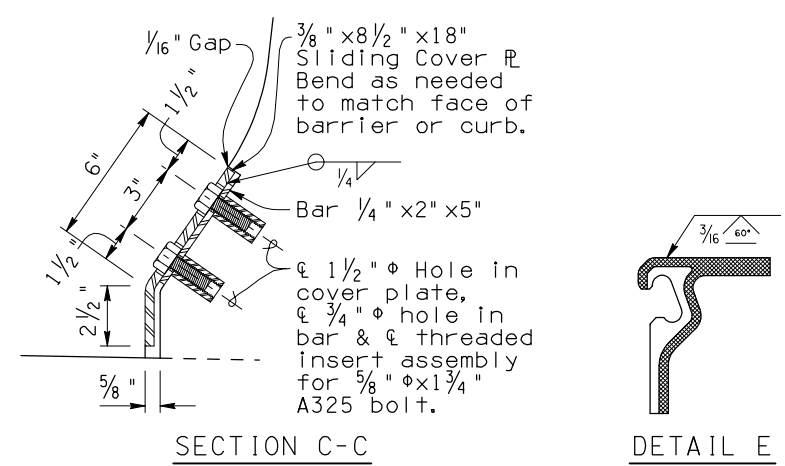

SECTION C-C

DETAIL E

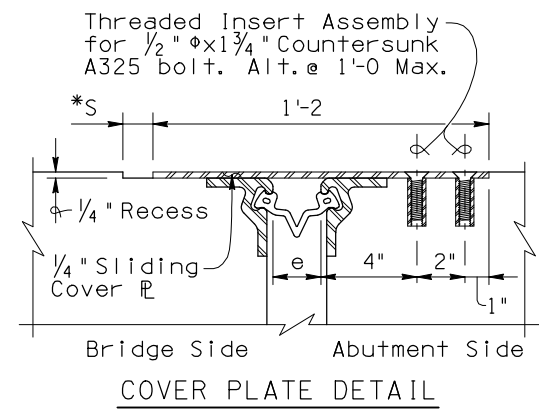

COVER PLATE DETAIL

GENERAL NOTES:

Construction Specification - Arizona Department of Transportation Standard Specifications for Road and Bridge Construction, latest Edition.

Design Specifications - AASHTO LRFD Bridge Design Specifications, 4th Edition 2007.

The Strip Seal Joint may only be used for movement ratings of 4 inches or less. Joint opening e and movement rating M.R. may require adjustment during shop drawing review to accommodate the manufacturer minimum seal installation width.

Retainer rail extrusions shall conform to ASTM A588 Grade 50 or A709 Grade 50W:
 Minimum weight per foot = 8.5 Lbs
 Minimum thickness, $t = 3/8$ inches
 Steel anchor studs shall conform to ASTM A108 Grades 1015, 1018 or 1020.

Retainer rails shall be one continuous full length installed piece. Retainer rails shall be supplied in maximum practical lengths that are consistent with normal manufactured rail length. Rail splices, when required, shall be welded in the shop or field per DETAIL E. Mitered rail turns shall be welded similar to DETAIL E.

The strip seal shall meet the requirements of ADOT Std. Spec. 1011-5. The strip seal shall be supplied in one continuous full length piece without splices.

Sidewalk cover plates shall be A36 galvanized steel with non-slip (deformed) surface. Barrier or curb cover plates shall be A36 galvanized steel. All cover plate bolts shall be A325 galvanized.

All welding shall conform to the requirements of the American Welding Society, ANSI/AASHTO/AWS D1.5 Bridge Welding Code, latest Edition.

Prior to installation of the seal and lubricant adhesive, steel contact surfaces with the seal shall be cleaned and prepared in accordance with the seal manufacturer requirements.

Joint opening e shall be adjusted in the field for any variation of temperature above or below the mean temperature. See bridge drawings for mean temperature, e and temperature correction chart.

Erection angles shall be removed immediately after deck joint is fully encased in concrete (except sidewalks, curbs or barriers), and such concrete has attained its initial set (2 hours \pm).

Dimensions shall not be scaled from drawings.

Item No. 6011345 Deck Joint Assembly (Strip Seal)
 Measurement: Linear Foot

$*S = M.R. / 2 (1/2 \text{ inch min.})$

DESIGN APPROVED <i>Shafiq U. Hasan</i>		ARIZONA DEPARTMENT OF TRANSPORTATION INTERMODAL TRANSPORTATION DIVISION BRIDGE GROUP STRUCTURE DETAIL	
APPROVED FOR DISTRIBUTION <i>Tean A. Nehme</i>		DECK JOINT ASSEMBLY STRIP SEAL	
ROUTE	PROJECT NO.	FA NO.	DRAWING NO. SD 3.02
LOCATION			SHEET NO. OF