

NO	DESCRIPTION OF REVISIONS	MADE BY	DATE
1	RE-ISSUE	L. LOPEZ	2/02
2	ADDED CALL OUT TO "REAR ELEVATION", REVISED NOTE	L. LOPEZ	6/06
3			
4			

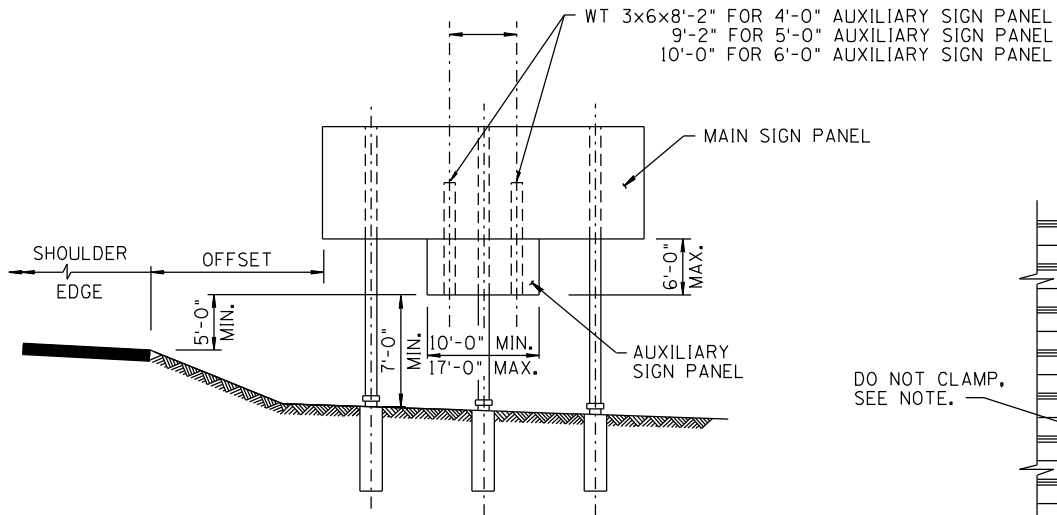

**THREE POSTS SIGN & TWO POST SIGN**  
WITH SPACING GREATER THAN WIDTH  
OF AUXILIARY SIGNS MINUS 1'-0"

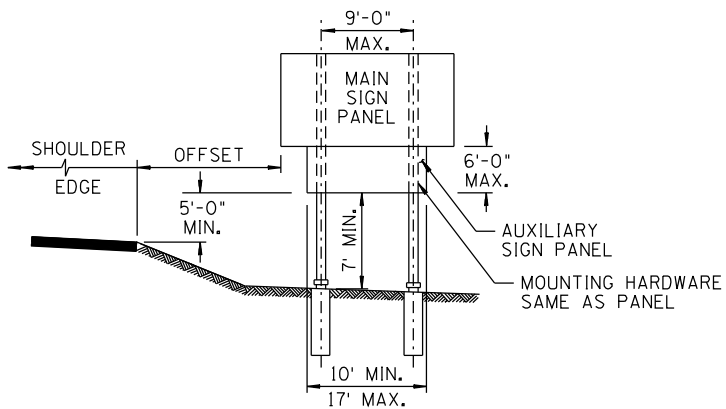

**TWO POSTS SIGN**  
POST SPACING LESS THAN WIDTH OF  
AUXILIARY SIGNS MINUS 1'-0"

WT 3x6 SHALL BE A.S.T.M. A36/A36M-00 STEEL GALVANIZED TO CONFORM TO THE REQUIREMENTS OF A.S.T.M. A123/A123M-97a(1999)e1

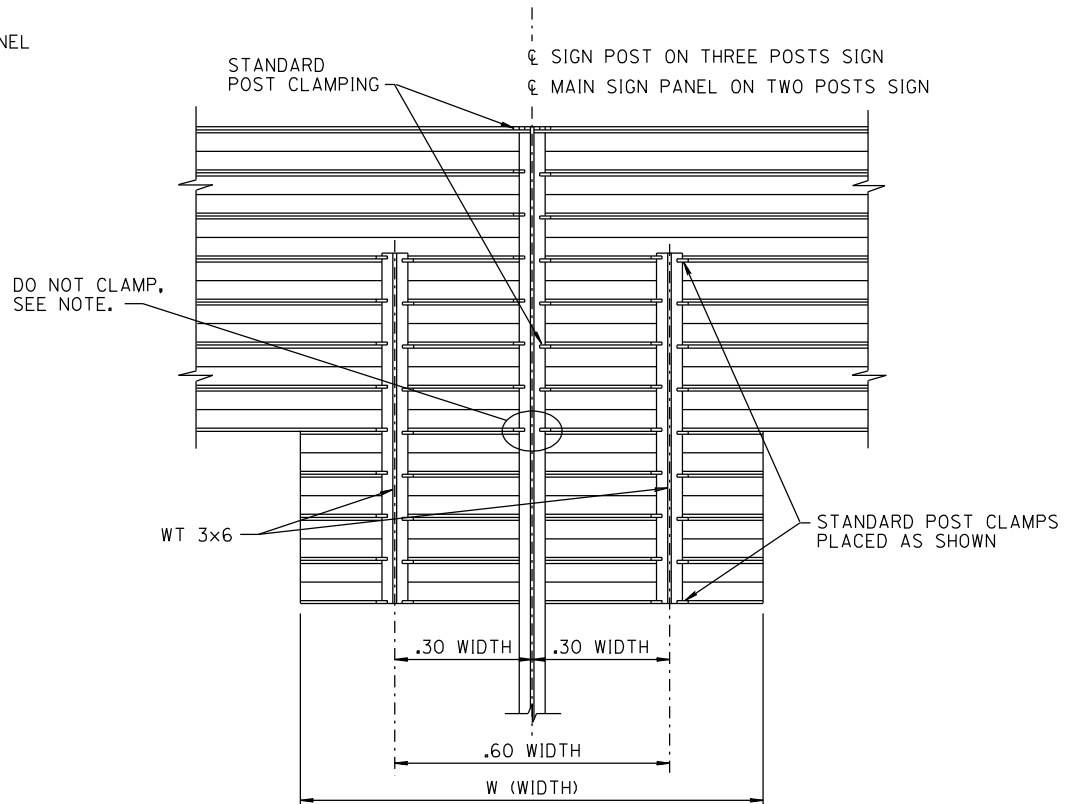

**REAR ELEVATION**

**NOTE:**

DO NOT CLAMP AUXILIARY SIGN TO THE MIDDLE POST ON THREE POST SIGNS.

NOT TO SCALE

DESIGN APPROVED  L. LOPEZ DISTRICT ENGINEER	ARIZONA DEPARTMENT OF TRANSPORTATION INTERMODAL TRANSPORTATION DIVISION STANDARD DRAWINGS	REV. 6/06
	AUXILIARY SIGN INSTALLATION DETAILS	DRAWING NO. S-7